

787-01-0001 MINI BRUSH CUTTER

PARTS BREAKDOWN

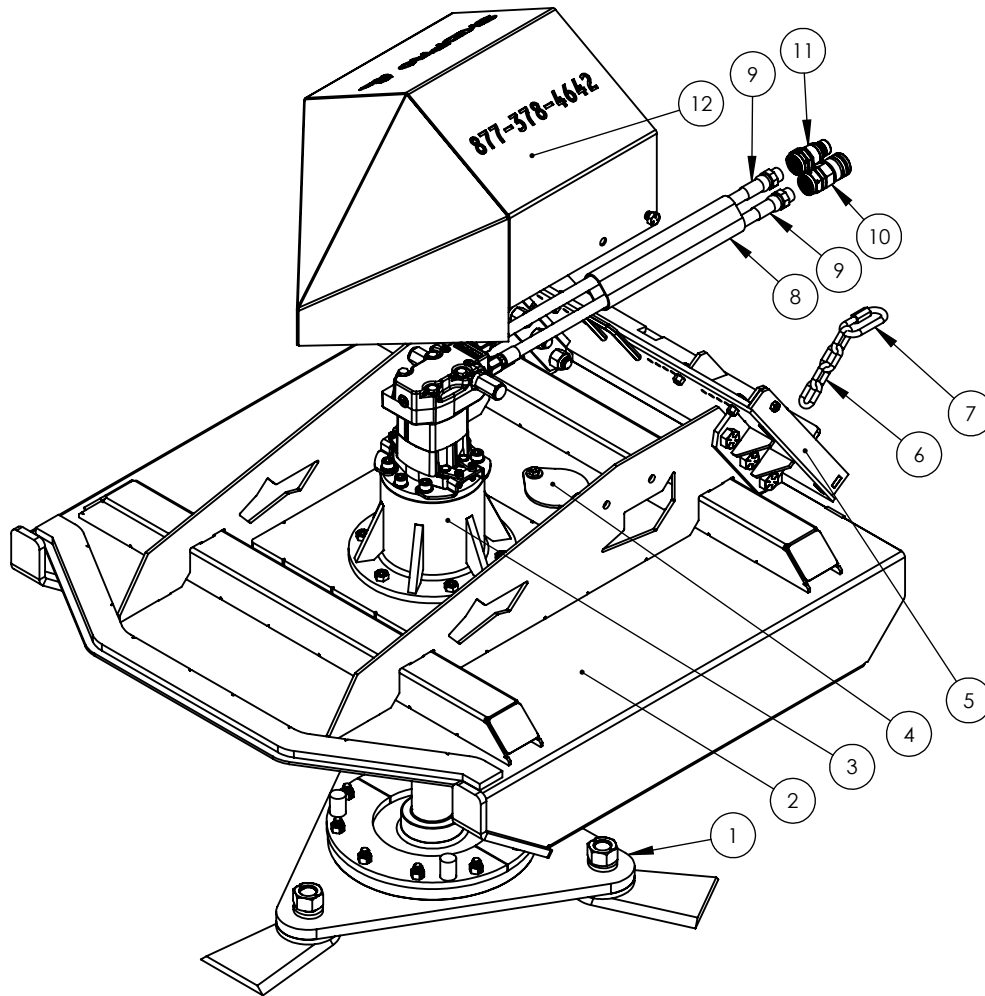

ITEM NO.	PART NUMBER	DESCRIPTION	QTY.
1	787-02-0002-36	36" FLYWHEEL ASM	1
*1	787-02-0002-48	48" FLYWHEEL ASM	-
2	787-02-0001-36	MOWER BODY ASM - 36"	1
*2	787-02-0001-48	MOWER BODY ASM - 48"	-
3	DRIVE ASSEMBLY	DIRECT DRIVE MOTOR	1
4	612-3-0025	INSPECTION COVER	1
5	787-02-0009-ASM	CII-COMMON IND INTERFACE ASM	1
*5	787-02-0010-ASM	MQT-BOBCAT STYLE QT ASM	-
6	612-3-0046	SAFETY CHAIN	1
7	612-3-0128	3/8 QUICK LINK	1
8	HSL500	HOSE SLEEVE	6FT
9	787-03-0037	1/2" X 72" HOSE 10 FJIC 12 MORB	2
*9	787-03-0038	1/2" X 78" HOSE 10 FJIC 12 MORB	-
10	AU-03-9990-12-12	1/2" FEMALE COUPLER	1
11	AU-03-9991-12-12	1/2" MALE COUPLER	1
12	787-02-0006	MINI HOOD - ASM	1

*DENOTES ALTERNATE OPTION (NOT PICTURED)

787-02-0002-48

48" FLYWHEEL ASM - PARTS BREAKDOWN

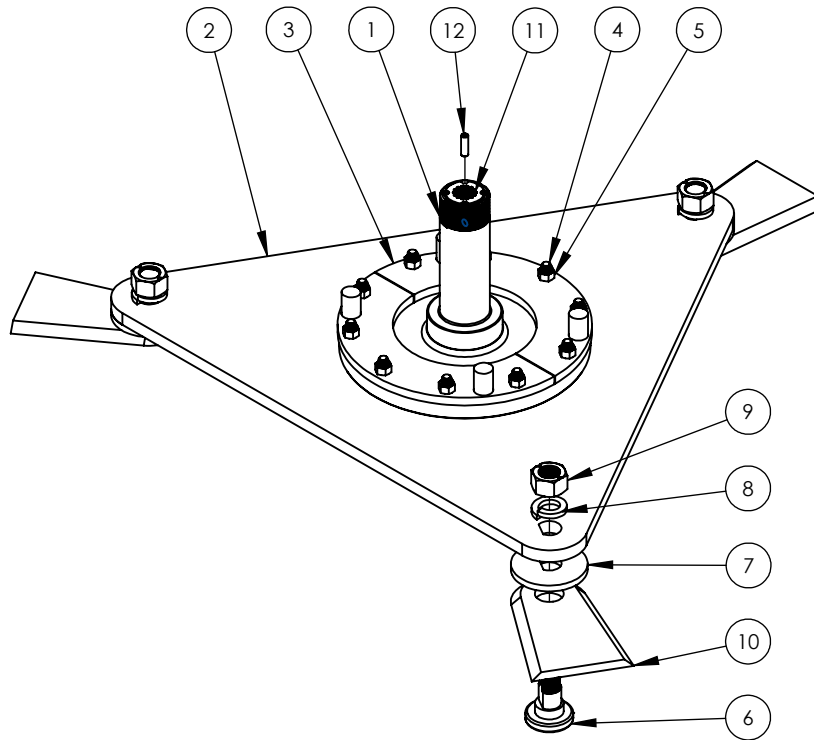

ITEM NO.	PART NUMBER	DESCRIPTION	QTY.
1	612-2-0010	MOWER SPINDLE	1
2	787-03-0021-48	48" FLYWHEEL	1
3	612-2-0007	WIRE PROTECTION, LOWER	2
4	HW-.500-13X3G8TB	1/2" -13 X 3" GRADE 8 TAP BOLT	10
5	HW-.500-13RLN	1/2"-13 REVERSE LOCK NUT	10
6	612-3-0048	BLADE BOLT	3
7	787-03-0020	.375 BLADE BOLT SPACER	3
8	HW-1.125 LW	1 1/8" LOCK WASHER	3
9	HW-1.125-12 TLHN	1 1/8" -12 INTERNAL LOCKING NUT	3
10	787-03-0019	MINI BRUSH CUTTER BLADE	3
11	612-3-0059	SHAFT HUB GEN 1 MOWER	1
12	612-3-0097	DOWEL 3/8" X 1-1/4" - PULL OUT	4

787-02-0002-36

36" FLYWHEEL ASM - PARTS BREAKDOWN

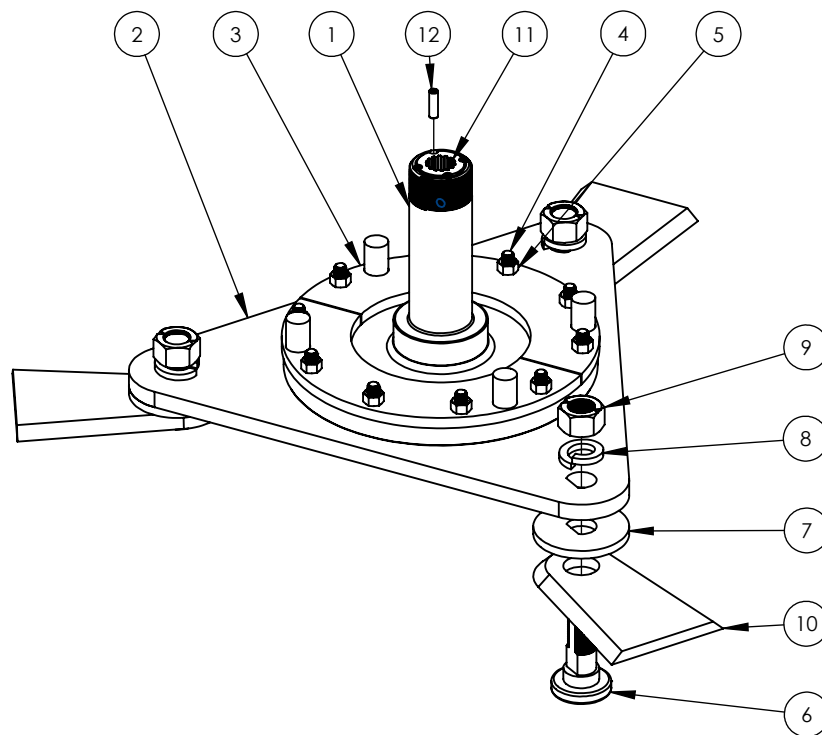

ITEM NO.	PART NUMBER	DESCRIPTION	QTY.
1	612-2-0010	MOWER SPINDLE	1
2	787-03-0021-36	36" FLYWHEEL	1
3	612-2-0007	WIRE PROTECTION, LOWER	2
4	HW-.500-13X3G8TB	1/2" -13 X 3" GRADE 8 TAP BOLT	10
5	HW-.500-13RLN	1/2"-13 REVERSE LOCK NUT	10
6	612-3-0048	BLADE BOLT	3
7	787-03-0020	.375 BLADE BOLT SPACER	3
8	HW-1.125 LW	1 1/8" LOCK WASHER	3
9	HW-1.125-12 TLHN	1 1/8" -12 INTERNAL LOCKING NUT	3
10	787-03-0019	MINI BRUSH CUTTER BLADE	3
11	612-3-0059	SHAFT HUB GEN 1 MOWER	1
12	612-3-0097	DOWEL 3/8" X 1-1/4" - PULL OUT	4

787-01-0001 DRIVE ASSEMBLY

PARTS BREAKDOWN

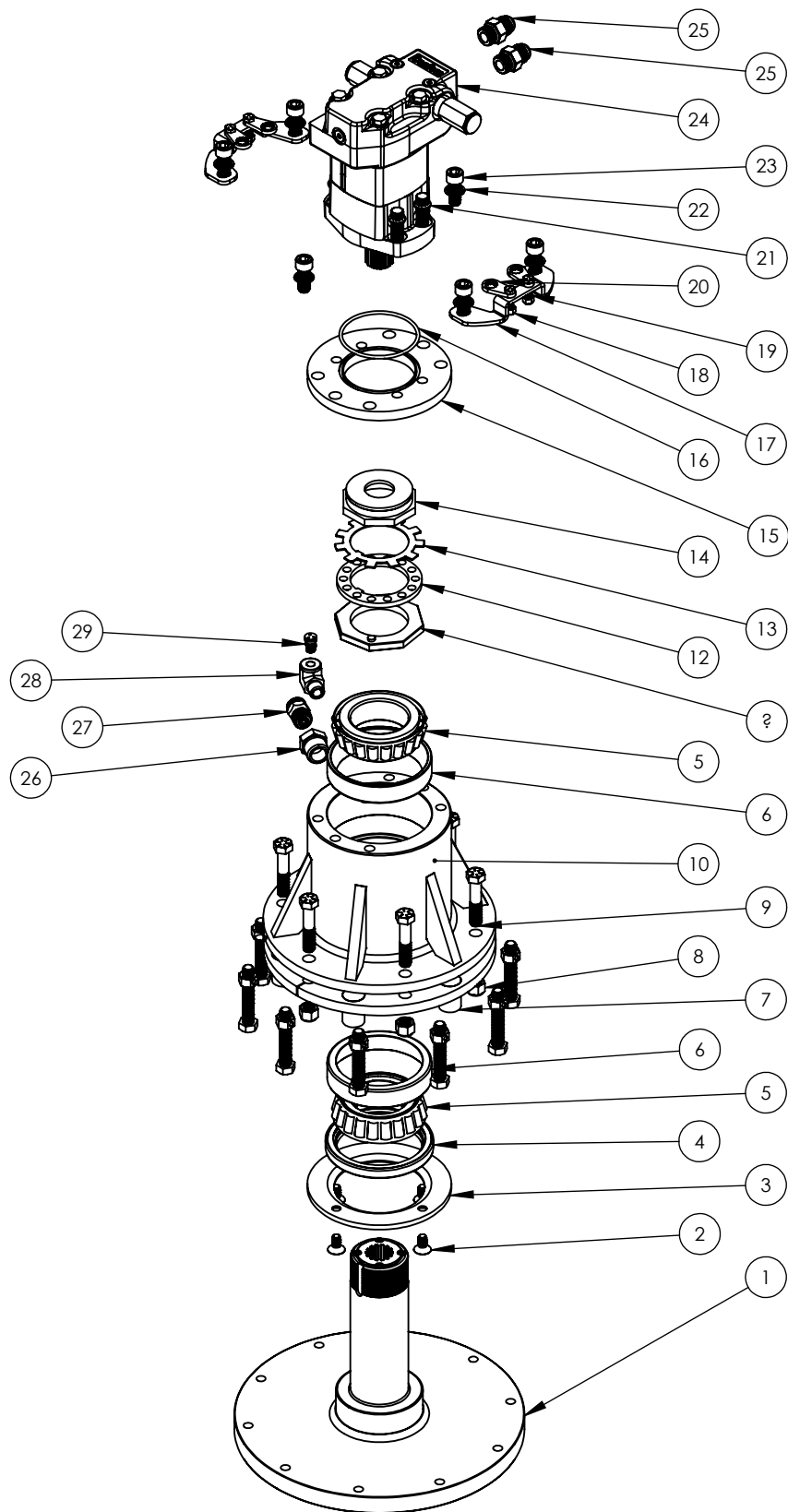

787-01-0001 DRIVE ASSEMBLY

PARTS BREAKDOWN

ITEM NO.	PART NUMBER	DESCRIPTION	QTY.
1	612-2-0010	MOWER SPINDLE	1
2	HW-.375-16X.75FS	3/8"-16 X 3/4" FLAT HEAD CAP SCREW	4
3	612-3-0063	SEAL PROTECTION	1
4	612-3-0058	SEAL	1
5	612-3-0054	BEARING, CONE	2
6	612-3-0053	BEARING RACE	2
7	612-2-0008	WIRE PROTECTION, UPPER	2
8	HW-.500-20NYLG8	1/2"-20 NYLOCK NUT G8	6
9	HW-.500-20X2.5G8	1/2"-20 X 2.5 HH G8	6
10	612-2-0009	BEARING HOUSING	1
11	612-3-0096	HEX NUT 2-5/8"	1
12	612-3-0050	SHAFT LOCK WASHER	1
13	612-3-0051	TAB WASHER 2-5/8"	1
14	612-2-0021	SHAFT NUT WLD ASM	1
15	612-3-0026	MOTOR MOUNTING PLATE (GEN 1)	1
16	612-3-0132	ORING (STANDARD FLOW MOTOR)	1
17	787-03-0032	GEN 1 BOLT RETAINER BRACKET	2
18	HW-.25-20NYL	1/4"-20 NYLOCK NUT	4
19	HW-.25-20X1.0G5	1/4"-20X1" GRADE 5 BOLT	4
20	612-3-0210	BOLT RETAINER TAB	4
21	HW-.500-20X1.5FCS	1/2"-20 X 1 1/2" FERRY CAP SCREW	4
22	HW-.500INTLW	1/2" INTERNAL LOCK WASHER	6
23	HW-.500-20X1.25CS	1/2"-20 X 1 1/4" SOCKET HEAD CAP SCREW	6
24	787-03-0040	4.9 CU/IN RELIEF MOTOR	1
25	H750-6400-10-10	ADAPTER -10 MORB X -10MJIC	2
26	H750-5406-12-08	3/4 MNPT X 1/2 FNPT BUSHING	1
27	H500-H1820	HD BUTTON HEAD GREASE FITTING	1
28	H375-5502-06-02	3/8 MNPT X 1/8 FNPT 90 DEG	1
29	H125-A321620	1/8 NPT STRAIGHT BREATHER	1

787-02-0010-ASM
MQT-BOBCAT STYLE QT ASM

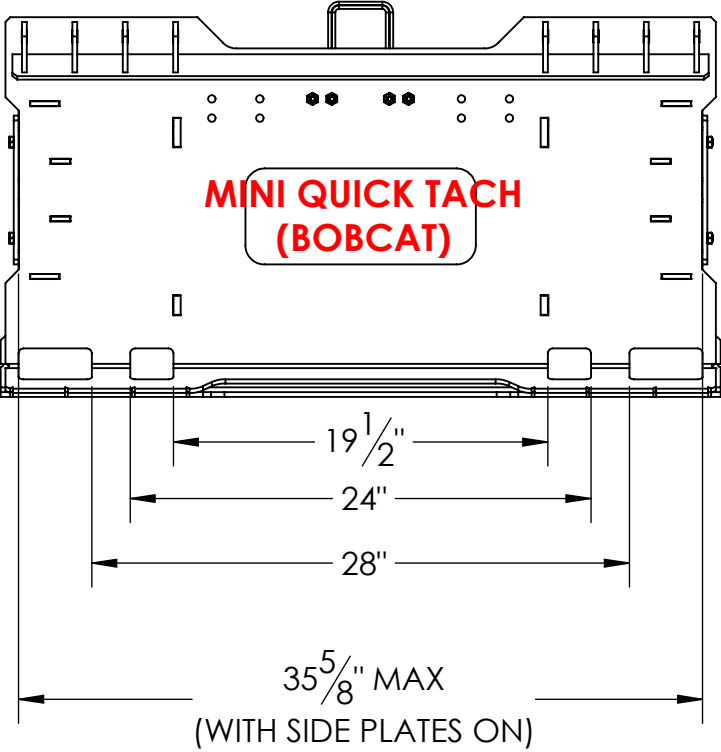
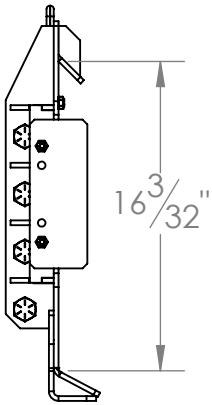
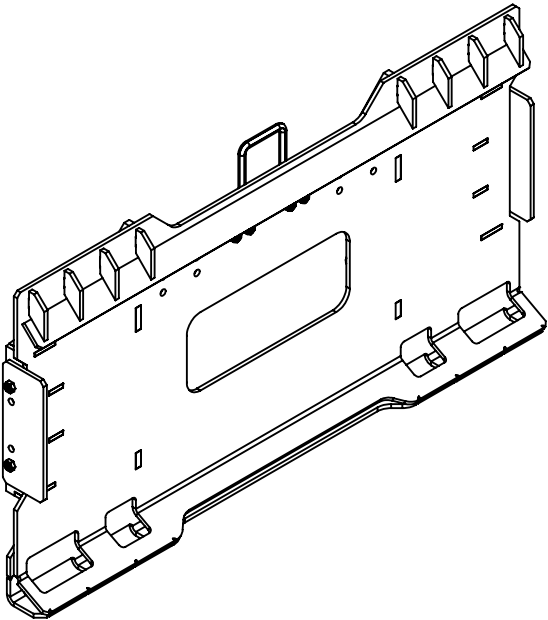

787-02-0010-ASM

PARTS BREAKDOWN

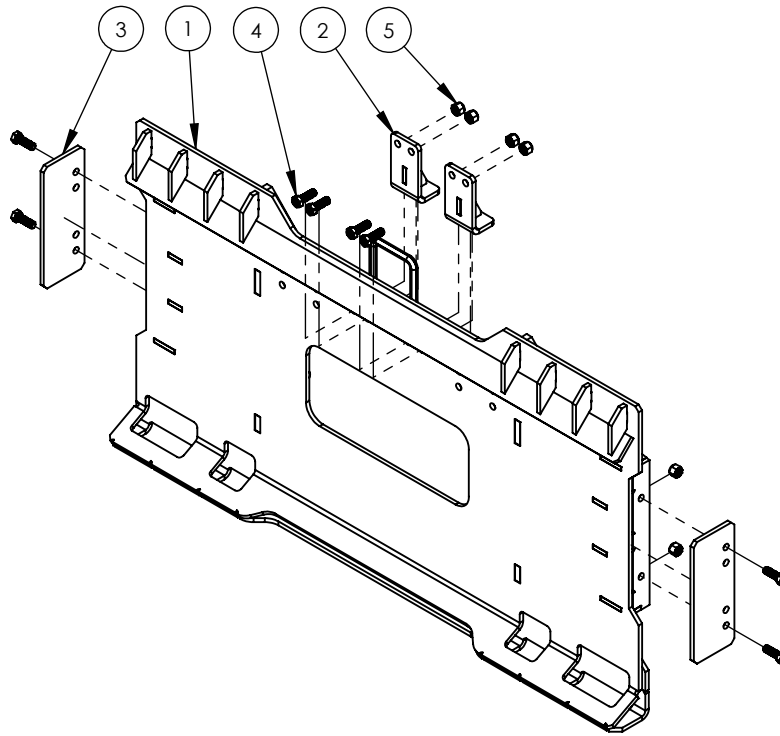

ITEM NO.	PART NUMBER	DESCRIPTION	QTY.
1	787-02-0004	MQT - BOLT ON	1
2	787-02-0007	MQT - LOCATING BRACKET	2
3	787-03-0035	MQT - BOLT ON SIDE	2
4	HW-.375-16X1.125G8	3/8"-16X1-1/8" GRADE 8	8
5	HW-.375-16NYLG8	3/8"-16 NYLOCK GRADE 8	8
6	HW-.750-10X2.0G8	3/4"-10 X 2" HH G8	8
7	HW-.750-10NYLG8	3/4"-10 NYLOCK NUT G8	8

REMOVE SIDE PLATES AND LOCATE INSIDE
WHEN MOUNTING ON FULL SIZE QT

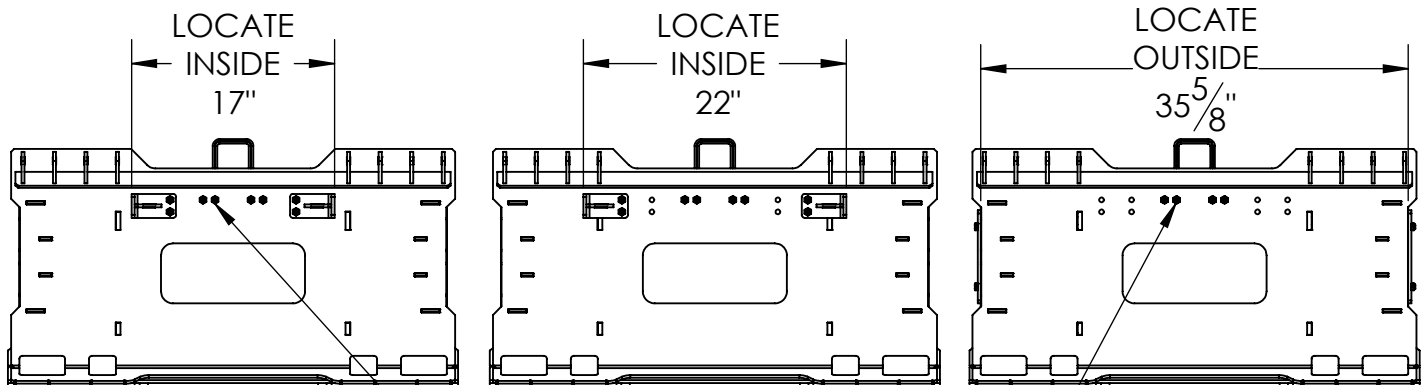

USE CENTER HOLES TO
STORE UNUSED HARDWARE

787-02-0009-ASM
CII-COMMON IND INTERFACE ASM

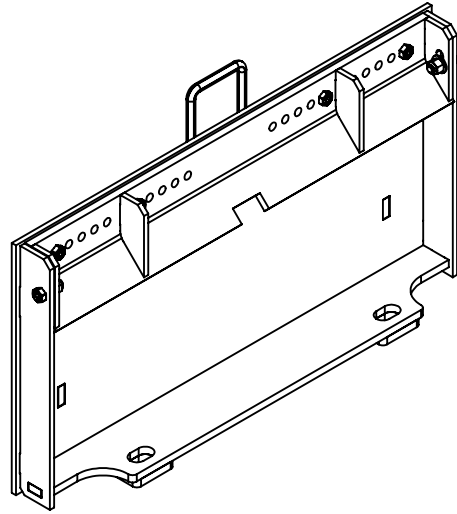

ADJUSTABLE IN 1/8" INCREMENTS
SHIPS STANDARD AT 9-1/2"
MAX = 9-1/2" (OUTSIDE HOLES)
MIN = 9" (INSIDE HOLES)

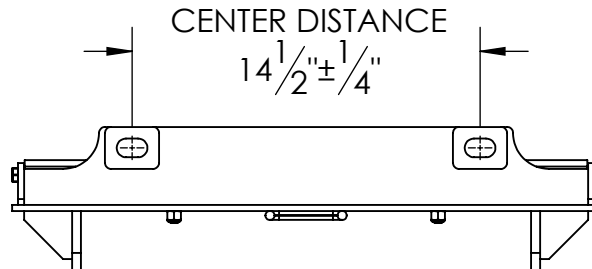
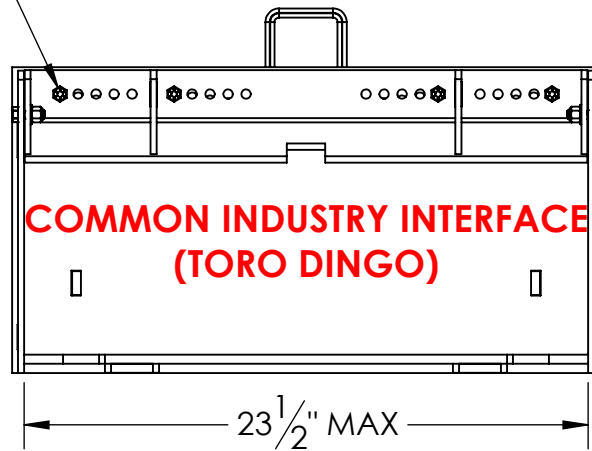
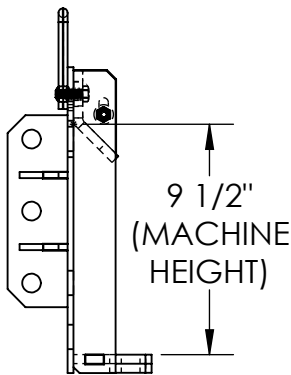

787-02-0009-ASM
PARTS BREAKDOWN

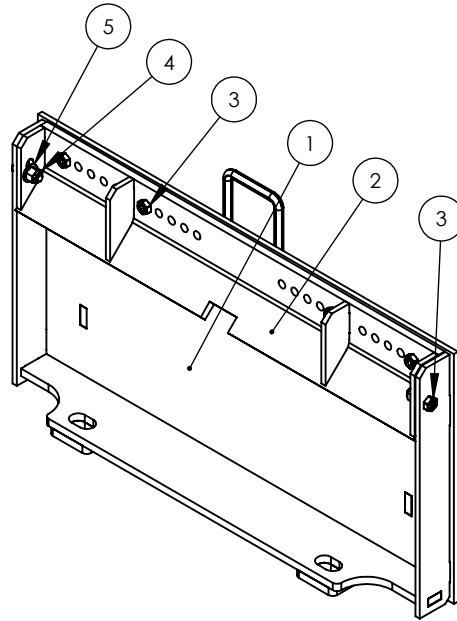

ITEM NO.	PART NUMBER	DESCRIPTION	QTY.
1	787-02-0003	CII QT - BOLT ON	1
2	787-02-0008	CII QT - BOLT ON TOP BAR	1
3	HW-.375-16X1.125G8	3/8"-16X1-1/8" GRADE 8	6
4	HW-.375-16NYLG8	3/8"-16 NYLOCK GRADE 8	6
5	HW-.375 SAE FW G8	3/8" SAE WASHER G8	2
6	HW-.750-10X2.0G8	3/4"-10 X 2" HH G8	6
7	HW-.750-10NYLG8	3/4"-10 NYLOCK NUT G8	6

787-01-0001 MINI BRUSH CUTTER

REPLACEMENT DECALS

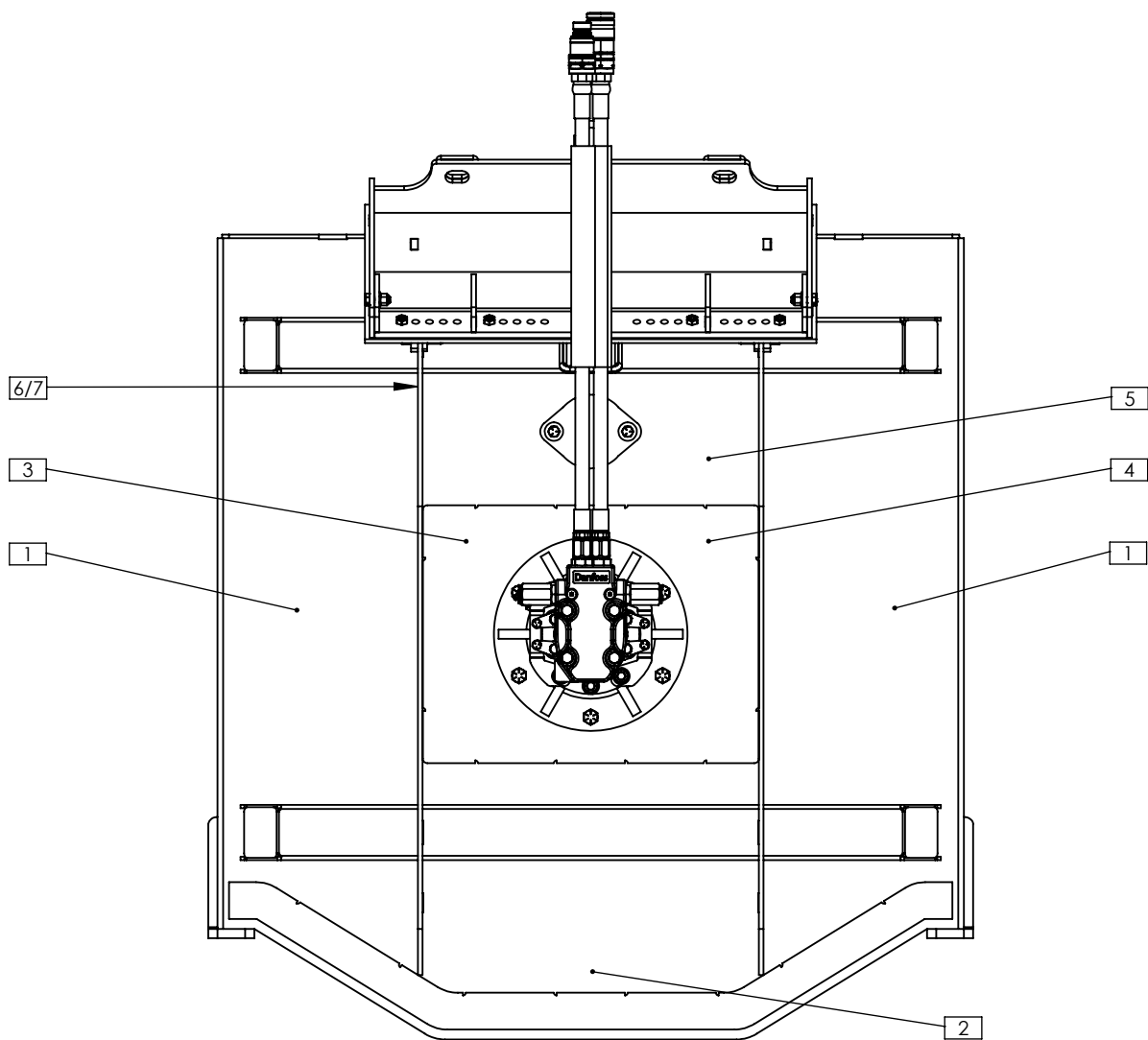

ITEM NO.	PART NUMBER	DESCRIPTION	QTY.
1	DECAL-3-0004	3X10 "WARNING"	2
2	DECAL-3-0006	2.250X10 "DANGER"	1
3	DECAL-3-0008	3X5 "HIGH PRESSURE FLUID"	1
4	DECAL-3-0009	3X3 "READ OWNERS MANUAL"	1
5	DECAL-3-0010	5X5 "DO NOT OPERATE WITHOUT SA"	1
6	DECAL-3-0170	787-01-0001 serial#	1
7	DECAL-3-0172	36" WIDTH DECAL, SILVER LETTER	1
*7	DECAL-3-0171	48" WIDTH DECAL, SILVER LETTER	-