



Trencher

Operation and Maintenance Manual



INDEX

FOREWORD	4
Enquiries	4
Operating Limits	4
The Machinery Directive (European Community only)	4
Declaration Of Conformity	4
REGISTRATION	6
INTRODUCTION	9
SAFETY NOTES	10
Protect Yourself	10
You May Need	10
Know Your Equipment	10
Danger, Warning And Caution	10
Protective And Safety Devices	11
Check The Equipment	11
Hazard Classification (Only applicable to ANSI Safety Labels)	11
Safety Precautions	12
IDENTIFICATION	13
Typical Setup	13
FITTING THE TRENCHER UNIT	14
Excavators - Double Pin Hitch	14
Excavators - Quick Hitch	15
Skid Steer Loaders	16
HYDRAULIC CONNECTIONS	17
RUNNING-IN	18
PREPARATION	19
TRENCH DEPTH SETTING	20
SKID SIDE PLATE ADJUSTMENT	21
WORKING PROCEDURE	22
TRANSPORTATION	24
Transportation On Public Highways	24
Transportation Within The Job Site	24
Recommended Travel Position	24

MAINTENANCE & LUBRICATION	25
Routine Maintenance	26
Daily Checks	26
Weekly Checks (in addition to daily checks)	26
Oil capacity	26
Oil Change Procedure	27
Chain Adjustment	28
Chain Removal/Replacement	29
Cutting Tooth Maintenance	30
Nose Roller Bearing Replacement	31
Sprocket Removal & Replacement - MT/MTDD Trencher	32
Sprocket Removal & Replacement - XHD Trencher	33
TROUBLESHOOTING	34
WARRANTY STATEMENT	36

FOREWORD

Enquiries

Please state the model type and serial number when making enquiries or orders and all written correspondence. The serial number is recorded on a plate located on the side of the Trencher.

Operating Limits

Model:	Serial No:	Weight:
<input type="text"/>	<input type="text"/>	<input type="text"/>
Flow Range:	From <input type="text"/> To <input type="text"/>	CE 
Pressure Range:	From <input type="text"/> To <input type="text"/>	
Max. Back Pressure:	<input type="text"/>	Date of Manufacture <input type="text"/> <input type="radio"/>

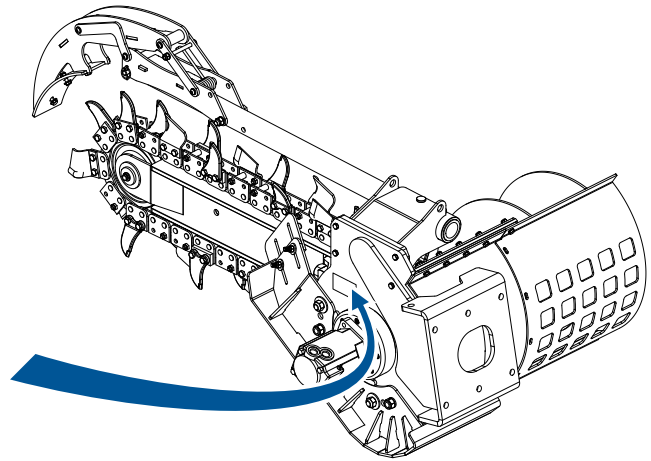

This equipment must be operated within the parameters stated on the serial plate. Failure to do so may cause damage to the equipment and invalidate the warranty. If in doubt, contact Skid Pro Attachments.

REGISTRATION

Complete this form and keep it with the manual



MODEL NUMBER:

SERIAL NUMBER:

DATE OF MANUFACTURE:

SUPPLIER / DEALER:

DATE SOLD TO SUPPLIER / DEALER:

DATE SOLD TO ORIGINAL END USER:

OWNER OR OPERATOR:

PARENT MACHINE MAKE & MODEL:

Note; Always quote the serial number in any communication with your supplier / dealer

INTRODUCTION

Skid Pro Attachments thank you for purchasing your new product. This operating manual has been prepared to enable you to operate the equipment in a safe manner.

Skid Pro Attachments have been designed for use with specific parent machines along with the Skid Pro Attachments range of mounting frames. Provided these are used and maintained correctly, they will provide a safe and reliable method of trenching in the earth.

For information on lubrication and maintenance intervals, see page 26

Before operating the drive unit, please note:

Your drive unit comes complete, filled with the correct amount of oil. There is no need to check the oil level.

Hydraulic hoses must be fitted and tightened to the correct torque (see page 17).

The unit must be run in following the recommended procedure (see page 18).

NOTE:

This operating manual should be used in conjunction with the parent machine's operating instructions.

Instruction books should be regarded as part of the machine. They should always be kept safe with the machine for easy and quick reference.

New or extra copies can be obtained from Skid Pro Attachments.

Skid Pro Attachments continually strives to improve and increase its range of products and therefore reserves the right to alter its specifications at any time without notice or obligation. The company accepts no responsibility for discrepancies, which occur between specifications of its machines and descriptions thereof contained in its publications.

SAFETY NOTES

Protect Yourself

Make sure you wear protective clothing and personal safety items.

You May Need

- A Hard Hat
- Safety Goggles
- Hearing Protection
- Foul Weather Clothing
- Reflective Clothing
- Protective Gloves
- Safety Boots

DO NOT wear items of loose clothing, jewellery or other items and tie up any long hair which could entangle in the controls or other parts of the machine.

Know Your Equipment

Get to know all you how to operate all controls on the machine and the attachments

IF THERE IS SOMETHING IN THE MANUAL WHICH YOU DO NOT UNDERSTAND, CONTACT THE MACHINE AGENT OR MANUFACTURER AND ASK THEM TO EXPLAIN IT TO YOU.

Danger, Warning And Caution

This symbol below has 3 important meanings when used with the following captions.



DANGER: An IMMEDIATELY HAZARDOUS situation that WILL result in DEATH or VERY SERIOUS INJURY



WARNING: A POTENTIALLY HAZARDOUS situation that COULD result in DEATH or VERY SERIOUS INJURY



CAUTION: A POTENTIALLY HAZARDOUS situation that MAY result in MINOR INJURY

Protective And Safety Devices

Keep all protective devices in place and securely fastened. Make sure all guards, shields and safety signs are properly installed and are in good condition.

Check The Equipment

Before you operate the equipment, take time to check your machine and ensure that all systems are in good operational order.

- Never operate the equipment with worn, damaged or missing parts. Use only genuine replacement parts.
- Always ensure that the parent machine is secure and stable with its engine switched off and hydraulic pipes disconnected before carrying out any maintenance work.
- Check for loose, broken, missing or damaged parts. Have everything put into good repair and make sure all safety devices are in place.
- Perform all maintenance procedures outlined for the equipment.
- Always protect hands. Select appropriate gloves when handling the equipment during fitting, removing or adjusting
- Always protect feet with safety boots.



WARNING: Hydraulic fluid under pressure can penetrate the skin or eyes and cause serious PERSONAL INJURY, BLINDNESS OR DEATH.
Fluid leaks under pressure may not be visible. Use a piece of wood or thick cardboard to find leaks. DO NOT USE YOUR BARE HANDS.
Wear safety goggles for eye protection.
If any fluid is injected into the skin, it MUST be surgically removed.
SEE A DOCTOR IMMEDIATELY

Make sure all hydraulic lines are correctly installed

Before applying pressure to the hydraulic system be sure all connections are tight and that lines, pipes and hoses are not damaged. Before disconnecting hydraulic lines, be sure to relieve all pressure.

Hazard Classification (Only applicable to ANSI Safety Labels)



DANGER: IMMEDIATE HAZARD! - Failure to understand or obey this information is likely to result in personal injury or death.



WARNING: Failure to follow these instructions may result in personal injury or death.



CAUTION: Failure to follow these instructions may result in minor personal injury or damage to the machine or the vehicle.



NOTICE: This is important information for the proper use of this equipment. Failure to comply may lead to premature equipment failure.

CLEAN OR REPLACE THE SAFETY LABELS IF THEY CANNOT BE CLEARLY READ OR UNDERSTOOD

Safety Precautions

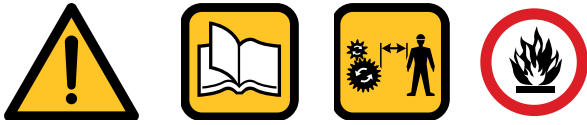

NEVER operate or assemble the equipment without **fully** understanding the operating instructions of both the equipment unit and the parent machine.

Skid Pro Attachments recommend you receive dealer instruction before operating the unit.

NEVER operate the equipment unless you are in good physical condition and mental health.

NEVER operate the equipment under the influence of any substance (including drugs & alcohol) which might impair vision.

NEVER operate the equipment with worn, damaged or missing parts. Use only genuine replacement parts.

NEVER proceed with works before completing a site risks assessment immediately before commencing work. Nominating the safe work exclusion zone radius for persons and animals as part of identifying risks and implementing controls.

NEVER allow minors to operate the equipment.



ALWAYS survey the work area before commencing operations. Check for potential hazards, eg. Electricity or communication cables etc.

ALWAYS ensure that the parent machine is secure and stable with it's engine switched off before carrying out any maintenance work.

ALWAYS ensure the hydraulic oil supply to the attachment is disconnected by uncoupling the hydraulic hose connectors before fitting, removing or adjusting the equipment

ALWAYS wear head protection and eye protection when working on the unit.

ALWAYS protect hands. Select appropriate when handling the equipment during fitting, removing or adjusting the unit.

ALWAYS protect feet. Wear approved safety boots.

ALWAYS follow the parent machine instructions regarding noise protection.

STAY ALERT. Should something break, come loose or fail to operate on your equipment, STOP WORK, lower equipment to the ground, shut off the engine and lock out hydraulic supply, inspect the machine and have repairs or adjustments made before resuming operation.

IDENTIFICATION

Typical Setup

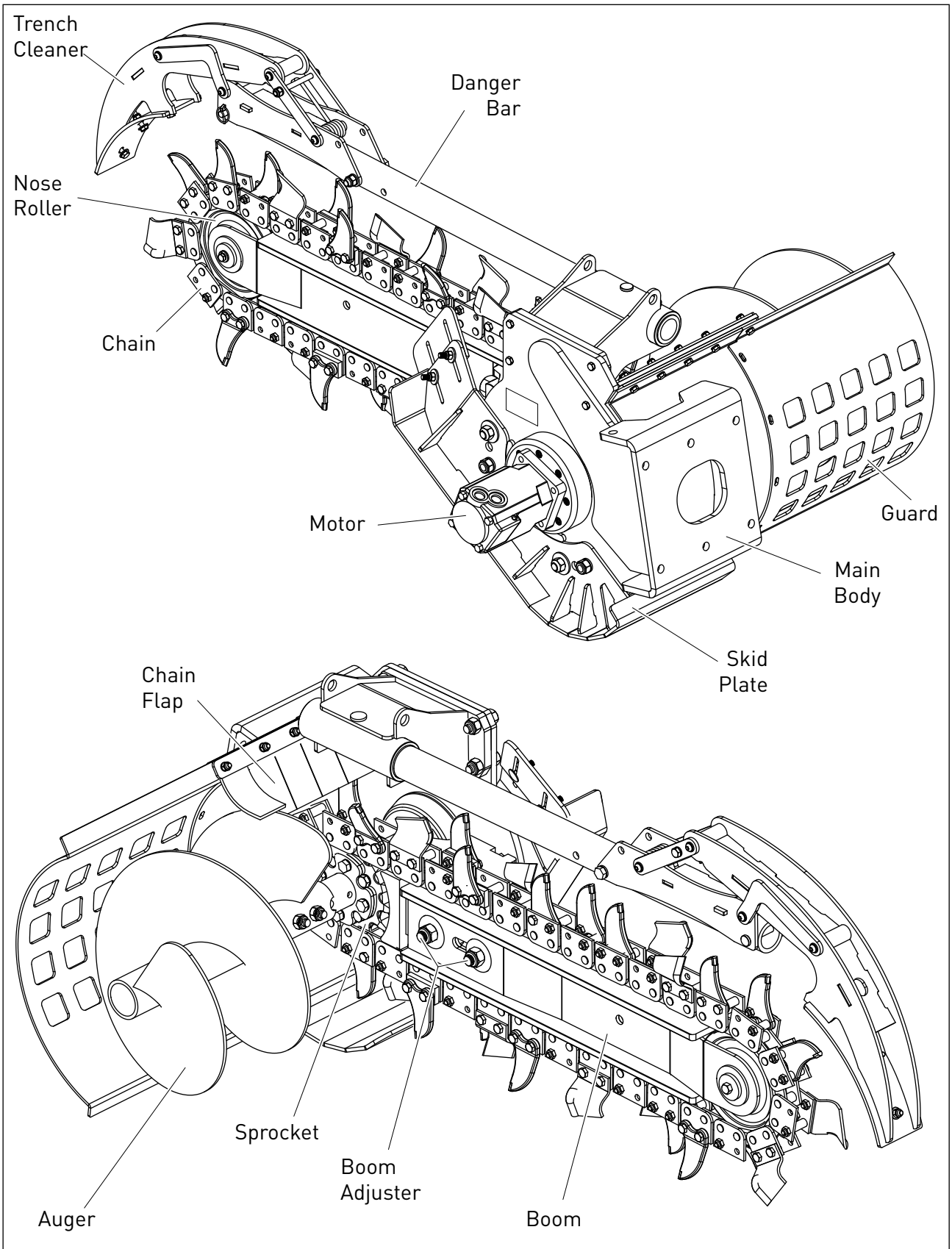

FITTING THE TRENCHER UNIT

Excavators - Double Pin Hitch

SAFETY FIRST



Always work in pairs (2 skilled operatives) whenever Trencher Unit components are being assembled or disassembled from the parent machine. Always check the weight of the attachment and ensure you have the correct equipment for handling it.



ALWAYS check parent machine:

- Is in correct working order
- Is parked correctly on flat ground
- Has its hand brake **ON**, its hydraulic circuit locked out and its engine switched **OFF**.

Check that the mounting frame is of the correct model and type to fit the parent machine. Ensure mounting frame and attachment points are clean before fitting. Use suitably rated lifting equipment if required (see data plate for weight).



FITTING Ensure all components are greased on assembly:

Refer to the parent machines operators manual for attaching accessories

- 1). Fit mounting frame to parent machine arms with the correct pins.
- 2). Align bolt location holes and fit location bolts and nyloc nuts.
- 3). Tighten all Nylon Insert nuts to 23 Nm / 17 ft-lb.

Locate the flow and return hydraulic pipes onto the Trencher Unit (see page 17).

Connect quick release couplers.

Check that the hydraulic pipes are of sufficient length to allow the trencher to articulate during work.

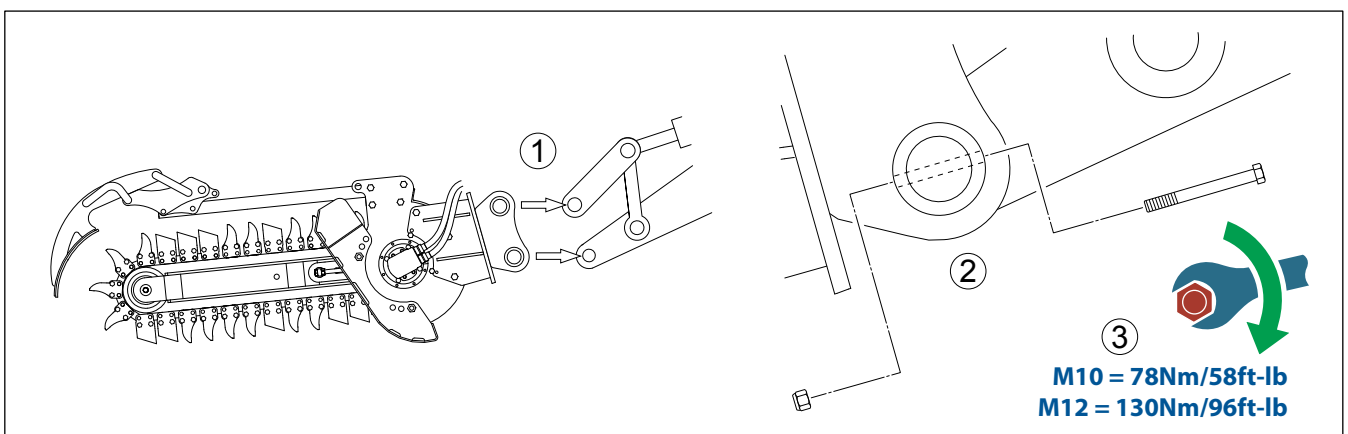

Excavators - Quick Hitch

SAFETY FIRST



Always work in pairs (2 skilled operatives) whenever Trencher Unit components are being assembled or disassembled from the parent machine. Always check the weight of the attachment and ensure you have the correct equipment for handling it.



ALWAYS check parent machine:

- Is in correct working order
- Is parked correctly on flat ground
- Has its hand brake **ON**, its hydraulic circuit locked out and its engine switched **OFF**.

Check that the mounting frame is of the correct model and type to fit the parent machine.
Ensure mounting frame and attachment points are clean before fitting.
Use suitably rated lifting equipment if required (see data plate for weight).



FITTING Ensure all components are greased on assembly:

Refer to the parent machines operators manual for attaching accessories

Fit the mounting frame to the quick hitch coupling and ensure that it is securely locked in position.

Locate the flow and return hydraulic pipes onto the Trencher Unit (see page 17).

Connect quick release couplers.

Check that hydraulic pipes are of sufficient length to allow the Trencher to articulate during work.

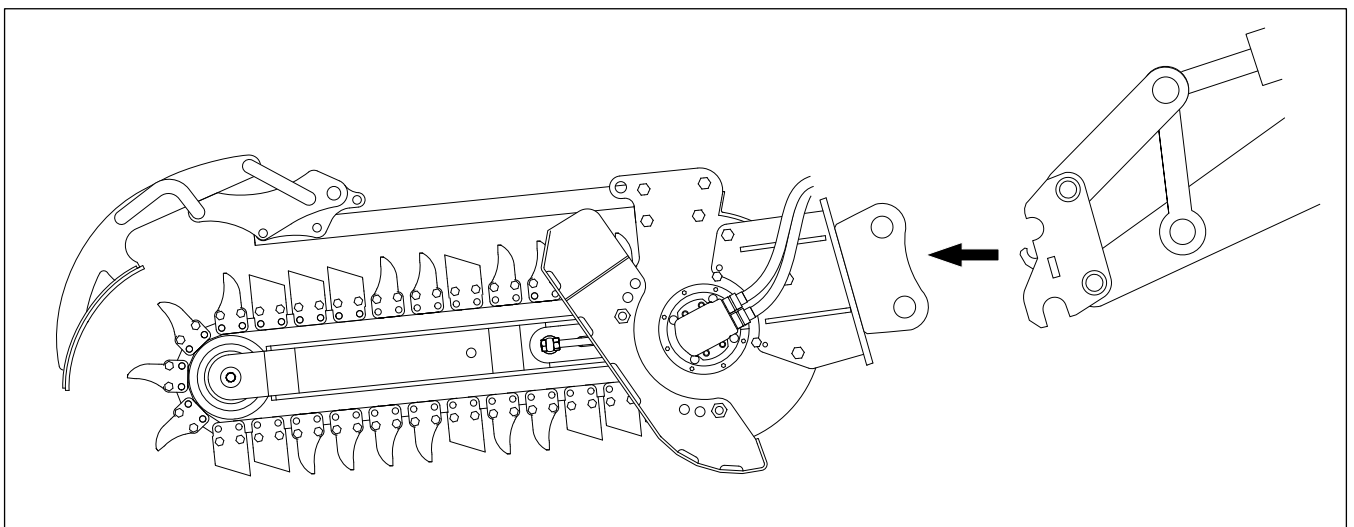

Skid Steer Loaders

SAFETY FIRST

SAFETY FIRST



Always work in pairs (2 skilled operatives) whenever Trencher Unit components are being assembled or disassembled from the parent machine. Always check the weight of the attachment and ensure you have the correct equipment for handling it.



ALWAYS check parent machine:

- Is in correct working order
- Is parked correctly on flat ground
- Has its hand brake **ON**, its hydraulic circuit locked out and its engine switched **OFF**.

Check that the mounting frame is of the correct model and type to fit the parent machine. Ensure mounting frame and attachment points are clean before fitting. Use suitably rated lifting equipment if required (see data plate for weight).



FITTING Ensure all components are greased on assembly:

Refer to the parent machines operators manual for attaching accessories

- 1). Fit mounting frame to parent machine arms.
- 2). Ensure that the unit is securely locked in place using the levers.

Locate the flow and return hydraulic pipes onto the Trencher Unit (see page 17)

Connect quick release couplers.

Check that hydraulic pipes are of sufficient length to allow the Trencher to articulate during work.

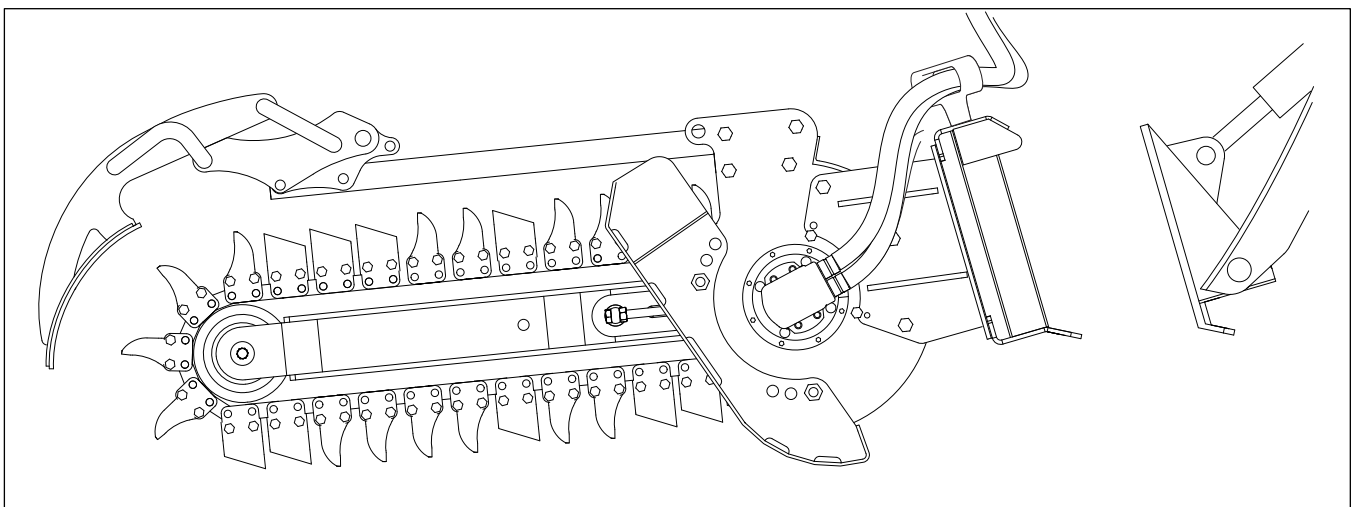

HYDRAULIC CONNECTIONS



WARNING:

Hydraulic fluid under pressure can penetrate the skin or eyes and cause serious personal injury, blindness or death. Fluid leaks under pressure may not be visible. Use a piece of card or wood to find leaks. **DO NOT** use your bare hands. Wear safety goggles to protect your eyes. If any fluid is injected into the skin, it **MUST** be surgically removed. Seek immediate medical attention.

Skid Pro Attachments Trencher Units have been designed for use with specific Skid Pro Attachments mounting frames and Trencher wear parts. Provided these are used and maintained correctly, they will provide a safe and reliable method of trenching in the earth.

All Skid Pro built Trenching Units require a 'flow' and 'return' of hydraulic fluid from the parent machine's auxiliary hydraulic power supply to operate. All Trenchers are reversible and require the host machine to be fitted with a two way flow auxiliary circuit. Check with the parent machine dealer for advice.

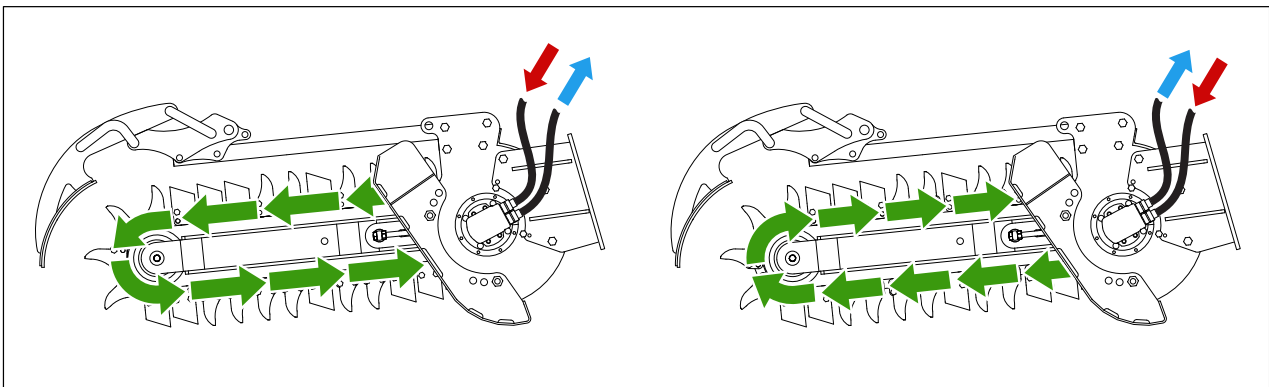

When fitting hydraulic hoses, ensure that they are tightened to the correct torque for the hose fittings.

Some models of Trencher are supplied with hydraulic hoses, but less hydraulic quick release couplers, which are required for connection to parent machine.

These should be sourced locally and be compatible with the auxiliary hydraulic quick release couplers on the parent machine.

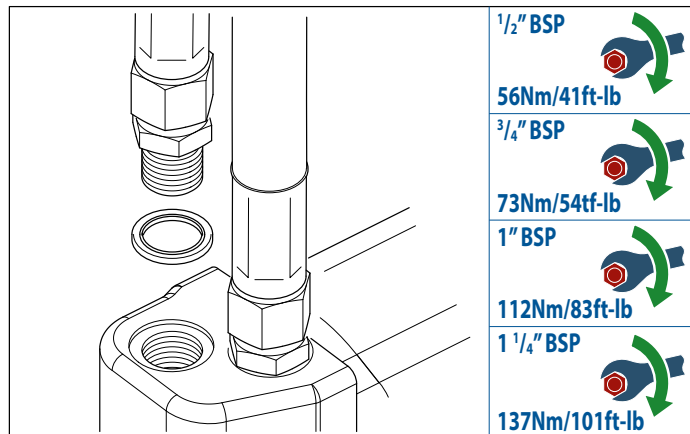

The parent machine auxiliary hydraulic connections are normally located near the end of the loader arms or excavator dipper.

It is critical that the supply of oil is within the stated limits for the particular Trenching Unit;

Check that the rated flow (l/min - gal/min) & pressure (Bar - PSI) of your machine does not exceed the limits shown on the serial plate.

RUNNING-IN

To maximise the life of the motor, it must be run in for a period.

To carry out the running in procedure, suspend the trencher unit clear of the ground, with the boom horizontal.

For the duration of the running in procedure, ensure there are no bystanders within the nominated radius as defined in the risk assessment completed prior to commencing any works.

Operate the motor at 30% of rated pressure for 20 minutes in each direction before application of full operating load.

To further ensure best motor life and maintain warranty, refer to page 25 for lubrication instructions.

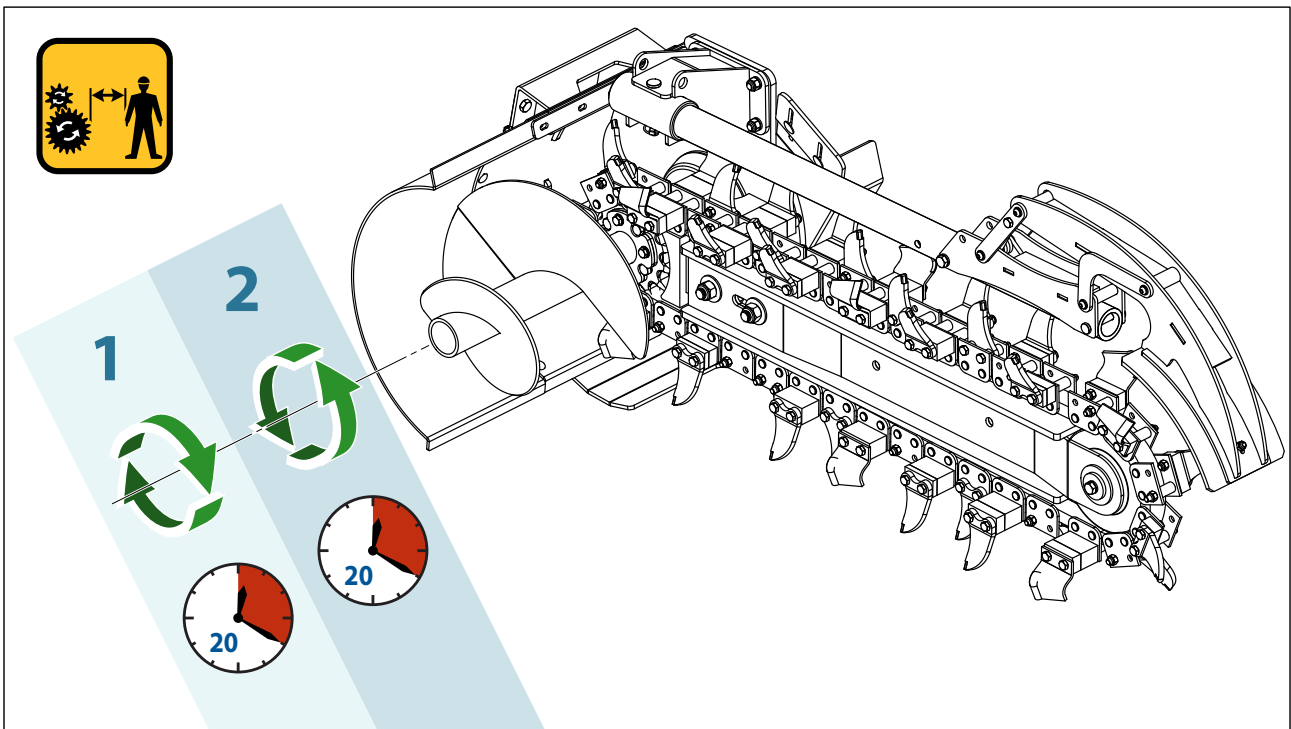

PREPARATION



CONSIDER the topography (e.g. risk of subsidence, slope angle, position to embankments and any previous excavation).



NOTE the type of soil and its condition to enable selection of suitable teeth and pilot

ALWAYS carry out a site survey and risk assessment **BEFORE** starting work



AVOID underground hazards, such as water / gas / electricity / communication lines etc.

If in doubt detection equipment and professional advice should always be considered before carrying out any work.

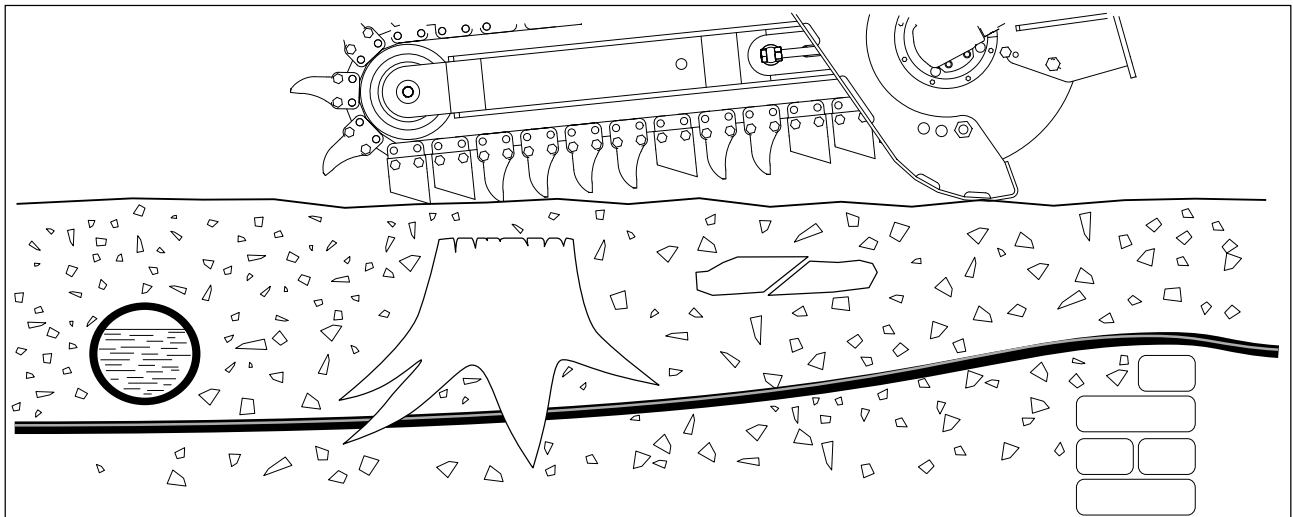

TRENCH DEPTH SETTING

The trenching depth is controlled by the skid plate, which runs with its flat surface on the ground. By changing the angle of the skid plate, the trencher can operate at one of three depth settings.

The skid plate is secured by 2 nuts to studs on the main body as indicated by the arrows. 3 pairs of mounting holes in the skid plate allow the trenching depth to be set as shown in the diagrams below.

Once the trench depth is set, torque the nuts to 138Nm/102ft-lb.

Depth Setting Chart (Dimensions in mm/in.)		MT/MT _{DD} TRENCHER			XHD TRENCHER		
		600	900	1200	900	1200	1500
		300 12	600 24	800 32	600 24	800 32	1000 40
		450 18	750 30	1000 40	750 30	1000 40	1250 50
		600 24	900 36	1200 48	900 36	1200 48	1500 60



138Nm/102ft-lb

SKID SIDE PLATE ADJUSTMENT

To ensure that the left hand side of the trench is free from spoil, the skid is fitted with a side plate to deflect spoil back on to the chain. This ensures that the maximum amount of spoil is removed on the right-hand side by the auger.

Trenchers have an adjustable side plate. This must be adjusted to suit chain width to provide the optimum spoil removal without causing damage to the chain.

Loosen the nuts (A) and adjust the side plate to the correct hole position to for chain fitted to achieve the right clearance between the plate and the widest teeth.

Tighten the nuts.

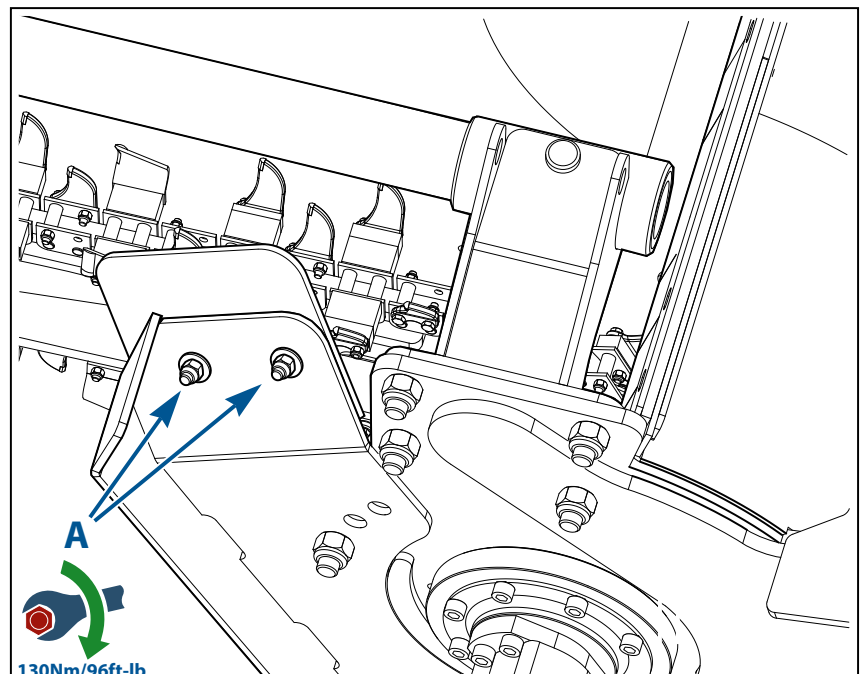
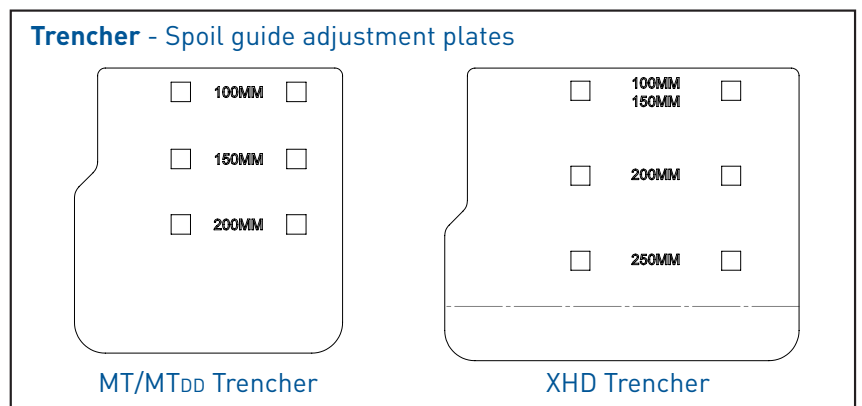

WORKING PROCEDURE

Before commencing work, ensure that ;



The correct hoses are fitted and tightened correctly (See page 24). The unit has been properly run in (See page 30).



There are no bystanders within the nominated radius as defined in the risk assessment completed prior to commencing any works.

- A** Switch off parent machine and ensure the hydraulic system is locked out. Set the Trench Cleaner in it's OPEN position and secure it with linch pin.
- B** Start the parent machine, engage the hydraulic system and ensure that the chain is moving in the correct direction. Set the trencher with the rear of the skid firmly on the ground.
- C** With trencher chain operating and weight applied to the skid plate, GRADUALLY rotate the trencher on so that it penetrates the ground. Always keep the weight on the skid plate while cutting.
- D** When the flat face of the skid plate is firmly in contact with the ground, STEADILY reverse the parent machine. Avoid stalling the chain. After at least 2 metres/6 foot of trenching, STOP the parent machine.

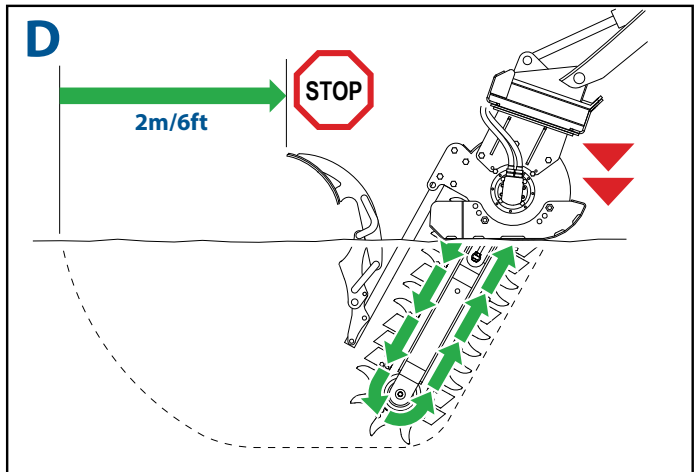
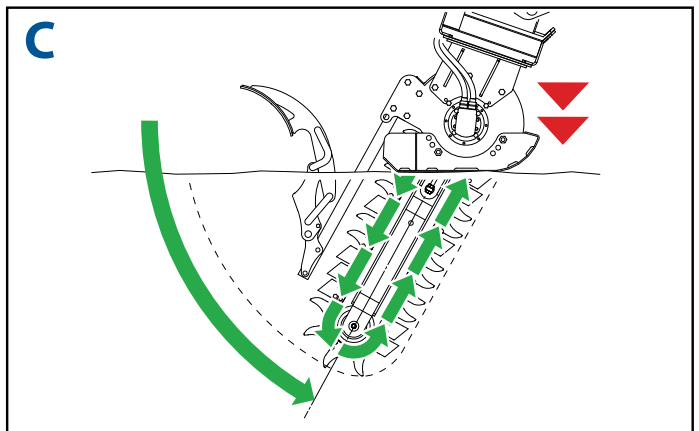
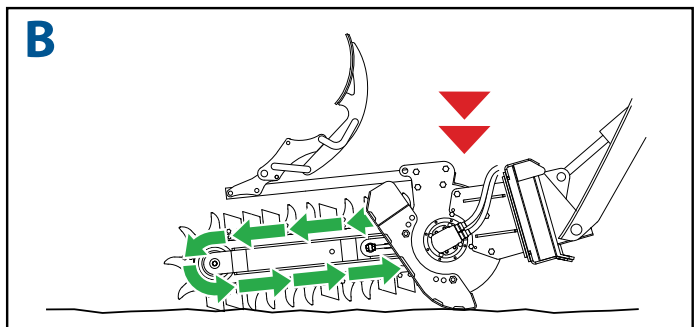
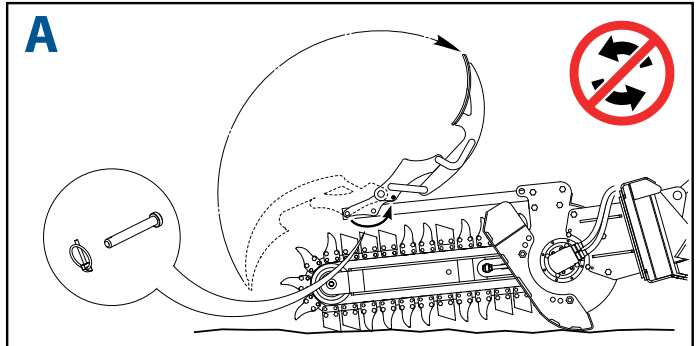

- E** Raise the trencher above ground level Fig E.
Switch off parent machine and ensure the hydraulic system is locked out.
Set the Trench Cleaner in it's CLOSED position and secure it with linch pin.

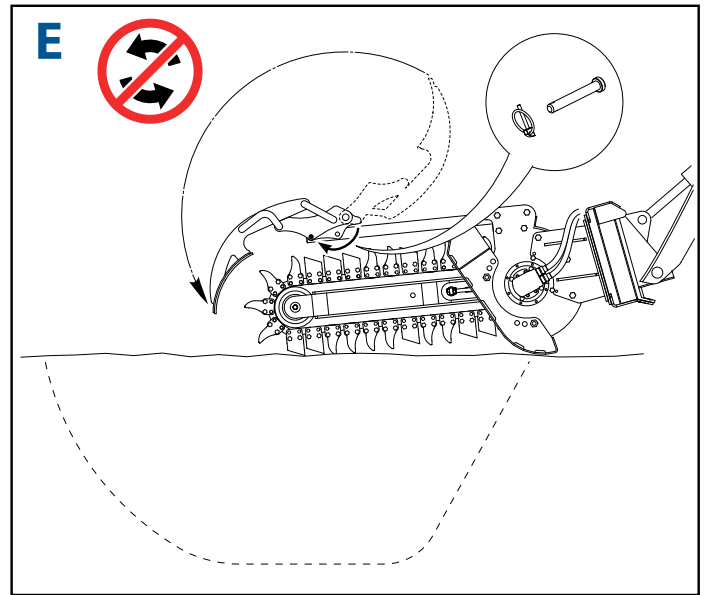

- F** Start the parent machine, engage the hydraulic system and lower the trencher into the trench until the flat face of the skid plate is firmly on the ground with weight applied and continue trenching Fig F

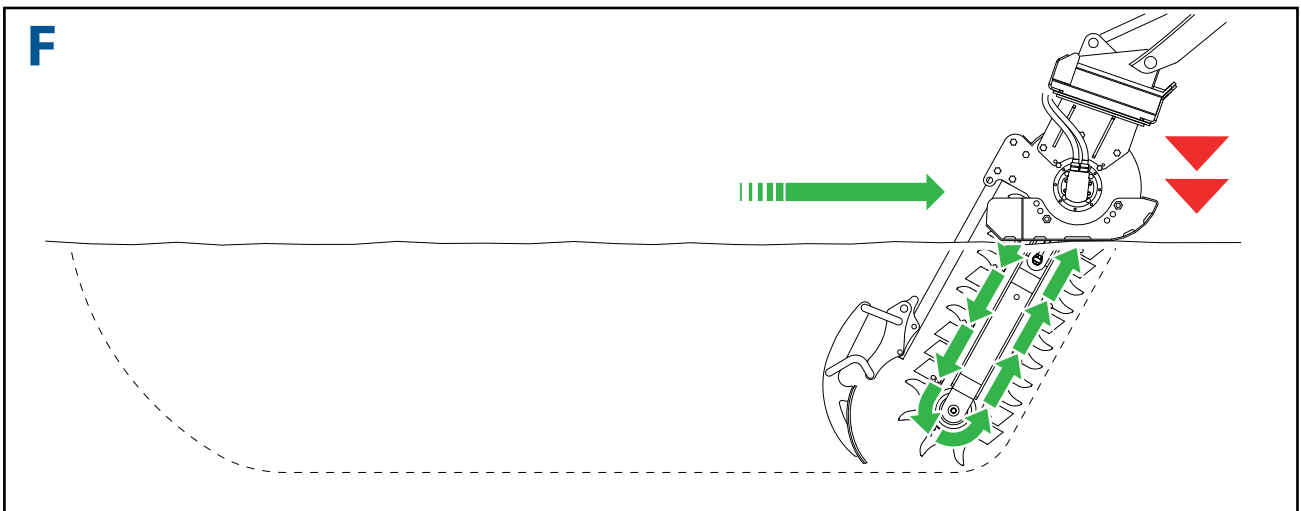

TRANSPORTATION

Transportation On Public Highways



ALWAYS remove the Trencher Unit before driving or transporting the parent machine on public highways.

ALWAYS store the Trencher Unit securely and safely when removed from the parent machine taking special care of the hydraulic hoses and connections.

Transportation Within The Job Site



ALWAYS disengage the rotation of the Trencher chain, whenever operating the parent machine, whilst the Trencher Unit is not trenching.

ALWAYS operate the parent machine slowly when on site, keeping the Trencher Unit as close to the parent machine and as low as possible.

The best travelling positions for Excavator and Skid Steer loader are shown below.

Recommended Travel Position

Excavator

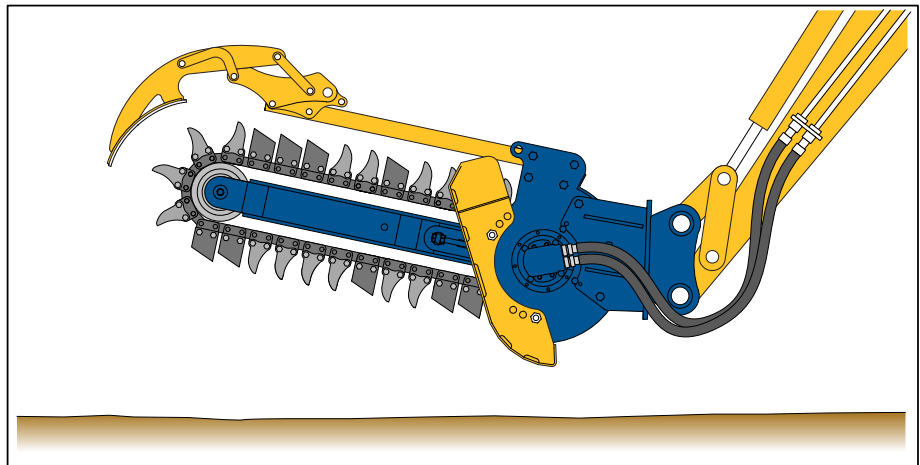

Skid Steer Loader

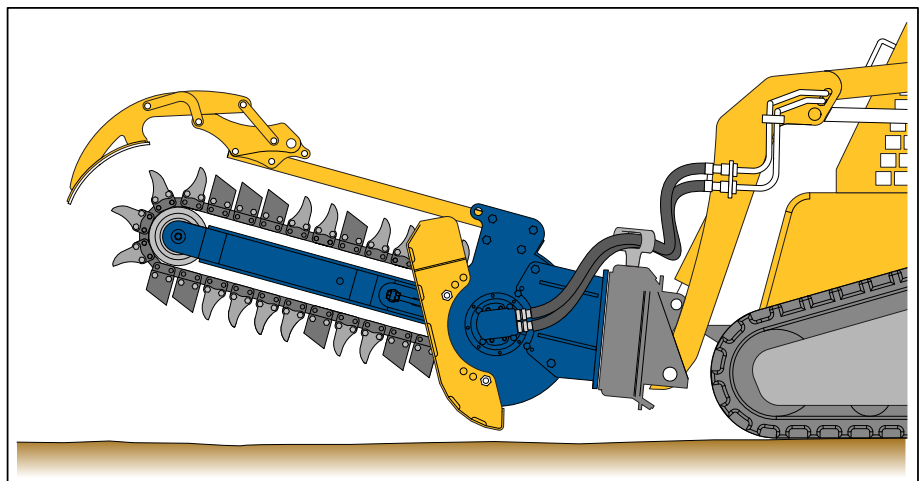

MAINTENANCE & LUBRICATION

SAFETY



Safety at all times



Ensure environmentally safe disposal of waste oil:

Do not pour down drain!



Avoid Fire or Explosion:

Do not smoke near, or expose lubricants to, any possible sources of ignition (e.g. fire, electrical sparks or heat sources.)



All lubricants are toxic and potentially carcinogenic (cancer causing).



Avoid contact with skin and eyes:

Wear suitable protective clothing and gloves.



Always use a suitable barrier cream in case of skin contact.



Always wear eye protection:

In the event of skin contact wash with soap and water.

In the event of eye contact wash with water and seek medical advice.



Do not ingest:

If swallowed seek medical advice immediately.

Routine Maintenance:

After your first 50 meters/160 foot of trenching, raise the Trencher unit and check the chain tension.

Refer to page 28 for chain adjustment instructions. Chain tension should be checked after every 500 metres/550 yards of trenching.

Your Skid Pro Attachments Trencher Unit features a sealed gear housing filled with gear oil to lubricate the planetary gear set components and bearings within the housing.

Skid Pro Built Trencher Units are low maintenance, however regular checks for oil leaks and following the service schedules are recommended to ensure a trouble free product.

Daily checks:

Check Chain adjustment (see page 28).

Check Tooth wear.

Check Condition of nose roller assembly.

Check for oil leaks.

Weekly checks (in addition to daily checks):

Check overall condition of the Trencher unit and Mounting frame.

Check drive sprocket for wear (see page 32 & 33 for correct replacement details).

Check hydraulic hoses for any damage.

After first 100 hours of operation or six (6) months:

To maximise life and maintain warranty the Trencher Unit gear oil requires draining and replacing with Mobil Gear 600XP (or equivalent) after the first 100 hours of operation or six (6) months from date of purchase – whichever occurs first (see page 27 for oil change details).

Yearly or after every 500 hours of use (whichever is sooner):

The Trencher Unit gear oil requires draining and replacing with Mobil Gear 600XP (or equivalent) every twelve (12) months or 500 hours – whichever occurs first.

Oil capacity

Refer to page 27 for the correct volume of oil for your trencher.

If in doubt contact Auger Torque Europe Ltd. or your nearest dealer.

Oil Change Procedure



Before starting any maintenance work on this unit read the instructions carefully and ensure you have the correct tools, materials and safety equipment to hand.



Pre-heat the oil by running the unit for 15 minutes.

Ensure that the unit is securely supported so that you have safe access to the underside of the drive unit.

Locate the fill plug in the top of the output housing and the drain plug in the bottom of the housing (Fig. A).

To ensure that the unit drains completely, make sure that the boom is horizontal (Fig. B).

Place a tray beneath the unit to catch the oil. Remove the fill plug, then the drain plug (Fig. C).

Allow the oil to drain for 10 minutes (Fig. D).

Replace the drain plug and add the correct quantity of Mobil Gear 600XP ISO320 gear oil;

MT: 0.8 litres/1.7 US pints

DDT: 0.4 litres/0.8 US pints

XHD: 0.8 litres/1.7 US pints

Replace the fill plug and ensure both plugs are tightened securely.

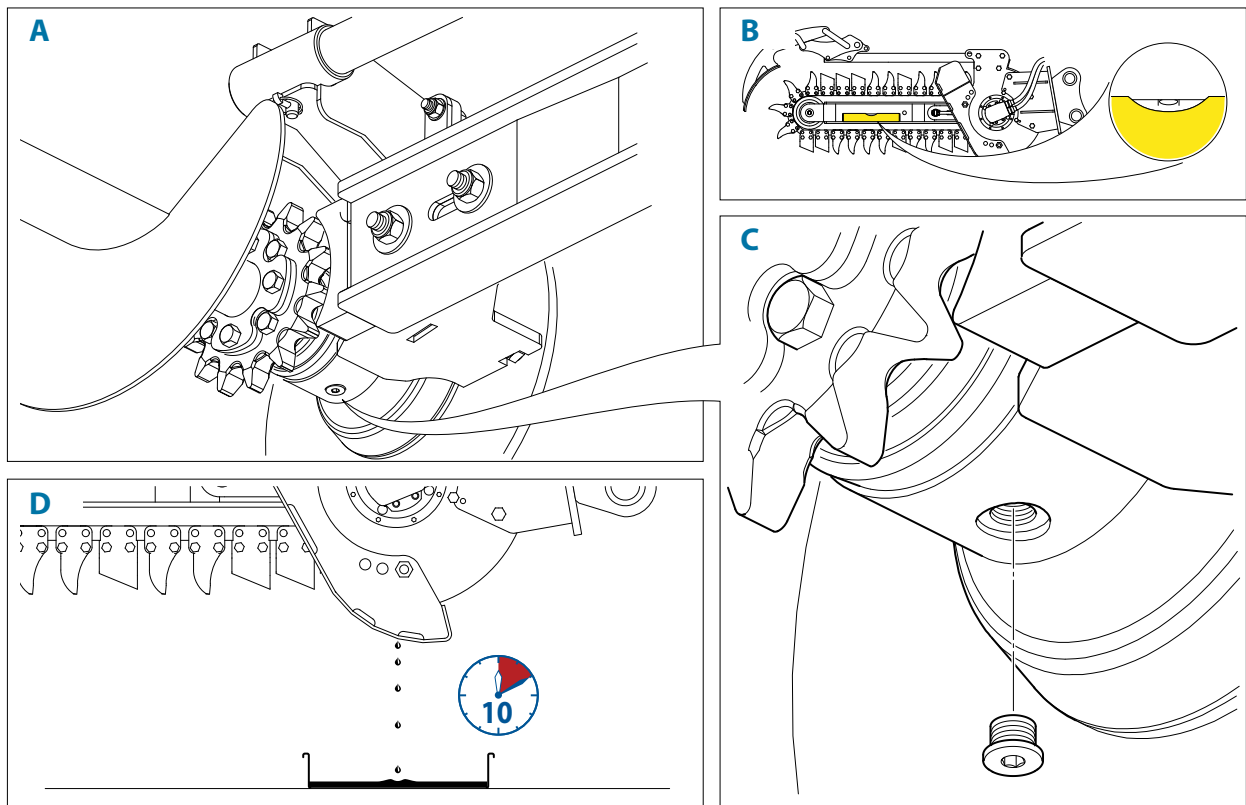

Chain Adjustment (If purchased after Oct 2025, go to the next page.)

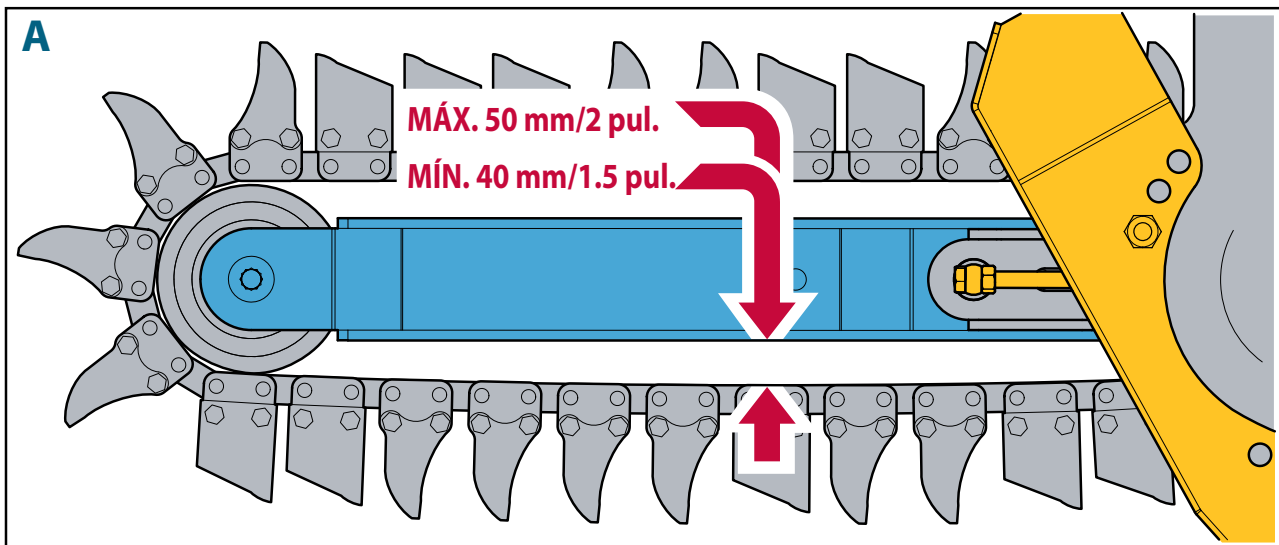

Check the chain tension by measuring the clearance between the chain and the boom as shown in Fig A.

Step 1

The correct clearance should be between a minimum of 40mm/1.5in and a maximum of 50mm/2in.

If adjustment is necessary, loosen the two nuts (1) on the auger side of the boom Fig B.

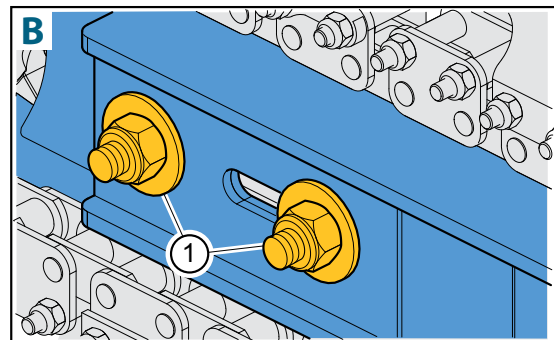

Step 2

Loosen the tensioner locknut (2) Fig C and adjust the tension by turning the screw (3) as shown in the diagram.

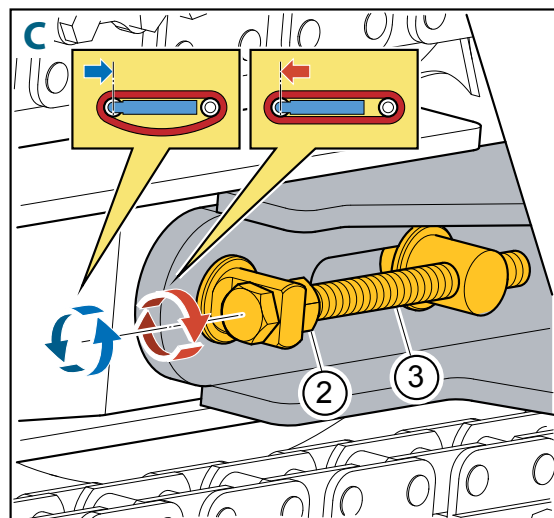

Step 3

Check the chain tension as shown in Fig A and re-adjust as necessary until the correct clearance is achieved.

Step 4

Tighten the locknut (2) Fig C.

Step 5

Tighten the two nuts (1) Fig B using the torque values in Fig D.

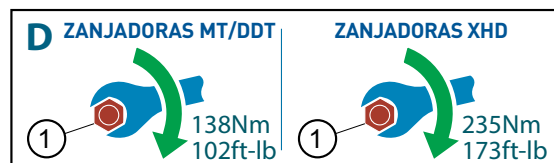

CHECK THAT ALL NUTS ARE RE-TIGHTENED BEFORE OPERATING THE TRENCHER

Chain Adjustment

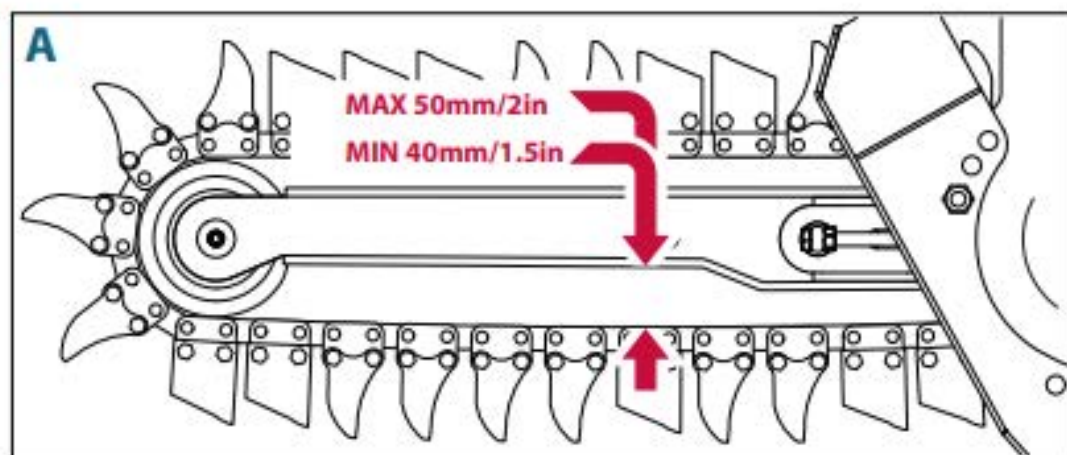

Check the chain tension by measuring the clearance between the chain and the boom as shown in Fig A.

The correct clearance should be between a minimum of 70mm (2 3/4in) and a maximum of 80mm (3 1/8in). If adjustment is necessary:-

Step 1

Loosen the two nuts (1a 1b) on the auger side of the boom Fig B.

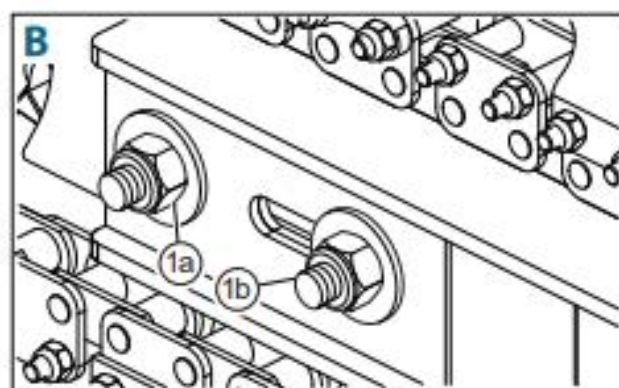

Step 2

Loosen the tensioner locknut (2) Fig C and adjust the tension by turning the screw (3) as shown in the diagram.

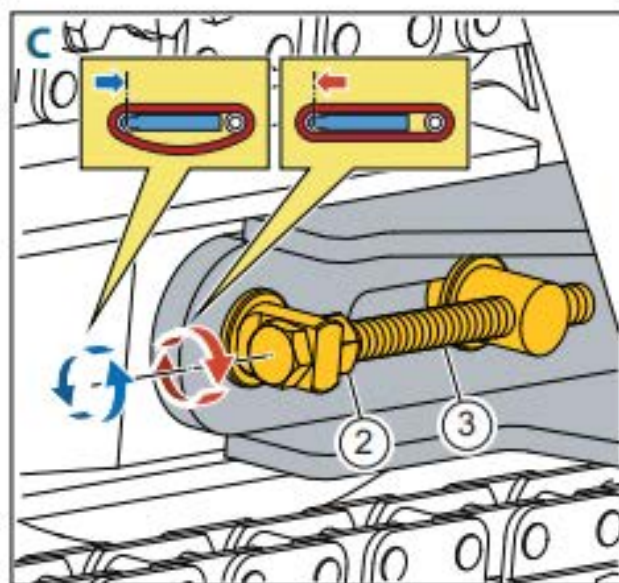

Step 3

Check the chain tension as shown in Fig A and re-adjust as necessary until the correct clearance is achieved. Tighten the locknut (2) Fig C.

Step 4

Tighten nut (1a) Fig B using the torque values in Fig D. Loosen tensioner screw (3) Fig C half turn, then tighten nut (1b) Fig B.

Step 5

Re-set tensioner screw and locknut (2 & 3) Fig C.



WARNING: If nuts (1a 1b) are tightened whilst tensioner screw (3) is locked, adverse pressure is put on the tensioner resulting in possible failure.

CHECK THAT ALL NUTS ARE RE-TIGHTENED BEFORE OPERATING THE TRENCHER

Chain Removal/Replacement



The chain ends are joined with a pin, which is secured with a split cotter pin.

Ensure that the chain is slackened off completely, following the 'Chain Adjustment' instructions on page 28.

Locate the joining pin and rotate the chain so that you have easy access to both ends of the pin.



CAUTION: Once the joining pin is removed, the weight of the chain will cause it to swing or fall, take care to either secure the chain or make sure that it will not cause any damage when released.

Remove the split pin and press out the joining pin.

Replacement is the reverse of removal, apply grease to the holes and pin before fitting.

Fit a new split pin and ensure that the ends of the split pin are securely bent over before running.

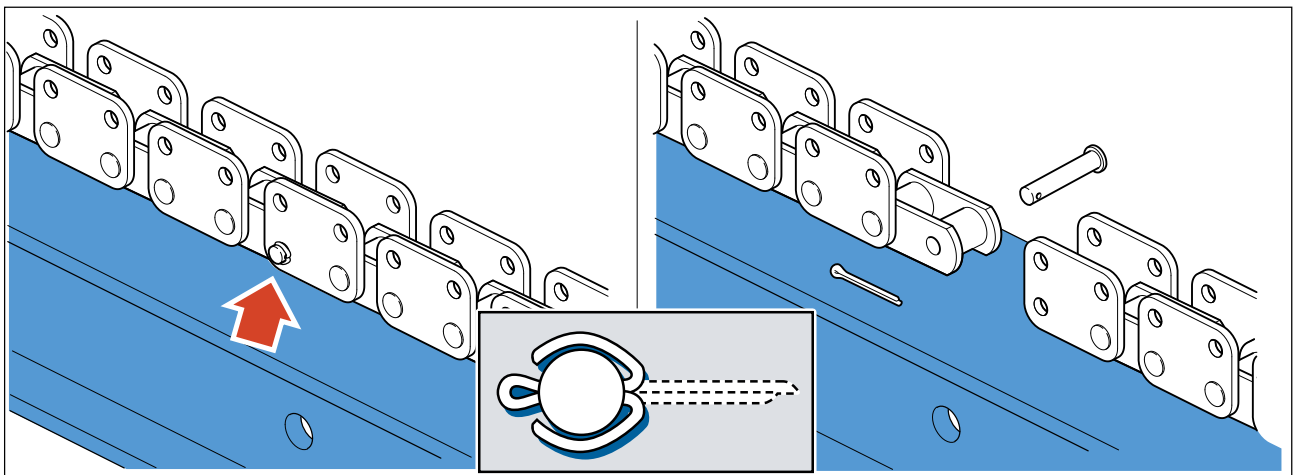

CAUTION: Before operating the trencher, set the chain tension following the 'Chain Adjustment' instructions on page 28.

Cutting Tooth Maintenance

To cope with different types of trenching conditions, Skid Pro Attachments trenching chains are supplied fitted with interchangeable 'Earth' or 'Tungsten' teeth, or a combination of both types (Fig A).

The teeth are bolted directly to the chain, or with spacers to provide a range of trench widths.

After prolonged use, the cutting teeth will show signs of wear and eventually become inefficient.

Fig B shows acceptable levels of wear for the earth teeth.

Tungsten tooth wear limits are shown in Fig C.

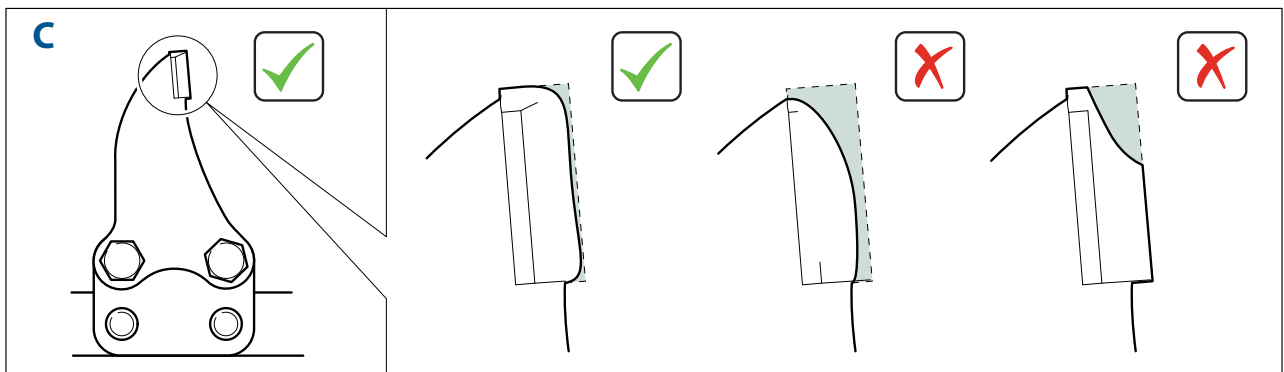
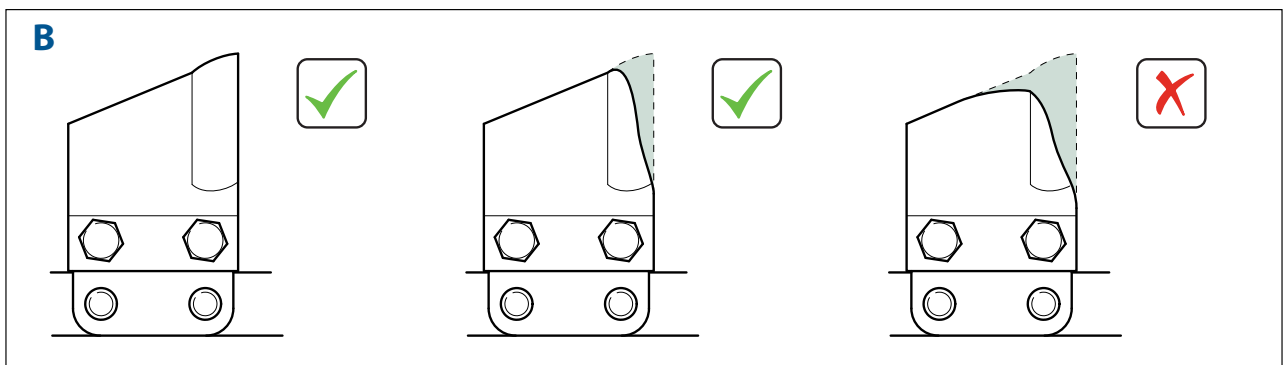
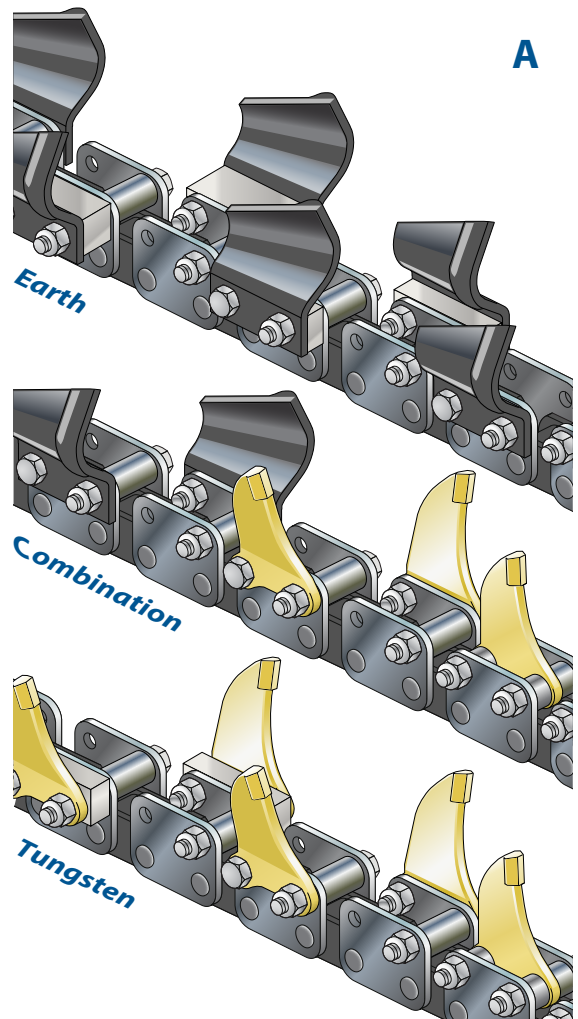

Nose Roller Bearing Replacement

To remove the Nose Roller, first remove the chain as described in 'Chain Removal/Replacement' on page 29.

A The Nose Roller is attached by 2 bolts, 2 spring washers and 2 special washers, which secure a square pin between the ears of the boom. Removing either of the bolts with its washers will enable the square pin to be withdrawn and free the nose roller. The bearing is retained by a shoulder on one side and circlip on the other.

B Remove the circlip with a pair of internal circlip pliers.

C Press out the bearing, ensuring that the roller is supported close to the opening, leaving enough space below for the bearing to clear the hole.

D To fit a new bearing, invert the roller on a flat surface. Check the mating surfaces and the circlip groove to ensure they are clear of obstructions. Press in the new bearing with an adaptor that applies pressure only to the outer journal of the bearing. Ensure that the bearing clears the circlip groove and sits against the shoulder at the bottom of the hole. Refit the circlip.

Refit the nose roller (refer to Fig A for correct sequence of components).

E Tighten both bolts to 120Nm/88ft-lb.

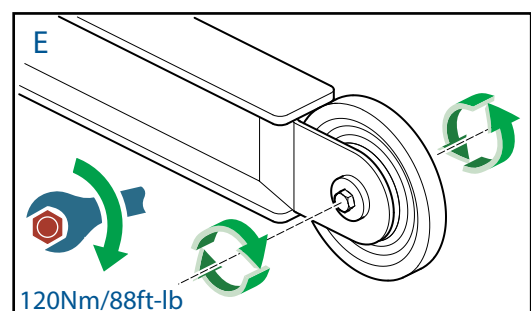
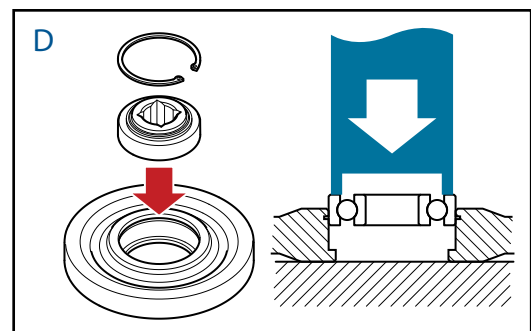
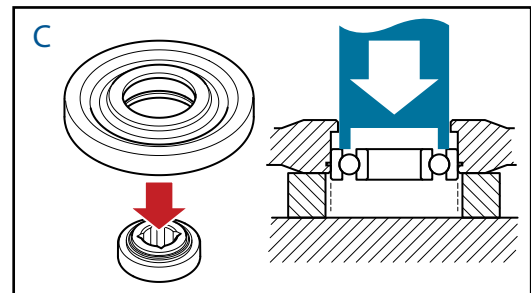
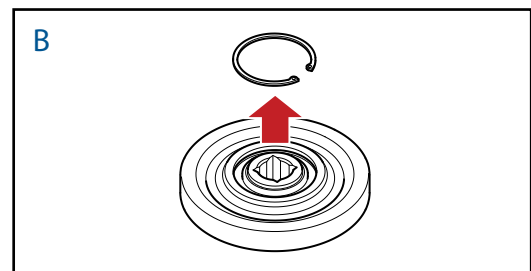
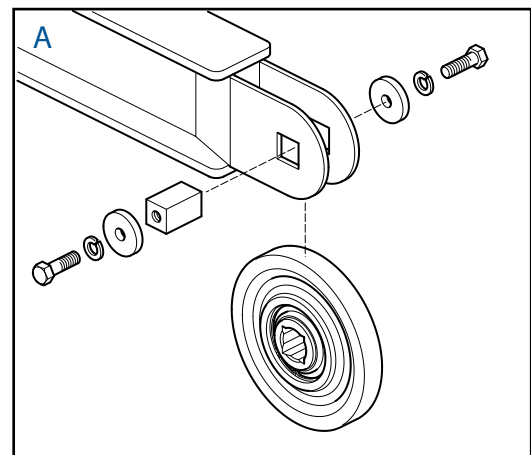

Sprocket Removal & Replacement - MT/MT_{DD} Trencher

To remove the sprocket, first remove the chain as described in 'Chain Removal/Replacement' on page 29.

Step 1

Spoil auger removal. Ensure hydraulic oil supply has been disconnected. Secure the trencher in a stable position. Remove fasteners assembly (1) from the spoil auger (2). Retract the spoil auger (2) from the output shaft (3).

Refitting is the reverse of removal; ensure the fastener assembly is tightened to a torque of 130Nm/96ft-lb.

Step 2

Sprocket removal. Rotate the sprocket until the locating key (4) and setscrew (5) are visible.

Loosen the setscrew and slide the sprocket from the output shaft.

Prior to fitting a new sprocket, ensure that the shaft is free from dirt and debris and apply grease to the mating surfaces.

Slide the sprocket on to the shaft ensuring that the key aligns with the slot and the sprocket is tight against the seal protector before tightening the setscrew.

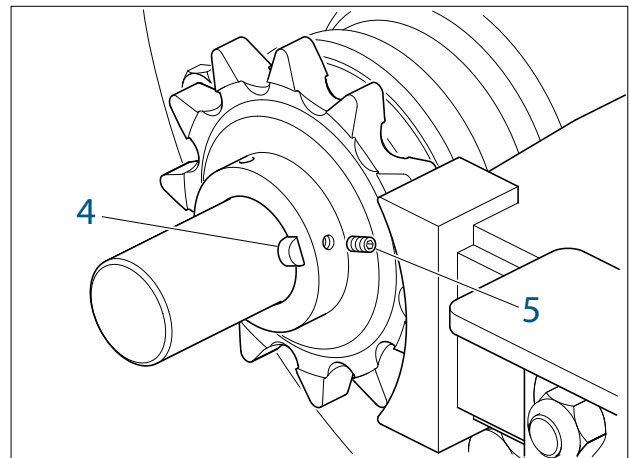
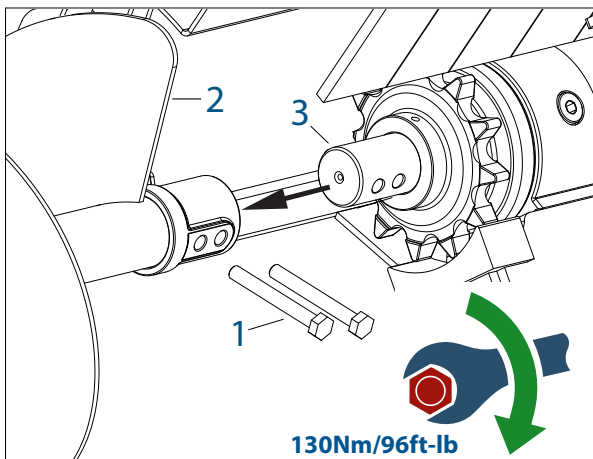

Sprocket Removal & Replacement - XHD Trencher

To remove the sprocket, first remove the chain as described in 'Chain Removal/Replacement' on page 29.

Step 1

Spoil auger removal. Ensure hydraulic oil supply has been disconnected. Secure the trencher in a stable position. Remove fasteners assembly (1 & 2) from the spoil auger (3). Retract the spoil auger (3) from the output shaft (4).

Refitting is the reverse of removal; ensure the fastener assembly is tightened to a torque of 120Nm/88ft-lb.

Step 2

Sprocket removal. Remove fastener assembly (5 & 6)

Remove sprocket (7)

Prior to fitting a new sprocket, ensure that the shaft is free from dirt and debris and apply grease to the mating surfaces.

Refitting is the reverse of removal; ensure the fastener assembly is tightened to a torque of 120Nm/88ft-lb.

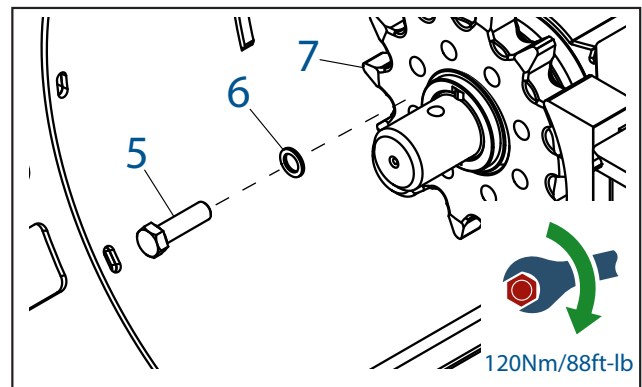
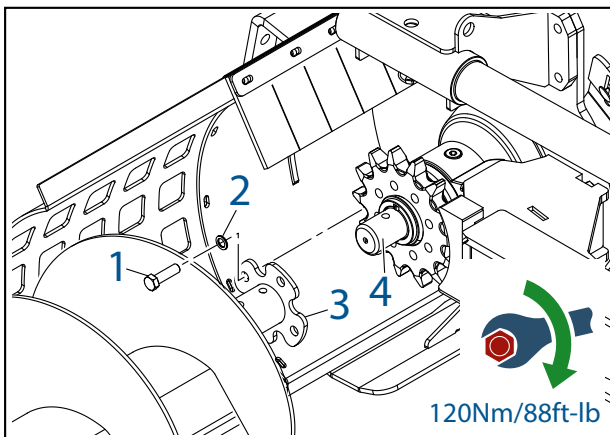

TROUBLESHOOTING

IF IN DOUBT ASK! - Seek Skid Pro Attachments / parent machine dealer for advice & repair. **BE SAFE** - only use genuine Auger Torque / parent machine spare parts.

MOUNTING FRAME - ASSEMBLY		
FAULT	POSSIBLE CAUSE	ACTION
Mounting frame does not fit parent machine	Incorrect or non-genuine mounting frame being used Damaged / worn parts	Refer to both this manual and parent machine's operating assembly instructions Repair or replace with genuine mounting frame
MOUNTING FRAME - OPERATION		
FAULT	POSSIBLE CAUSE	ACTION
Excessive movement in locating pins	Incorrect or worn locating pins Parent machine pin location / linkage frame pin location worn Damaged parts	Replace with correct new parts Seek advice from parent machine dealer Seek advice from Skid Pro Attachments / parent machine dealer. Only use genuine spare parts
TRENCHER UNIT - ASSEMBLY		
FAULT	POSSIBLE CAUSE	ACTION
Trencher Unit will not fit mounting frame	Incorrect / incompatible or non genuine mounting frame / Trencher Unit Damaged parts	Obtain & fit correct and compatible genuine parts Seek advice from Skid Pro Attachments dealer. Only use genuine spare parts
Excessive movement in locating pins	Incorrect or worn pins	Replace with correct new genuine parts
TRENCHER UNIT - OPERATION		
FAULT	POSSIBLE CAUSE	ACTION
Trencher drive output shaft does not rotate	No oil flow	Check that quick release coupler(s) are correctly engaged to parent machine Check that parent machine hydraulic system is operating correctly and has sufficient oil of the correct grade (refer to parent machine operating instructions)

TRENCHER UNIT - OPERATION

FAULT	POSSIBLE CAUSE	ACTION
Trencher drive output shaft does not rotate	<p>Parent machine pressure relief valve faulty or set too low</p> <p>Trencher unit seized</p> <p>Trencher jammed in ground</p>	<p>Test, reset or replace to parent machine's specification</p> <p>Seek advice from Skid Pro Attachments dealer</p> <p>Reverse Trencher Chain</p>
Slow Trenching speed / slow rotation of Trencher Unit output shaft	<p>Insufficient oil flow from parent machine</p> <p>Incompatible Trencher Unit to parent machine combination</p> <p>Worn Trencher Unit hydraulic motor possibly due to incorrect or dirty oil supply</p>	<p>Check that parent machine hydraulic two way flow system is operating correctly and has sufficient oil of the correct grade</p> <p>Check specification. Seek advice from Skid Pro Attachments dealer</p> <p>Seek advice from Skid Pro Attachments dealer. Only use genuine spare parts.</p>
Trencher stalls during work	<p>Parent machine pressure relief valve faulty or set too low</p> <p>Restricted oil flow</p> <p>Blocked hydraulic filter</p> <p>Excessive parent machine pull on Trencher</p> <p>Insufficient parent machine hydraulic pressure</p> <p>Incompatible Trencher / parent machine combination</p>	<p>Change parent machine hydraulic oil and filter before fitting replacement drive unit</p> <p>Reset/replace pressure release valve to parent machine's specification</p> <p>Check for damaged or incorrect hydraulic hoses and connections</p> <p>Change parent machine filter and oil</p> <p>Reduce machine pull on Trencher</p> <p>Check that parent machine oil pressure meets with Trencher Unit requirements</p> <p>Check specification. Seek advice from Skid Pro Attachments dealer</p>

MT600 - MT900 Trencher - Parts List

MT900 from Serial Number 450920001

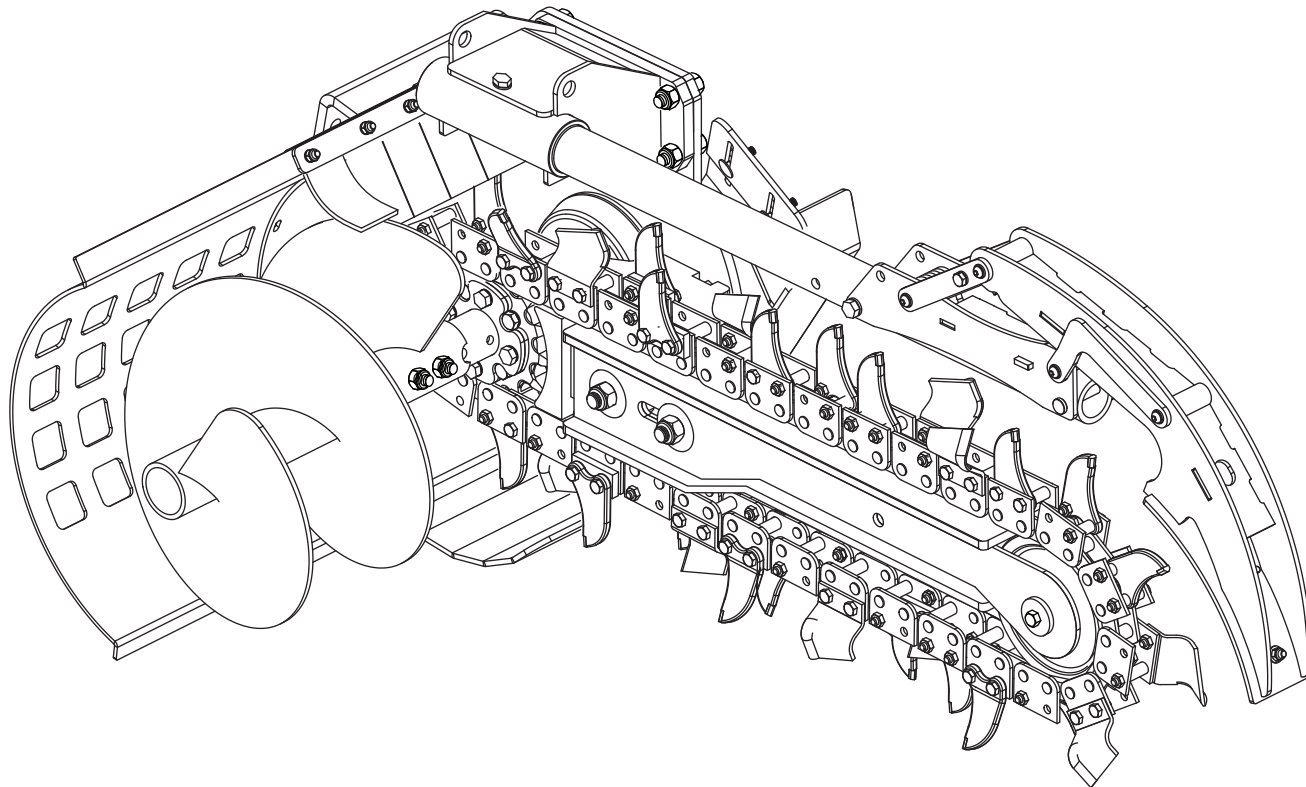

MT600 - MT900 Trencher - Parts List

MT900 from Serial Number 45092000+

FOREWORD

This document is the property of Skid Pro and the information contained herein is confidential to the company. The contents of the document must not be reproduced or disclosed wholly or in part, or used for purposes other than that for which it has been supplied, without the prior written permission of Skid Pro.

Doc No: 99-95400901-REV-02 Date: 12-2024

WARRANTY

Skid Pro is not responsible for nor will accept any charges for work carried out by any unauthorised repairers. Charges, including those for spare parts, will not be accepted unless they have been authorised in writing by Skid Pro.

Any goods returned to Skid Pro by the customer, under warranty or for repair, must be freight paid unless authorised in writing by Skid Pro.

MT600 - MT900 Trencher - Parts List

MT600 from Serial Number 410620001

MT900 from Serial Number 450920001

SYMBOLS AND ABBREVIATIONS

The symbols that follow are used within this publication



Safety Glasses to be worn



Gloves/hand protection to be used



Safety shoes to be worn



Torque Tightening required

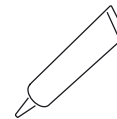

Thread treatment required



Refer to Interchangeability Chart

MT600 - MT900 Trencher - Parts List

MT900 from Serial Number 450920001

ILLUSTRATED PARTS LIST.

- A The Illustrated Parts List helps the supply procedure and the identification of replacement component parts.
- B The Detailed Parts List is divided into seven columns:
- The first column gives the item number of each detailed part contained in the illustration. An item number prefixed by a (-), shows that the item is not illustrated.
 - The second column gives the part number by which the item is identified.
 - The third column, gives the description of the component. The description will be preceded by one or more dots (●).
 - The fourth column gives the quantity of each item in the complete assembly.
 - The fifth column shows the torque tightening required for the item.
 - The sixth column shows the thread treatment required for the item.
 - The seventh column makes reference to any additional information required for the part or assembly.
- C Only those items with full dots (●) can be ordered as spares. Items with empty dots (eg ●○) are shown only for clarity of assembly and cannot be ordered as spares.

- D When ordering spare parts please quote the serial number of the trencher, which can be identified from the serial number plate on the top of the unit.

The abbreviations that follow are used within this publication

AR	As Required
BSP	British Standard Pipe Thread
cc	Cubic Centimeters
Kg	Kilogrammes
L	Litres
LPM	Litres Per Minute
Mm	Millimeters
Nm	Newton Meters
UNC	Unified Coarse Thread
GPM	Gallons Per Minute
G	Gallons
lbs	Pounds
ft-lbs	Foot Pounds

MT600 - MT900 Trencher - Parts List

MT900 from Serial Number 450920001

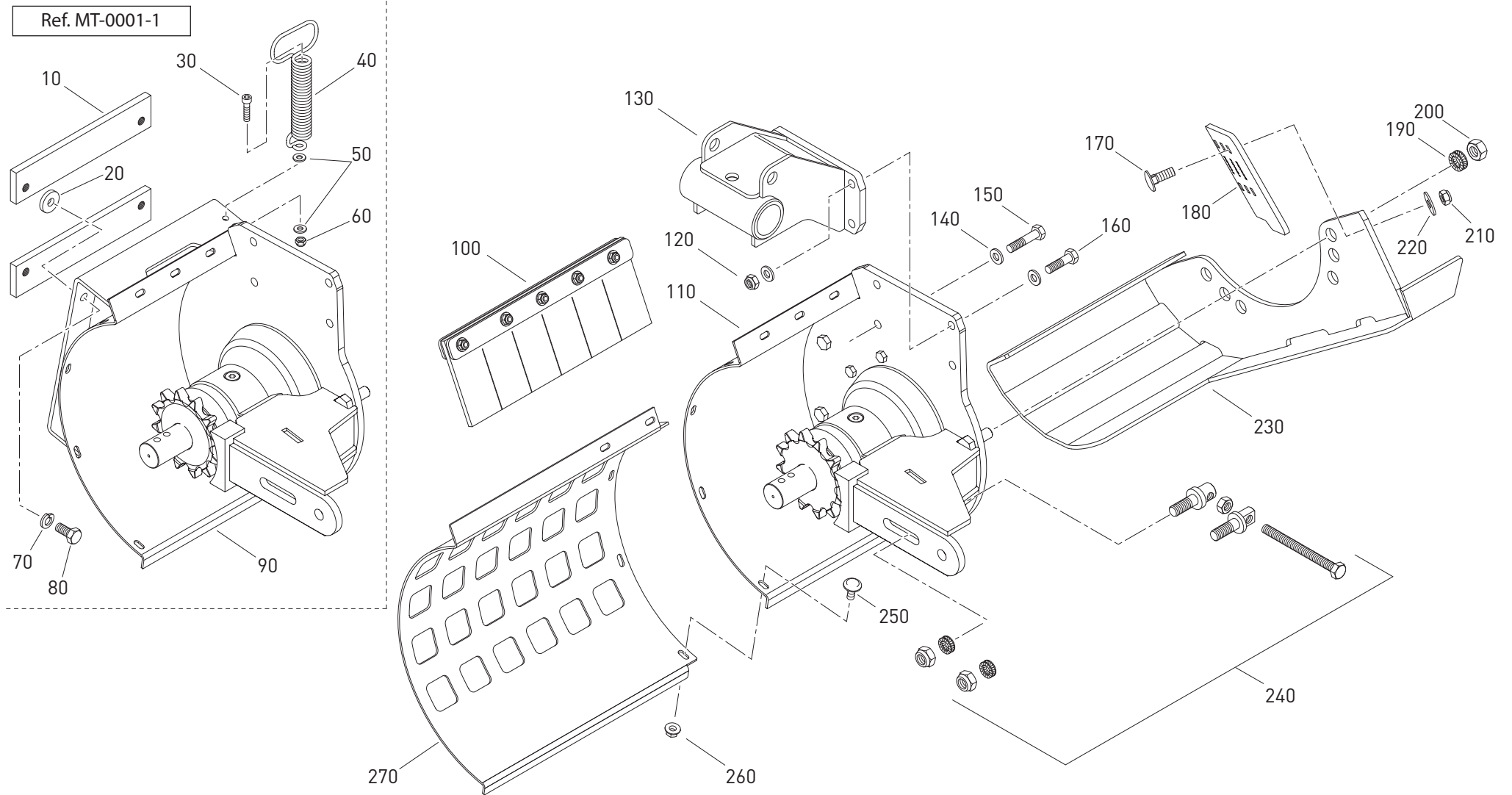

MT600 - MT900 Trencher - Parts List

MT900 from Serial Number 450920004

ITEM	PART NO.	DESCRIPTION	QTY	TORQUE LOAD	THREAD TREATMENT	NOTES
10	45-1039	• PLATE - CLAMP SIDESHIFT (SKIDSTEER)	2			
20	19-0053-43	• SPACER - SIDESHIFT (SKIDSTEER)	4			
30	99-9134-035-Y	• FIXING - SKT HD CAP M10 x 35 (12.9 Grade) (SKIDSTEER)	1			
40	99-7922	• SPRING HOSE RETAINER (SKIDSTEER)	1			
50	99-9154-P	• FIXING - M10 PLAIN "PENNY" WASHER (SKIDSTEER)	2			
60	99-9184	• FIXING - M10 METRIC NYLOC NUT (SKIDSTEER)	1			
70	99-9166	• FIXING - SPRING WASHER - M16 H/D (SKIDSTEER)	4			
80	99-9125-035	• FIXING - M12 x 35MM - SETSCREW (8.8 Grade) (SKIDSTEER)	4			
90	45-1948	• DRIVE SUB ASSEMBLY - (SKIDSTEER)	1			
100	45-1907	• KIT-RUBBER FLAP/PLATE AND FIXINGS	1			
110	45-1943	• DRIVE SUB ASSEMBLY - (EXCAVATOR/MINI LOADER)	1			
120	99-9186	• FIXING - NUT NYLOC M16 (8.8)	4			
130	45-1952	• MT600/900 DANGER BAR MTG. FAB	1			
140	99-9156	• FIXING - WASHER - M16	8			
150	99-9126-075	• FIXING - M16 x 75MM - BOLT (8.8 Grade)	1			
160	99-9126-060	• FIXING - M16 x 60MM - SETSCREW (8.8 Grade)	3			
170	99-9205-035	• FIXING - M12X35 CUP SQ SETSCREW (DIN603)	2			
180	45-1045	• SKID PLATE MT ADJUSTABLE CHAIN WIDTH 100-200	1			
190	99-9237	• FIXING - WASHER ANTIVIBRATION NORD M20 -SP	2			
200	99-9177	• FIXING - NUT PLAIN M20	2			
210	99-9185	• FIXING - M12 METRIC NYLOC NUT	2			
220	99-9155-P	• FIXING - PENNY WASHER - M12 - FORM G	2			
230	45-1901	• SKID PLATE WELD ASSY MT600/900	1			
240	42-1902	• BOOM ADJUSTMENT KIT	1			
250	99-9204-025	• FIXING - COACH BOLT M10 X 25 LONG (8.8 Grade)	4			
260	99-9194	• FIXING - NUT FLANGED - M10	4			
270	45-1035	• GUARD - BOLT-ON TRENCHER	1			

Ref. MT-0001-1

MT600 - MT900 Trencher - Parts List

MT900 from Serial Number 450920001

Ref. MT-0002-1

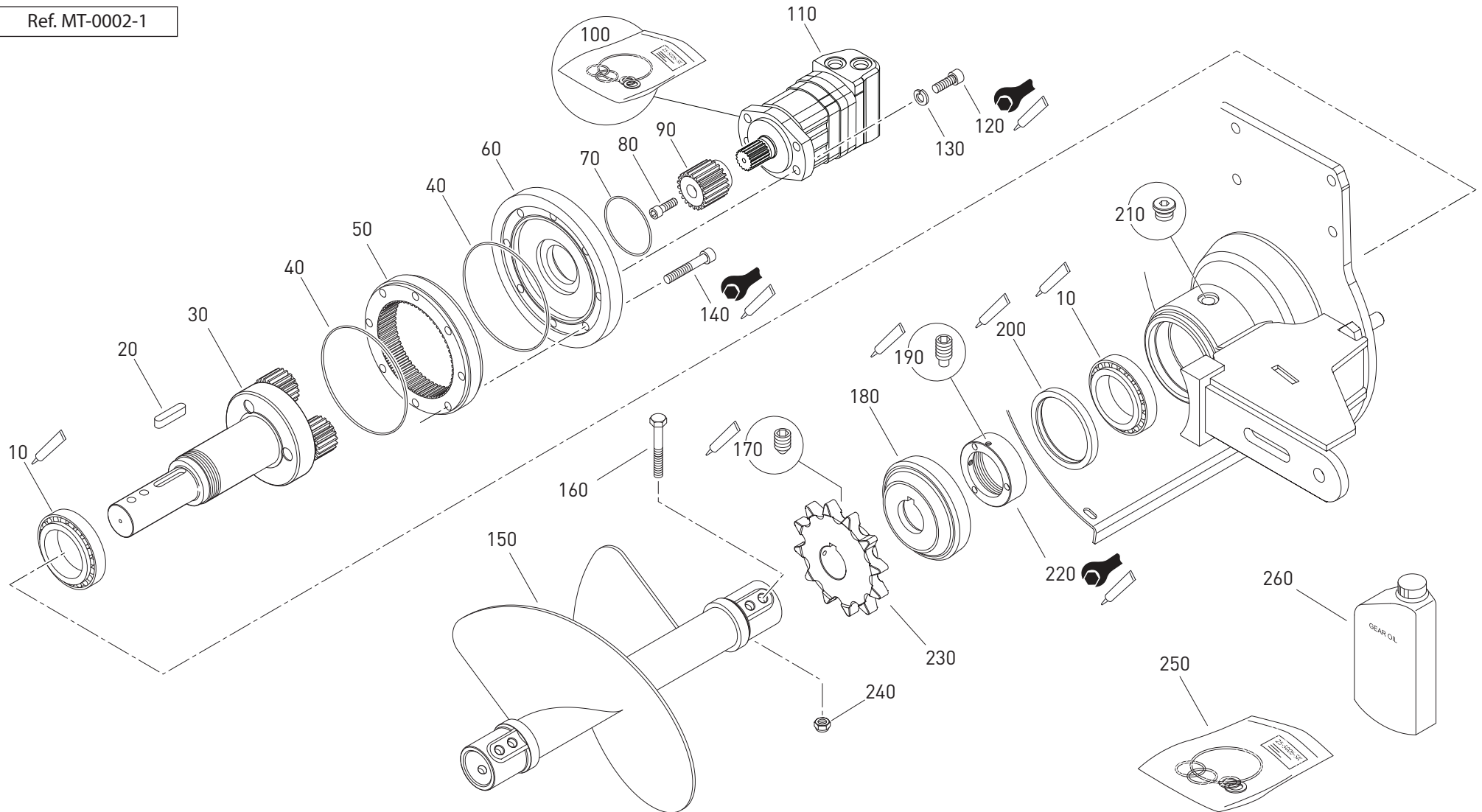

MT600 - MT900 Trencher - Parts List

MT900 from Serial Number 450920004

ITEM	PART NO.	DESCRIPTION	QTY	TORQUE LOAD	THREAD TREATMENT	NOTES
10	99-1104	● TAPER BEARING 75mm (32015X)	2		LOCTITE 7471, 641	
20	42-1027	● KEY-DRIVE SHAFT - ALL TRENCHERS	1			
30	21-3913	● TRENCHER SHAFT ASSEMBLY - 3.86:1	1			
40	99-1532-V	●○ O'RING - 162 x 3.0 (SERIES 3 RING)	2			See Seal Kit
50	21-3004	● RING GEAR - 60T - 2.5 MOD.	1			
60	21-3057	● BTM INPUT - TRENCHER DIR. SUN GEAR	1			
70	99-1540-V	●○ O'RING - 86 ID x 2.5 DIAMETER (Motor seal)	1			See Seal Kit
80	99-9633-100	● FIXING - 3/8" UNC X 1" LONG SOCKET CAP SCREW - BLACK	1			
90	21-3049	● SUN GEAR - 21T - MOTOR MTG.	1			
100	25-2312	● SEAL KIT - MOTOR	1			
110	25-2303	● MOTOR - ATE 80cc - 14T SHAFT	1			
120	99-9135-035	● FIXING - M12 x 35 SOCKET CAP SCREW (12.9 Grade)	4	121 - 135 Nm	LOCTITE 243	
130	99-9165	● FIXING - M12 SPRING WASHER	4			
140	99-9135-075	● FIXING - M12 x 75 SOCKET CAP SCREW (12.9 Grade)	8	121 - 135 Nm	LOCTITE 243	
150	42-1921	● AUGER - DUAL HUB	1			
160	99-9115-090	● FIXING - BOLT - M12 x 90 - BOLT (10.9 Grade)	2			
170	99-9223-010	● SETSCREW -CONE PT- M8 x 10	2		LOCTITE 243	
180	42-1103	● SEAL PROTECTOR (70 Bearing output housing)	1			
190	99-9213-012	● GRUB SCREW - M8X12 SQUARE POINT (14.9 Grade)	2		LOCTITE 243	
200	99-1504	●○ OIL LIP SEAL - (100 x120 x12)	1		LOCTITE 7471, 515	See Seal Kit
210	21-5071	● 1/2" BSP MAGNETIC PRESSURE PLUG	2			
220	21-3019	● LOCKING NUT M75	1	350 Nm	LOCTITE 209125	
230	42-1096	● SPROCKET - C/W Collar (MINI-T)	1			
240	99-9185	● FIXING - NUT NYLOC M12 (8.8 Grade)	2			
250	SK-21-390	● SEAL KIT - GEARBOX - SERIES 3 - Comprising of items 40,70 &190	1			
260	99-8101	● GEAR OIL - EP320 - MINERAL (1 Litre Bottle) All units are supplied with 320 viscosity oil, except where the unit is to be or stored in extreme temperatures.	2			1100 ml required
	99-8104	● GEAR OIL - EP150 - MINERAL When using or storing the units below -15°C				
	99-8106	● GEAR OIL - EP460 - MINERAL When using or storing the units above 35°C				
	21-3999-2K	● KIT - DRIVE SUB ASSY - Comprising of items 10 to 80, 110 to 130 & 160 to 220	1			Ref. MT-0002-1

MT600 - MT900 Trencher - Parts List

MT900 from Serial Number 450920001

Ref. MT-0003-1

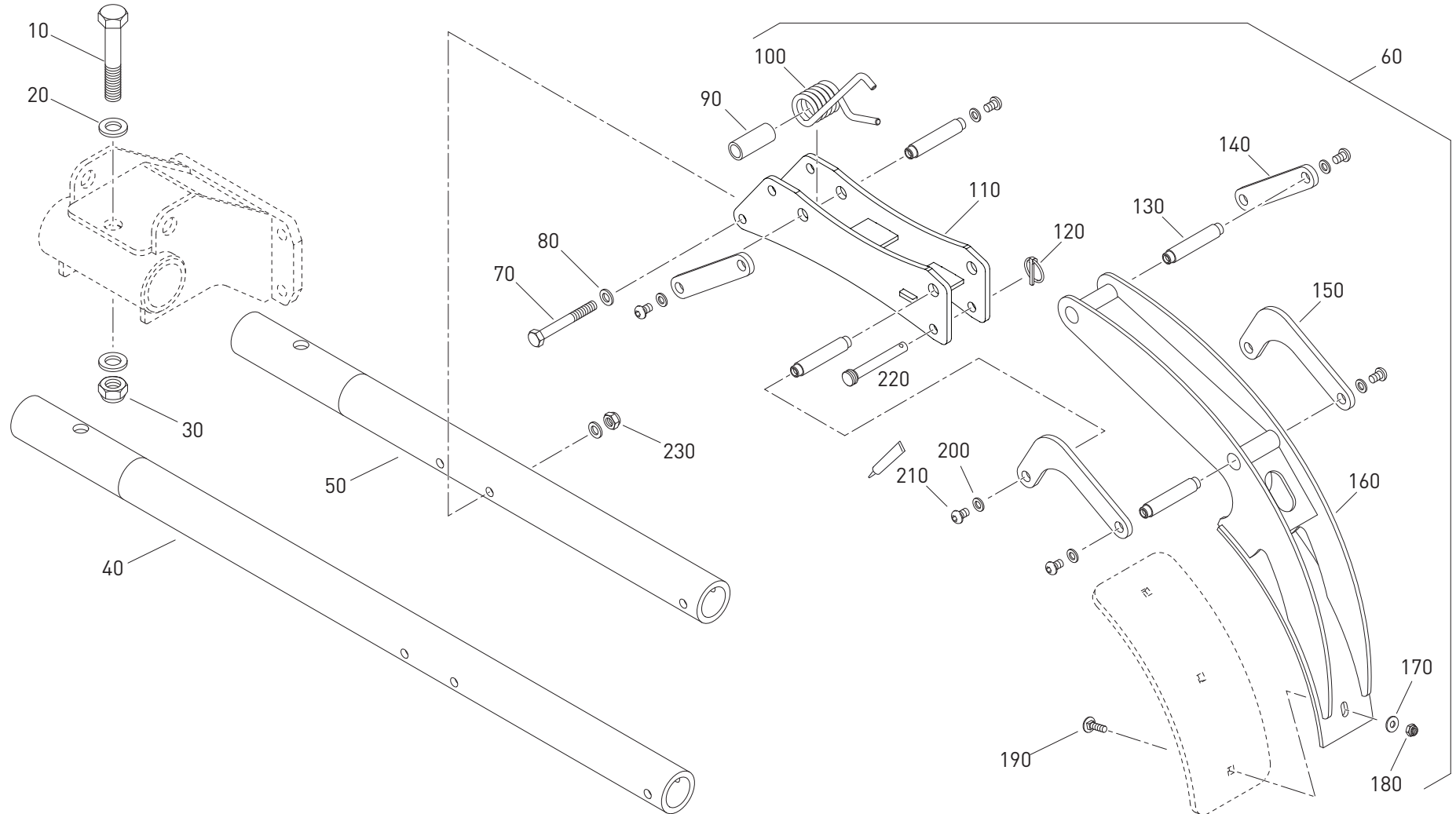

MT600 - MT900 Trencher - Parts List

MT900 from Serial Number 450920004

ITEM	PART NO.	DESCRIPTION	QTY	TORQUE LOAD	THREAD TREATMENT	NOTES
10	99-9117-120	• FIXING - BOLT M20 X 2.5 X 120 LONG (8.8 Grade)	1			
20	99-9157	• FIXING - M20 PLAIN WASHER	2			
30	99-9187	• FIXING - M20 METRIC NYCLOC NUT (8.8 Grade)	1			
40	45-1025	• DANGER BAR TUBE - (MT900)	1			
50	45-1024	• DANGER BAR TUBE - (MT600)	1			
60	45-1909	• TRENCH CLEANER ASSEMBLY	1			
70	99-9115-100	• FIXING - BOLT - M12 x 100	1			
80	99-9155	• FIXING - WASHER - M12	2			
90	42-1056	• TUBE - SPRING BUSH	1			
100	43-1102	• SPRING - TRENCHER CLEANER	1			
110	45-1902	• TRENCH CLEANER- PIVOT FAB	1			
120	99-99021	• LINCH PIN - 3545 - 4.5 x 28 x 35	1			
130	42-1045	• PIN - LINK PIVOT TAPPED	4			
140	42-1046	• LINK PLATE - SHORT	2			
150	42-1047	• PLATE - LONG LINK	2			
160	42-1913	• MAIN ARM FAB. (TRENCHER CLEANER)	1			
170	99-9154-P	• FIXING - M10 PLAIN "PENNY" WASHER	3			
180	99-9184	• FIXING - M10 METRIC NYLOC NUT	3			
190	99-9204-035	• FIXING - COACH BOLT M10 X 35 LG	3			
200	99-9154	• FIXING - M10 PLAN WASHER	8			
210	99-9254-16	• FIXING - M10 x 16 SKT HD BUTTON SETSCREW	8		LOCTITE 243	
220	42-1055	• PIN - AUGER RETAINER	1			
230	99-9185	• FIXING - M12 METRIC NYLOC NUT (8.8 Grade)	1			
						Ref. MT-0003-1

MT600 - MT900 Trencher - Parts List

MT900 from Serial Number 450920001

Ref. MT-0004-1

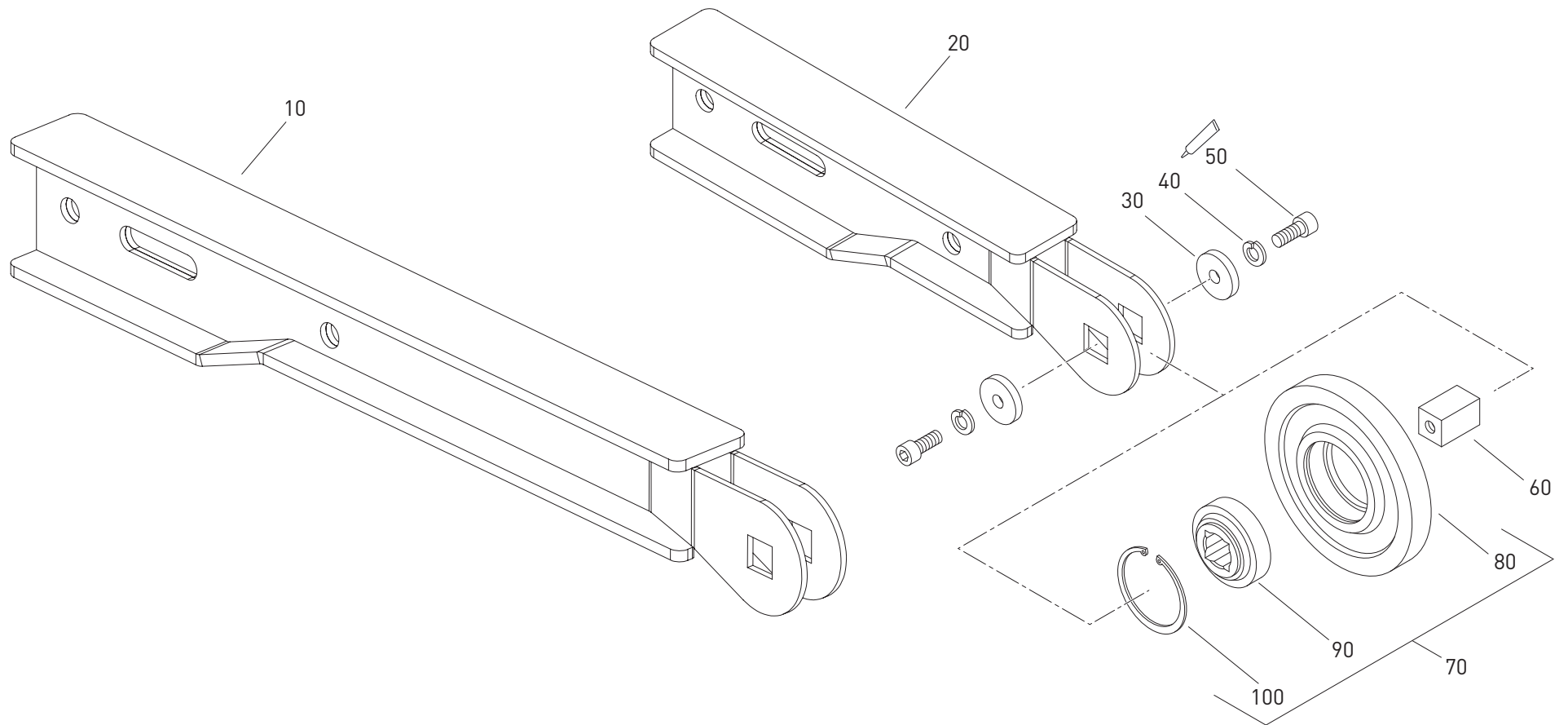

MT600 - MT900 Trencher - Parts List

MT900 from Serial Number 450920001

ITEM	PART NO.	DESCRIPTION	QTY	TORQUE LOAD	THREAD TREATMENT	NOTES
10	42-1929	• BOOM WELD ASSY (MT900)	1			
20	42-1930	• BOOM WELD ASSY (MT600)	1			
30	42-1024	• WASHER - TRENCHER BOOM NOSE	2			
40	99-9165	• FIXING - SPRING WASHER - M12 H/D	2			
50	99-9135-030	• FIXING - SKT HD CAP M12 x 30	2		LOCTITE 243	
60	42-1025	• PIN SQUARE - NOSE ROLLER (INC MAT'L)	1			
70	42-1900	• NOSE ROLLER ASSY	1			
80	42-1026	• ROLLER - BOOM NOSE	1			
90	99-1207	• BEARING - TRENCHER NOSE ROLLER (W208PP5)	1			
100	99-1603	• CIRCLIP - INTERNAL - NOSE ROLLER- 80mm INT.	1			
						Ref. MT-0004-1

MT600 - MT900 Trencher - Parts List

MT900 from Serial Number 45092000+

Ref. MT-0005-1

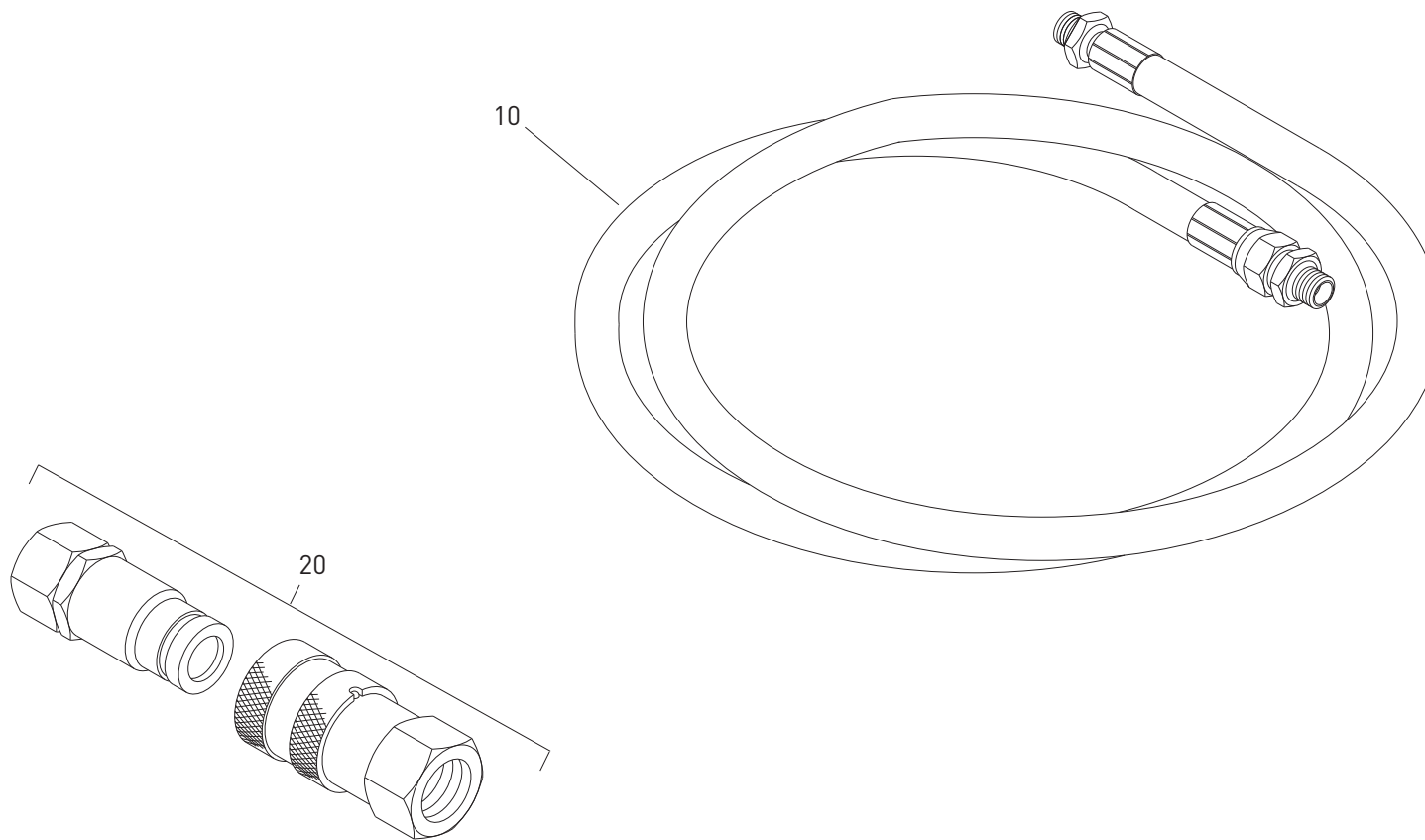

MT600 - MT900 Trencher - Parts List

MT900 from Serial Number 450920001

ITEM	PART NO.	DESCRIPTION	QTY	TORQUE LOAD	THREADLOCKER	NOTES
10	99-7504	<ul style="list-style-type: none"> HOSE - 1.8M 1/2" BSP Str/Str 	2			
20	99-7052-M/F	<ul style="list-style-type: none"> QRC'S - 1/2" FF <p>Note: QRC's not available in all regions</p>	1			
						Ref. MT-0005-1

MT600 - MT900 Trencher - Parts List

MT900 from Serial Number 450920001

Ref. MT-0006-1

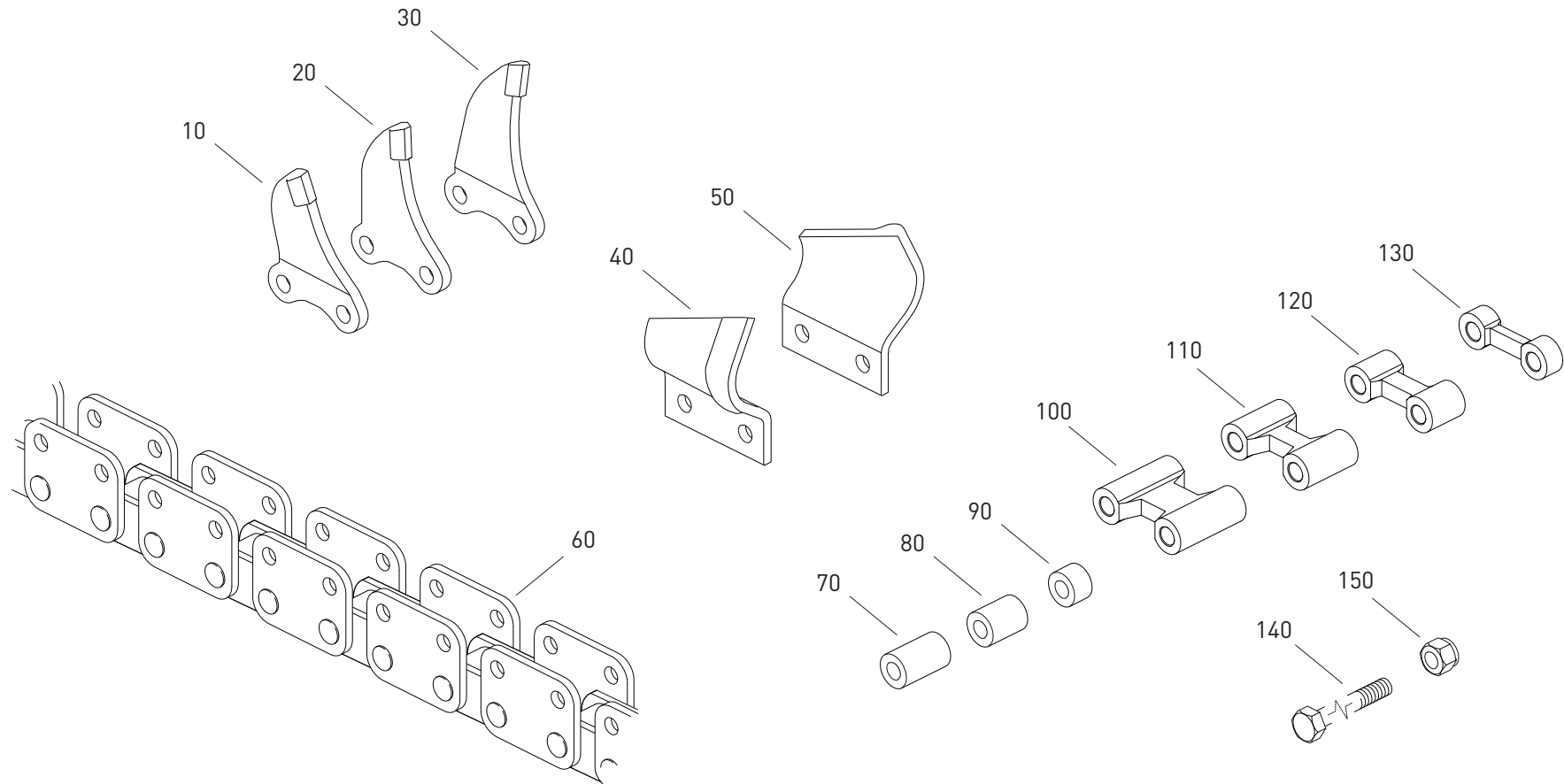

MT600 - MT900 Trencher - Parts List

MT900 from Serial Number 450920004

ITEM	PART NO.	DESCRIPTION	QTY	TORQUE LOAD	THREAD TREATMENT	NOTES
10	44-2003	• TOOTH - MINI-T RIGHT HAND TUNGSTEN	1			
20	44-2002	• TOOTH - MINI-T CENTRE TUNGSTEN	1			
30	44-2001	• TOOTH - MINI-T LEFT HAND TUNGSTEN	1			
40	44-2011	• TOOTH - MINI-T RIGHT HAND EARTH	1			
50	44-2010	• TOOTH - MINI-T LEFT HAND EARTH	1			
60	44-2026	• CHAIN - 48 LINKS (600 DEEP)	1			
	44-2025	• CHAIN - 64 LINKS (900 DEEP)	1			
70	44-2027	• CHAIN SPACER - 38.5 LONG	1			
80	44-2028	• CHAIN SPACER - 30.0 LONG	1			
90	44-2029	• CHAIN SPACER - 15.3 LONG	1			
100	44-2034	• SPACER BLOCK - 50mm WIDE	1			
110	44-2033	• SPACER BLOCK - 37.5mm WIDE	1			
120	44-2032	• SPACER BLOCK - 25mm WIDE	1			
130	44-2031	• SPACER BLOCK - 12mm WIDE	1			
140	99-9124-025	• FIXING - SETSCREW - M10 x 25mm	1			
	99-9124-030	• FIXING - SETSCREW - M10 x 30mm	1			
	99-9114-040	• FIXING - BOLT - M10 x 40mm	1			
	99-9114-050	• FIXING - BOLT - M10 x 50mm	1			
	99-9114-055	• FIXING - BOLT - M10 x 55mm	1			
	99-9114-060	• FIXING - BOLT - M10 x 60mm	1			
	99-9114-065	• FIXING - BOLT - M10 x 65mm	1			
	99-9114-070	• FIXING - BOLT - M10 x 70mm	1			
	99-9114-075	• FIXING - BOLT - M10 x 75mm	1			
	99-9114-080	• FIXING - BOLT - M10 x 80mm	1			
	99-9114-090	• FIXING - BOLT - M10 x 90mm	1			
	99-9114-100	• FIXING - BOLT - M10 x 100mm	1			
	99-9114-110	• FIXING - BOLT - M10 x 110mm	1			
	99-9114-120	• FIXING - BOLT - M10 x 120mm	1			
	99-9114-200	• FIXING - BOLT - M10 x 200mm	1			
	99-9114-210	• FIXING - BOLT - M10 x 210mm	1			
	99-9114-230	• FIXING - BOLT - M10 x 230mm	1			
	99-9114-250	• FIXING - BOLT - M10 x 250mm	1			
	99-9114-260	• FIXING - BOLT - M10 x 260mm	1			
	99-9114-280	• FIXING - BOLT - M10 x 280mm	1			
	99-9114-290	• FIXING - BOLT - M10 x 290mm	1			
150	99-9184	• FIXING - NUT NYLOC M10	1			

Ref. MT-0006-1

MT600 - MT900 Trencher - Parts List

MT900 from Serial Number 450920001

Ref. MT-0007-1

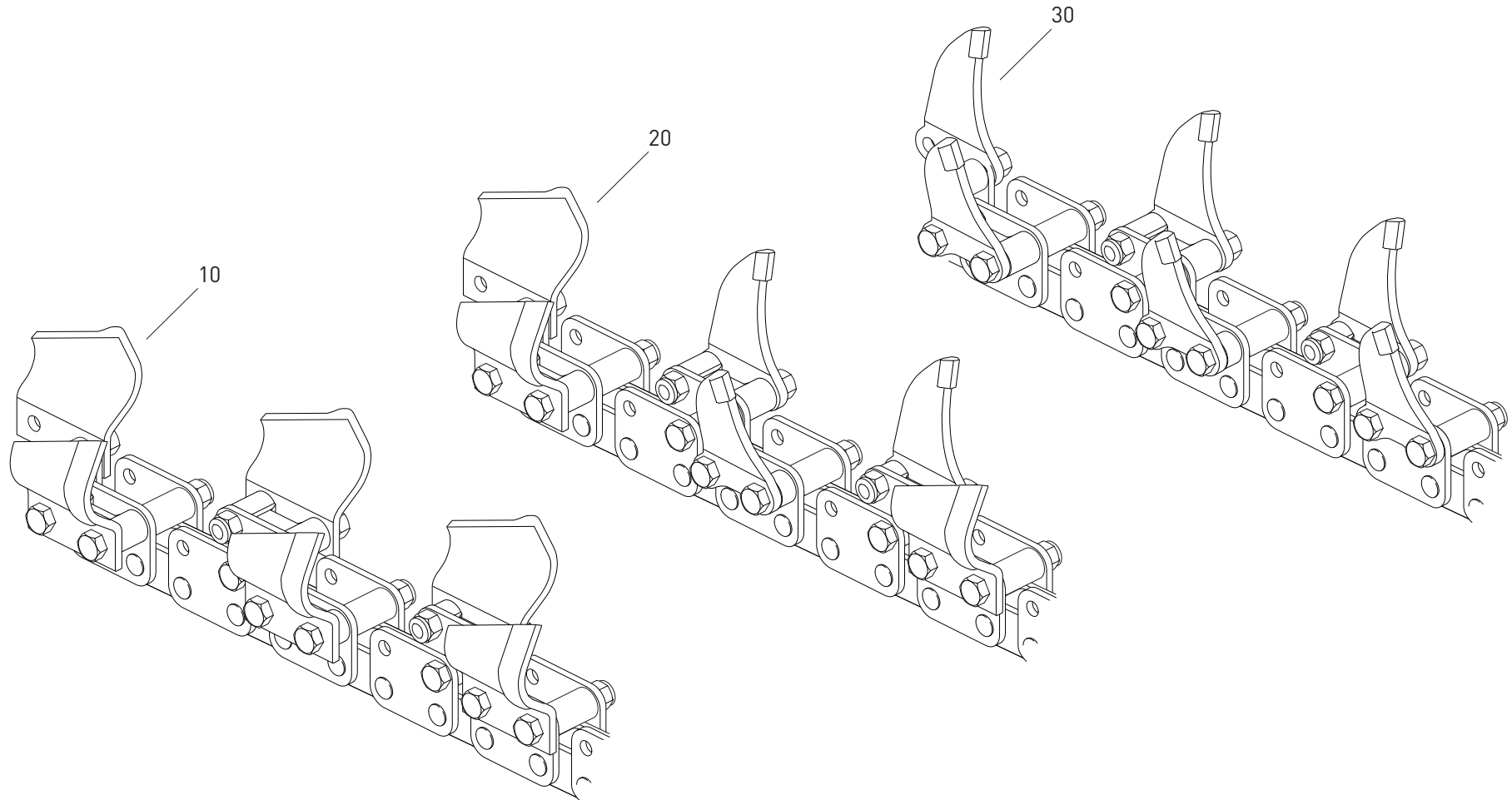

MT600 - MT900 Trencher - Parts List

MT900 from Serial Number 450920004

ITEM	PART NO.	DESCRIPTION	QTY	TORQUE LOAD	THREAD TREATMENT	NOTES
10	44-2901	● CHAIN - 600 x 100 EARTH	1			
	44-2903	● CHAIN - 600 x 150 EARTH	1			
	44-2905	● CHAIN - 600 x 200 EARTH	1			
	44-2907	● CHAIN - 900 x 100 EARTH	1			
	44-2909	● CHAIN - 900 x 150 EARTH	1			
	44-2911	● CHAIN - 900 x 200 EARTH	1			
	44-2939	● CHAIN - 900 x 250 EARTH	1			
	44-2933	● CHAIN - 900 x 300 EARTH	1			
20	44-2902	● CHAIN - 600 x 100 COMBI	1			
	44-2904	● CHAIN - 600 x 150 COMBI	1			
	44-2906	● CHAIN - 600 x 200 COMBI	1			
	44-2908	● CHAIN - 900 x 100 COMBI	1			
	44-2910	● CHAIN - 900 x 150 COMBI	1			
	44-2912	● CHAIN - 900 x 200 COMBI	1			
	44-2915	● CHAIN - 900 x 250 COMBI	1			
	44-2934	● CHAIN - 900 x 300 COMBI	1			
30	44-2918	● CHAIN - 600 x 100 TUNGSTEN	1			
	44-2913	● CHAIN - 600 x 150 TUNGSTEN	1			
	44-2914	● CHAIN - 600 x 200 TUNGSTEN	1			
	44-2916	● CHAIN - 900 x 100 TUNGSTEN	1			
	44-2920	● CHAIN - 900 x 150 TUNGSTEN	1			
	44-2921	● CHAIN - 900 x 200 TUNGSTEN	1			
	44-2941	● CHAIN - 900 x 250 TUNGSTEN	1			
	44-2935	● CHAIN - 900 x 300 TUNGSTEN	1			
						Ref. MT-0007-1

MT600 - MT900 Trencher - Parts List

MT900 from Serial Number 450920001

Ref. MT-0008-1

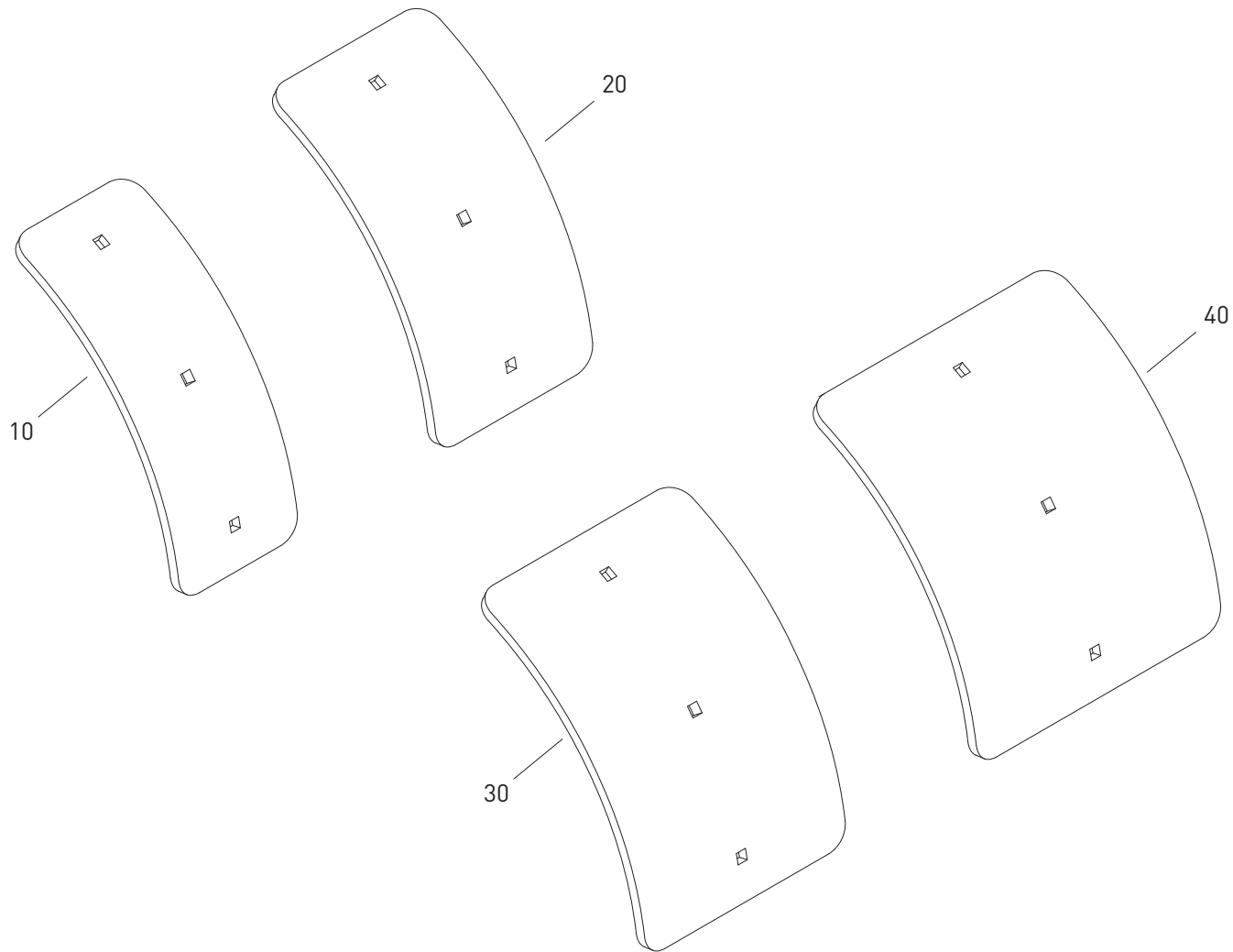

MT600 - MT900 Trencher - Parts List

MT900 from Serial Number 450920001

ITEM	PART NO.	DESCRIPTION	QTY	TORQUE LOAD	THREAD TREATMENT	NOTES
10	42-1058	• SCRAPER - MT - 332 x 130 FOR 150MM CHAINS	1			
20	42-1030	• SCRAPER - MT - 332 x 180 FOR 200MM CHAINS	1			
30	42-1052	• SCRAPER - MT - 332 x 230 FOR 250MM CHAINS	1			
40	42-1057	• SCRAPER - MT - 332 x 280 FOR 300MM CHAINS	1			
						Ref. MT-0008-1



PO Box 982
Alexandria, MN 56308
Toll Free: 877-378-4642
www.skidpro.com

SKID PRO ATTACHMENT WARRANTY

Attachments covered under this 24 Month Warranty include:

Skid Pro warrants above attachments for twenty-four months from date of shipment, to the original owner. Warranty covers products to be free from defects in material and workmanship when properly set up and operated in accordance with Skid Pro's recommendations.

WARRANTY CLAIM PROCEDURE

All warranty claims must be submitted within the manufacturer's limited warranty period. Pictures and/or a video of the failing component(s) are required to properly document all potential warranty claims. To submit a warranty claim, contact your Skid Pro Product Guru or complete a [Warranty Claim Form](#) on our website and send it along with supporting pictures/video to sales@skidpro.com. Upon receipt, the warranty claim information will be reviewed and once determined to be a valid claim, a return authorization number will be issued for the return of the defective part(s) if applicable and replacement part(s) will be shipped. If it is determined the defective parts are to be returned and they are not received by Skid Pro within 30 days of receiving the replacement parts, the Buyer will be charged for the cost of the replacement parts plus any shipping charges. Tampering with the failed part (i.e. disassembling a motor or cylinder) will void the warranty.

EXCLUSIONS OF WARRANTY

Skid Pro's requirement for any issue with respect to attachments shall be limited to repairing or replacing the defective part, as this is a parts-only warranty and does not include any labor to replace or install the part or downtime from resulting issue. Skid Pro has full technical support & assistance to assure customer replaces the part properly for optimal performance on attachment.

This warranty shall not apply to any attachment's wear items, or attachments that have been repaired or altered outside the Skid Pro factory in any way, or that has been subject to misuse, negligence or accident beyond Skid Pro's recommended use and/or machine rated capacity.

This warranty is exclusive and in lieu of all other warranties and conditions. Skid Pro disclaims all other warranties and conditions, express or implied, including any implied warranties or conditions of merchantability or fitness for a particular purpose. In no event shall Skid Pro be liable for any special, incidental, indirect or consequential damage, whatsoever, including, but not limited to, loss or interruption of business, lost profits, or loss of machine use, whether based on contract, warranty, tort, negligence, strict liability, statute or otherwise, even if Skid Pro has been advised of the possibility of such damages.

No agent, employee, or representative of Skid Pro has any authority to bind said company to any affirmation, representation, or warranty concerning its machinery and/or attachments except as specifically set forth herein. Any disagreement or dispute of warranty policy or customer expectations of product, soundness, functionality, or performance would take place in Douglas County, Alexandria, MN, where Skid Pro operates.