

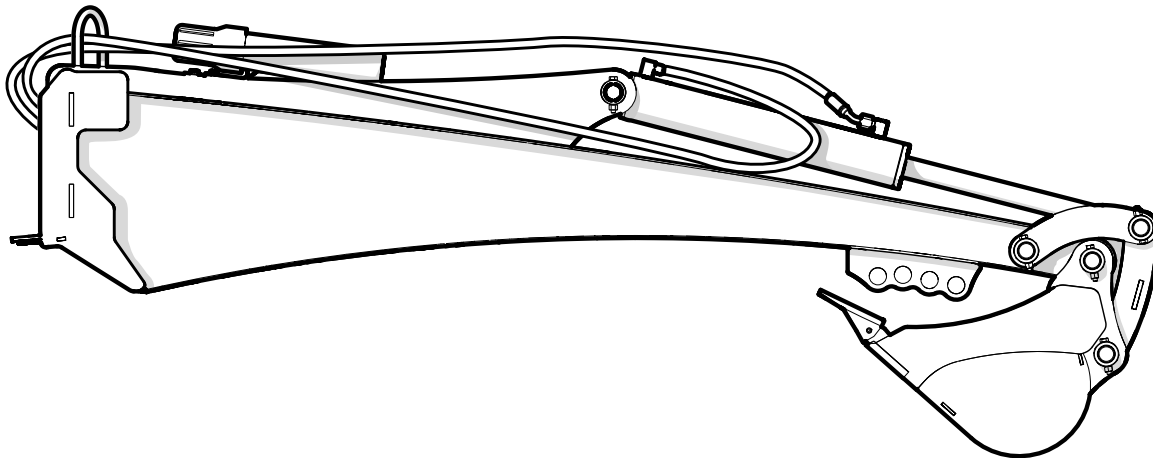

Serial Number 3605Q2 & up

PARTS MANUAL

QC605 / B MINI SKID STEER BACK HOE



Foreword

This Wallenstein parts manual is prepared to assist customers in ordering quality OEM replacement parts.

Regular maintenance combined with replacing old, worn or broken parts with the correct OEM parts is essential in prolonging the life of your Wallenstein product. Refer to this manual to identify replacement parts.

To order parts, contact your Wallenstein dealer or distributor. Have the product model and serial number handy.

All information contained in this parts manual is current as per the revision date at the bottom of the page. Wallenstein reserves the right to change product specifications at any time without notice.

If your product specifications differ from those contained in this manual, contact Wallenstein for current information.

Reproduction of information in this parts manual is prohibited without prior written permission from Wallenstein Equipment Inc.

Wallenstein Equipment Inc. • © 2019

WARNING!

Refer to the operators manual for safe operation and maintenance.

Maintenance should be performed by trained personnel only.

Serial Number Location

Always provide the model and serial number of your Wallenstein product when ordering parts or requesting service or other information. This information is found on the product information plate as shown below.

Record your product information here for future reference.

Model _____

Serial Number _____

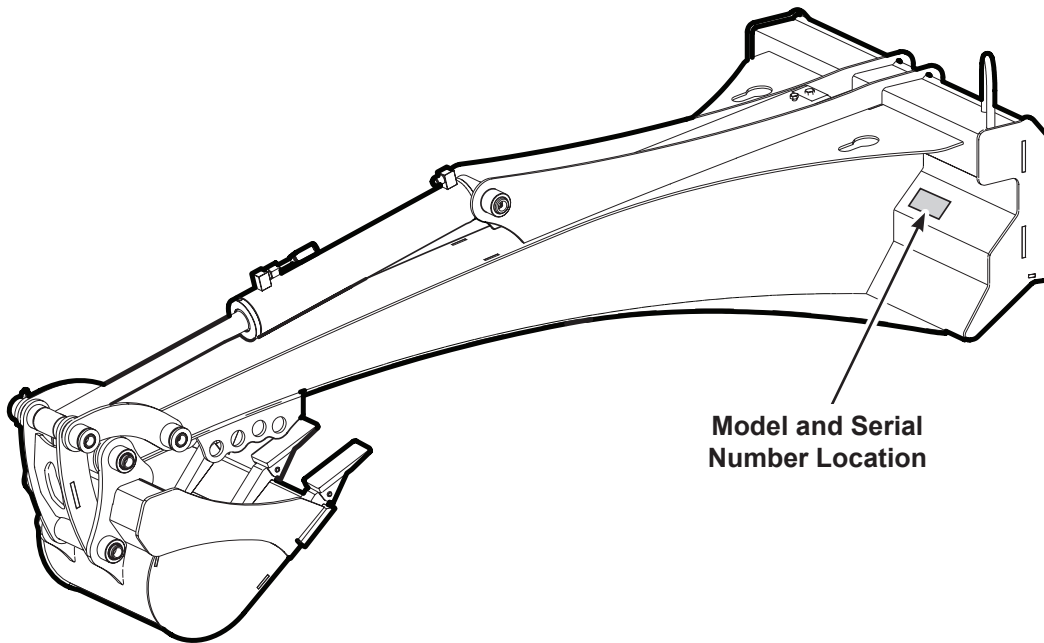

Model and Serial Number Location

Contents

Main Frame Assembly - QC605.....	4
Main Frame Assembly - QC605B	5
Bucket and Linkage Assembly	6
Mechanical Thumb Assembly	7
Cylinder Detail	8
Hydraulic Circuit	8
Decal Layout.....	9
Common Bolt Torque Values	10
Hydraulic Fitting Torque Values	11

Main Frame Assembly – QC605

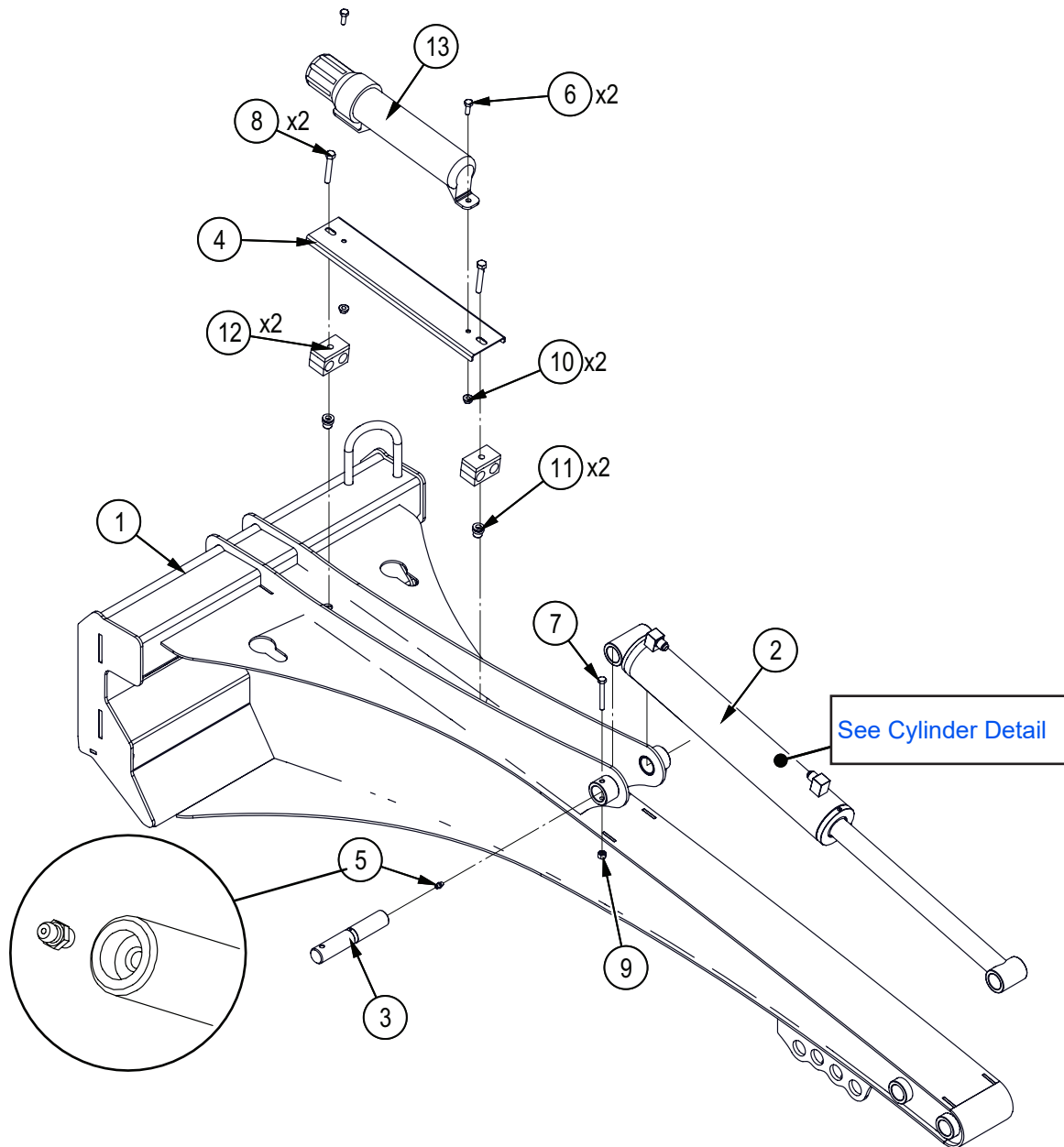

Item No.	Part No.	Description	Qty
1	3033W500	Main Frame & Boom	1
2	3011C107	Cylinder, 2-1/4 x 12-7/8" Stroke	1
3	3011M110	Pin, 1" x 5.66 Greasable	1
4	3033L515	Manual Tube Mount	1
5	Z29202	Grease Fitting, 1/4NF	1
6	Z71107	Hex Bolt 1/4NC x 3/4	2
7	Z71120	Hex Bolt, 1/4NC x 2"	1
8	Z71220	Hex Bolt 5/16NC x 2	2
9	Z72211	Hex Lock Nut 1/4NC	1
10	Z72511	Serrated Flange Locknut, 1/4NC	2
11	Z72956	Rivet Nut, 5/16NC x 150	2
12	Z79463	Double Hose Clamp, 1 1/16" OD	2
13	Z96505	Manual Tube, 2" Short	1

Main Frame Assembly – QC605B

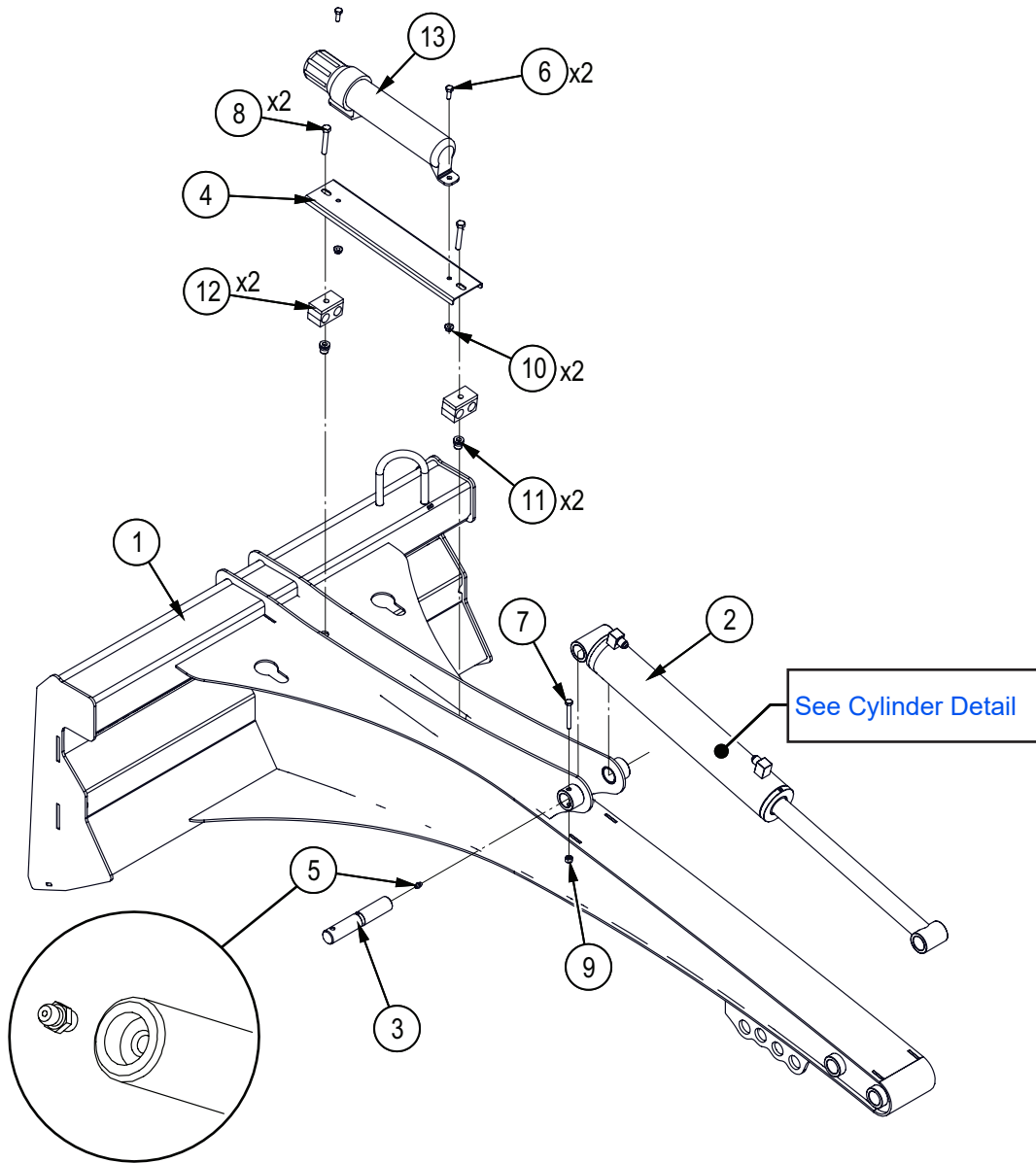

Item No.	Part No.	Description	Qty
1	3033W750	Main Frame & Boom	1
2	3011C107	Cylinder, 2-1/4 x 12-7/8" Stroke	1
3	3011M110	Pin, 1" x 5.66 Greasable	1
4	3033L515	Manual Tube Mount	1
5	Z29202	Grease Fitting, 1/4NF	1
6	Z71107	Hex Bolt 1/4NC x 3/4	2
7	Z71120	Hex Bolt, 1/4NC x 2"	1
8	Z71220	Hex Bolt 5/16NC x 2	2
9	Z72211	Hex Lock Nut 1/4NC	1
10	Z72511	Serrated Flange Locknut, 1/4NC	2
11	Z72956	Rivet Nut, 5/16NC x 150	2
12	Z79463	Double Hose Clamp, 11/16" OD	2
13	Z96505	Manual Tube, 2" Short	1

Bucket and Linkage Assembly

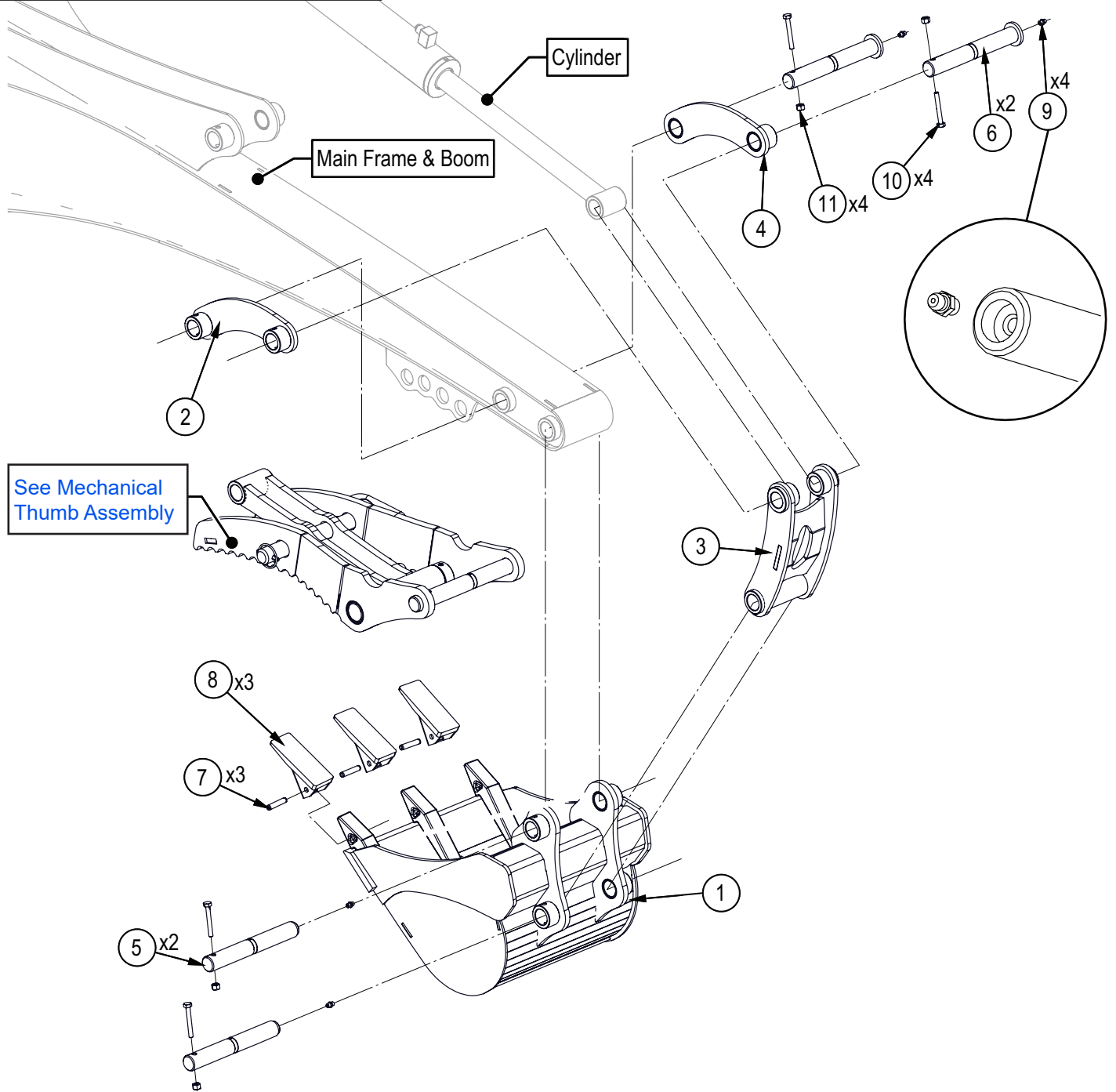

Item No.	Part No.	Description	Qty
1	3082W011	12" Small Bucket	1
2	3011W102	RH Bucket Linkage	1
3	3011W103	Middle Bucket Linkage	1
4	3011W119	LH Bucket Linkage	1
5	3011M109	Pin, 1 x 7.45 Greasable	2
6	3011W117	Bucket Pin w/ Washer	2
7	Z14181	Roll Pin, 5/16" x 1-1/2"	3
8	Z19902	Tooth, Backhoe Pin-on	3
9	Z29202	Grease Fitting, 1/4NF	4
10	Z71120	Hex Bolt, 1/4NC x 2"	4
11	Z72211	Hex Lock Nut 1/4NC	4

Mechanical Thumb Assembly

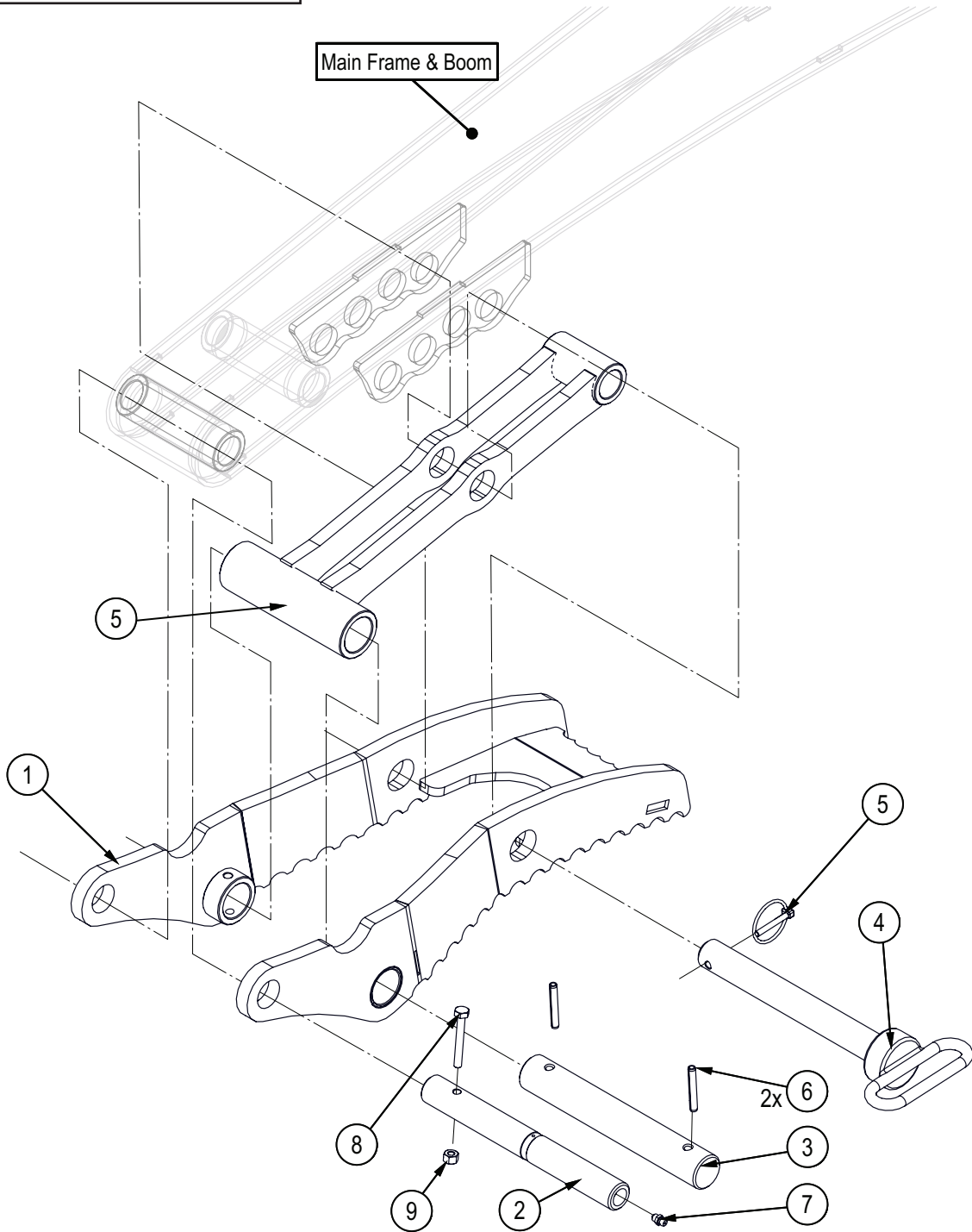

Item No.	Part No.	Description	Qty
1	3083W161	Thumb	1
2	3083M064	Pin, Extended Bucket - Thumb	1
3	3083M161	Pin, Thumb Brace Pivot	1
4	Z11263	Hitch Pin, 1" x 7-1/2"	1
5	Z12110	Lynch Pin, 3/16"	1
6	Z14172	Roll Pin, 1/4" x 1-3/4"	2
7	Z29202	Grease Fitting, 1/4NF	1
8	Z71120	Hex Bolt, 1/4NC x 2"	1
9	Z72211	Hex Lock Nut 1/4NC	1
10	3083W162	Link, Thumb Support	1

Cylinder Detail

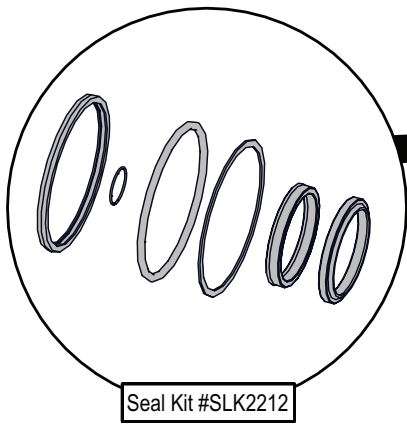

Seal Kit #SLK2212

Item No.	Part No.	Description	Qty
1	3011C1073	Rod, 1-1/4 x 3/4	1
2	3011C1074	Barrel, 2-1/4" Bore	1
3	G225-125S	Gland, 2-1/4" x 1-1/4"	1
4	P750-225SP	Piston, 2-1/4" Bore	1
5	Z72276	Hex Lock Nut, 3/4NF GR8	1

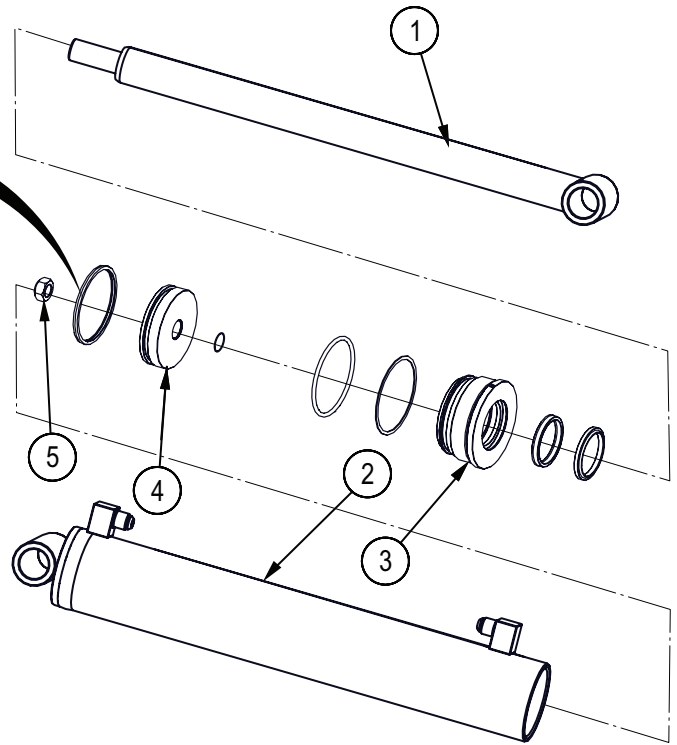

Hydraulic Circuit

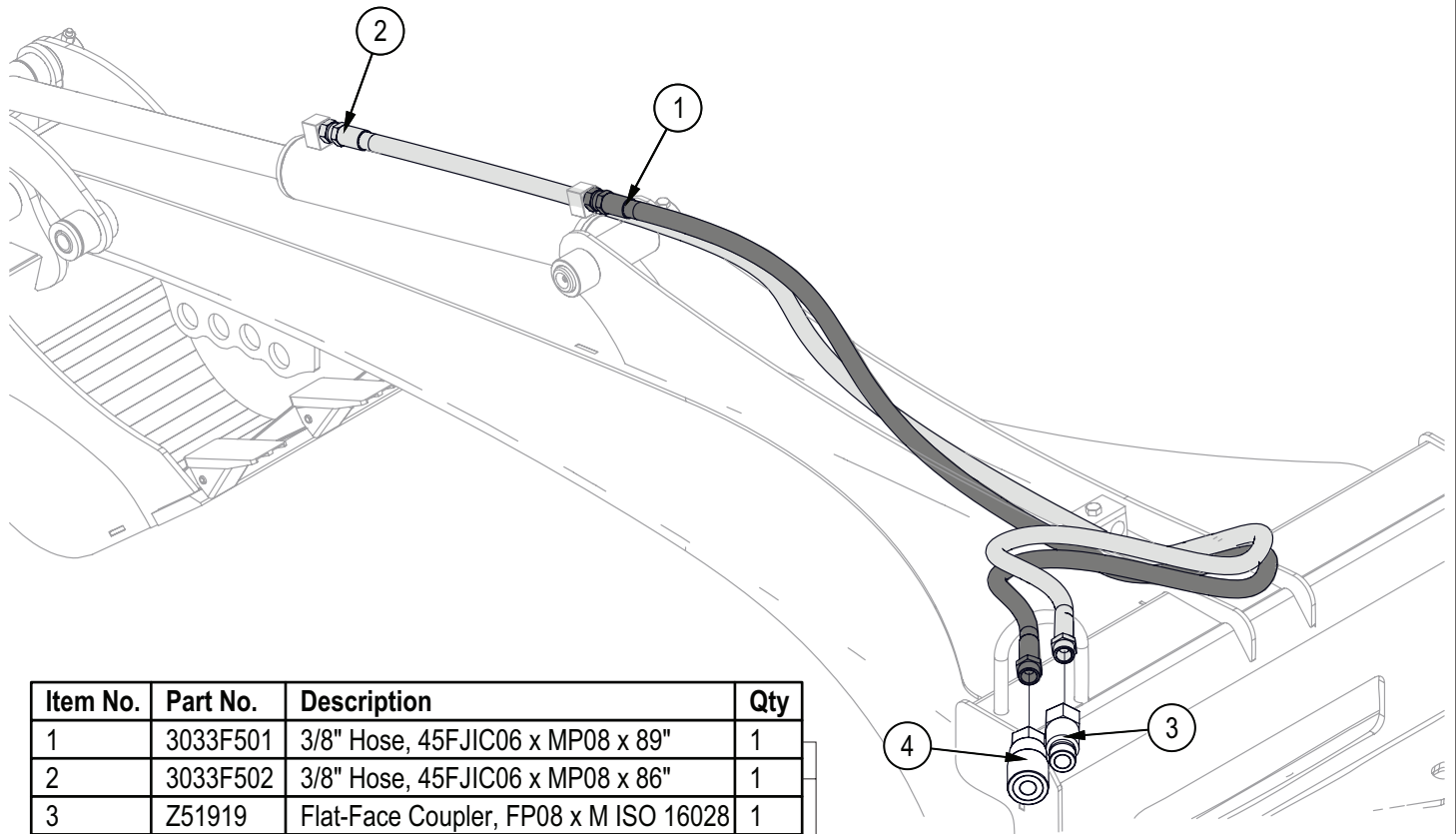

Item No.	Part No.	Description	Qty
1	3033F501	3/8" Hose, 45FJIC06 x MP08 x 89"	1
2	3033F502	3/8" Hose, 45FJIC06 x MP08 x 86"	1
3	Z51919	Flat-Face Coupler, FP08 x M ISO 16028	1
4	Z51920	Flat-Face Coupler, FP08 x F ISO 16028	1

ECR03787

Decal Layout

IMPORTANT! If parts are replaced that have safety signs on them, new signs must be applied. Safety signs must always be replaced if they become damaged, are removed, or become illegible.

Safety signs are included in the product decal kit available from your authorized dealer. Decals are not available separately.

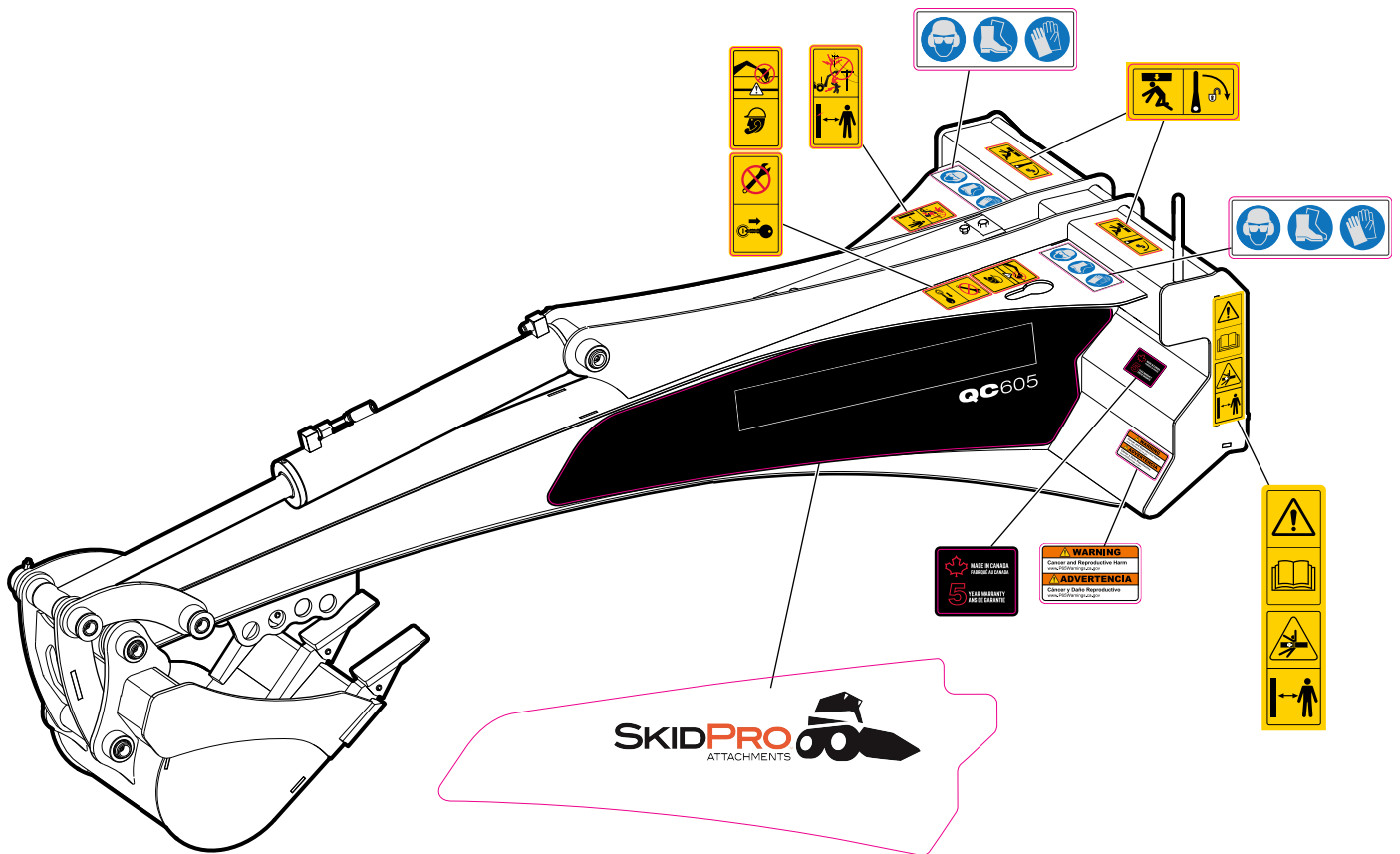

Common Bolt Torque Values

Checking Bolt Torque

The tables shown give correct torque values for various bolts and capscrews. Tighten all bolts to the torque values specified in the table, unless indicated otherwise. Check tightness of bolts periodically.

IMPORTANT! If replacing hardware, use fasteners of the same grade.

IMPORTANT! Torque figures indicated in the table are for non-greased or non-oiled threads. Do not grease or oil threads unless indicated otherwise. When using a thread locker, increase torque values by 5%.

 **NOTE:** Bolt grades are identified by their head markings.

Imperial Bolt Torque Specifications

Bolt Diameter	Torque Value					
	SAE Gr. 2		SAE Gr. 5		SAE Gr. 8	
	lbf•ft	N•m	lbf•ft	N•m	lbf•ft	N•m
1/4"	6	8	9	12	12	17
5/16"	10	13	19	25	27	36
3/8"	20	27	33	45	45	63
7/16"	30	41	53	72	75	100
1/2"	45	61	80	110	115	155
9/16"	60	95	115	155	165	220
5/8"	95	128	160	215	220	305
3/4"	165	225	290	390	400	540
7/8"	170	230	420	570	650	880
1"	225	345	630	850	970	1320



SAE Gr. 2



SAE Gr. 5



SAE Gr. 8

Metric Bolt Torque Specifications

Bolt Diameter	Torque Value			
	Gr. 8.8		Gr. 10.9	
	lbf•ft	N•m	lbf•ft	N•m
M3	0.4	0.5	1.3	1.8
M4	2.2	3	3.3	4.5
M6	7	10	11	15
M8	18	25	26	35
M10	37	50	52	70
M12	66	90	92	125
M14	83	112	116	158
M16	166	225	229	310
M20	321	435	450	610
M30	1,103	1 495	1,550	2 100



8.8



10.9

Hydraulic Fitting Torque Values

Tightening Flare Type Tube Fittings

1. Check flare and flare seat for defects that might cause leakage.
2. Align tube with fitting before tightening.
3. Hand-tighten swivel nut until snug.
4. To prevent twisting the tube, use two wrenches. Place one wrench on the connector body and tighten the swivel nut with the second. Torque to values shown.

If a torque wrench is not available, use the FFFT (Flats From Finger Tight) method.

Hydraulic Fitting Torque					
Tube Size OD	Hex Size Across Flats	Torque value		Flats From Finger Tight	
		lbf•ft	N•m	Flats	Turns
3/16	7/16	6	8	2	1/6
1/4	9/16	11–12	15–17	2	1/6
5/16	5/8	14–16	19–22	2	1/6
3/8	11/16	20–22	27–30	1-1/4	1/6
1/2	7/8	44–48	59–65	1	1/6
5/8	1	50–58	68–79	1	1/6
3/4	1-1/4	79–88	107–119	1	1/8
1	1-5/8	117–125	158–170	1	1/8

Values shown are for non-lubricated connections.