



Landscape Rake

Operation and Maintenance Manual



Revision Date: March 2025

Skid Pro Attachments

PO Box 982
Alexandria, MN 56308
Toll Free: 877-378-4642

www.skidpro.com

Contents

INTRODUCTION.....	2
To the Purchaser	2
Illustrations.....	2
Direction Reference	2
Serial Plate.....	2
SAFETY PRECAUTIONS	3
Children.....	3
Safety Precautions – Landscape Rake	4
Safety Notices	4
Modifications to Equipment.....	4
ABOUT THE Landscape Rake ATTACHMENT	5
Attaching the Landscape Rake to the Carrier Machine	5
Removing the Landscape Rake from the Carrier Machine	5
Transporting.....	6
Storage	6
OPERATION AND INSPECTION	7
Equipment Inspection.....	7
Usage Guidelines.....	7
Inspection Checklist	7
THE SKID STEER.....	8
General Information	8
Operating the Skid Steer	8
During Operation.....	9
Roll-Over Protective Structure (ROPS) During Operation.....	9
MAINTENANCE.....	10
Landscape Rake PARTS	11
Detailed Parts Diagram A.....	11
Detailed Parts - List A	12
Warning Decals - List A.....	12
TORQUE SPECIFICATION TABLE	13
General Specification Table	13
SKID PRO ATTACHMENT WARRANTY	14

INTRODUCTION

To the Purchaser

All products are designed to give safe, dependable service if they are operated and maintained according to instructions. Read and understand this manual before operation.

This manual has been prepared to assist the owner and operators in the safe operation and suitable maintenance of the equipment. The information was applicable to products at the time of manufacture and does not include modifications made afterwards.

Read and understand this operator's manual before attempting to put equipment into service. Familiarize yourself with the operating instructions and all the safety recommendations contained in this manual and those labeled on the equipment and on the skid steer. Follow the safety recommendations and make sure that those with whom you work follow them.

Illustrations

The illustrations may not necessarily reproduce the full detail and the exact shape of the parts or depict the actual models, but are intended for reference only.

Direction Reference

All references to right and left, forward or rearward, are from the operator's seat, facing the steering wheel.

Serial Plate



To assist your dealer in handling your needs, please record hereafter the model number and the serial number of your equipment and skid steer. It is also advisable to supply them to your insurance company. It will be helpful in the event that an equipment or skid steer is lost or stolen.

SKID STEER

IMPLEMENT

MODEL: _____

SERIAL NUMBER: _____

DATE OF PURCHASE: _____

DEALER NAME: _____

SAFETY PRECAUTIONS



SAFETY FIRST

This symbol, the industry's "Safety Alert Symbol", is used throughout this manual and on labels on the machine itself to warn of the possibility of personal injury. Read these instructions carefully. It is essential that you read the instructions and safety regulations before you attempt to assemble or use this unit.



DANGER: Indicates an immediate hazardous situation which, if not avoided, will result in death or serious injury.



WARNING: Indicates a potentially hazardous situation which, if not avoided, will result in death or serious injury.



CAUTION: Indicates a potentially hazardous situation which, if not avoided, may result in minor or moderate injury.

IMPORTANT: Indicates that equipment or property damage could result if instructions are not followed.

NOTE: Gives helpful information.

All products are designed to give safe, dependable service if they are operated and maintained according to instructions. **Read and understand this manual before operation.** It is the owner's responsibility to be certain anyone operating this product reads this manual, and all other applicable manuals to become familiar with this equipment and all safety precautions. Failure to do so could result in serious personal injury or equipment damage. A safe operator is the best assurance against accidents. All operators, no matter how experienced they may be, should read this operator's manual and all other related manuals before attempting to operate the equipment. Please read the following section and pay particular attention to all safety recommendations contained in this manual and those labeled on the equipment and on the skid steer.

Children

Tragic accidents can occur if the operator is not alert to the presence of children. Children are generally attracted to machines and work being done. Never assume children will remain where you last saw them.

1. Keep children out of the operating area and under the watchful eye of another responsible adult.
2. Be alert and turn machine off if children enter the work area.
3. Before and when backing, look behind for small children, use care when approaching blind corners.
4. Never carry children while operating the machine. They may fall off and be seriously injured or interfere with the safe operation of the machine.
5. Never allow children to play on the machine or attachment even when they are turned off.
6. Never allow children to operate the machine even under adult supervision.

Safety Precautions – Landscape Rake

1. Read and understand this operator's manual and skid steer operator's manual. Know how to operate all controls and how to stop the unit and disengage the controls quickly.
2. Never wear loose, torn, or bulky clothing around the skid steer and the Landscape Rake. It may catch on moving parts or controls, causing injury.
3. Before and during use, thoroughly inspect the area where the equipment is to be used and remove all objects that may cause damage to the equipment.
4. Set transmission to neutral and disengage clutch, if equipped, before starting the engine.
5. Do not operate equipment without protective clothing.
6. Never attempt to make any adjustments while engine is running. Read this manual carefully to acquaint yourself with the equipment as well as the skid steer operator's manual. Working with unfamiliar equipment can lead to accidents. Be thoroughly familiar with the controls and proper use of the equipment.
7. Keep all safety guards in place and verify hardware for proper tightening.
8. Check for moving parts excessive wear regularly. Replace worn parts with genuine parts.
9. Replace all missing, illegible, or damaged safety and warning decals. See list of decals in operator's manual.
10. Keep safety decals clean of dirt and grime.
11. Do not modify or alter this equipment or any of its components, any equipment or any of its components or any equipment function without first consulting your dealer.

Safety Notices

Before operating or conducting maintenance on this equipment, it is important to wear proper protection. Recommended safety equipment when operating and maintaining this equipment includes earplugs, eye protection, and a hard hat.

NOTE: Additional safety equipment may be required depending on the operating environment and worksite conditions.

Only qualified and trained personnel should operate, maintain, and service this attachment. It is recommended that this equipment be inspected regularly for leaks, cracks, or other conditions that may impair proper usage of the equipment. Verify that all repairs have been completed and inspected prior to using the attachment under load.

It is the responsibility of the user to follow all local, state, and federal safety regulations. Improper use of this equipment may result in personal injury, property damage, and/or damage to the equipment.

Modifications to Equipment

Any modifications made to this equipment may void any warranty and relieve the manufacturer of liability of any resulting injury or damage.

ABOUT THE Landscape Rake ATTACHMENT

The Landscape Rake attachment is intended for use in small debris picking. The primary use of the Landscape Rake attachment includes rock picking, gravel smoothing, site preparation. Use of this equipment in any other manner is considered to be contrary to the intended use of the attachment.

Attaching the Landscape Rake to the Carrier Machine

NOTE: Before attempting to attach the Landscape Rake to the carrier machine, verify that all hydraulic couplings are compatible.

WARNING – Improper attachment to the carrier machine may cause personal injury.

CAUTION – All hydraulic connections must be clean and free of debris before making any connection.

1. Place the Landscape Rake on a level surface.
2. Position and align the carrier machine to the rear of the attachment, within proximity of the front of carrier machine.
3. Insert and connect the carrier machine into the attachment.
4. Connect the hydraulic lines from the attachment to the carrier machine.
5. Close latches (or other locking mechanism) to secure the attachment to the carrier machine.
6. Using the carrier machine, raise the attachment and move the attachment to ensure hydraulic lines are clear of air and operate properly.

CAUTION – Hydraulics should operate in an even and smooth manner. Hydraulic movement that is not even and smooth may indicate that air is in the hydraulic lines.

7. Lower the attachment to ground level.
8. Inspect that the attachment is mounted properly and securely. If the attachment does not meet this requirement, follow the instructions to remove the Landscape Rake and re-attach using the instructions above.

Removing the Landscape Rake from the Carrier Machine

WARNING – Improper disconnection may result person injury or damage to the attachment and carrier machine.

CAUTION – All hydraulic connections must be clean and free of debris before disconnection.

1. Using the carrier machine, lower the attachment to the ground.
2. To prevent contamination, remove any dirt and debris from the couplings. Disconnect the hydraulic connection between the attachment and the carrier machine.

NOTE: Hydraulic connections must be disconnected before disengaging latches to prevent damage to the carrier machine or the attachment.

3. Disengage the carrier machine latches (or other locking mechanisms) from the attachment.
4. Move the carrier machine from the attachment.

Transporting

1. Transporting on public roadway: When driving the skid steer and equipment on the road or highway under 25 mph, at night or during the day, use flashing amber warning lights and the Slow Moving Vehicle ("SMV") identification emblem.
2. Check local traffic codes that may apply to unit usage on public roads and highways in your area. The use of flashing amber lights is acceptable in most localities. However, some localities may prohibit their use.
3. Always disengage equipment drive prior to transporting unit.

Storage

Before storing the Landscape Rake, certain precautions should be taken to protect it from deterioration.

1. Clean the landscape rake throughout.
2. Make all the necessary repairs.
3. Replace all safety signs that are damaged, lost, or otherwise become illegible. If a part to be replaced has a sign on it, obtain a new safety sign from your dealer and install it in the same place as on the removed part.
4. Repaint all parts from which paint has worn or peeled.
5. When the Landscape Rake is dry, oil all moving parts. Apply oil liberally to all surfaces to protect against rust.
6. Store in a dry place

OPERATION AND INSPECTION

Equipment Inspection

It is recommended to inspect the equipment for damage and wear before use. Use the following list as a guideline during equipment inspection.

- Check all hardware connections to the carrier machine for damage or fatigue such as cracks or other structural flaws.
- Check that all latches or locks are closed.
- Check that all hydraulic fittings are tight and free of leaks
- Check that all hydraulic lines are free of leaks, holes, or cracks.

WARNING – Do not use hands to check for hydraulic leaks. Keep body parts away from leaking hydraulic lines and couplings that are under pressure.

- Check that the tires on the carrier machine are in good condition and have proper load ratings.

NOTE: Replace any damaged hardware, hoses, and fittings before using the equipment.

Usage Guidelines

Before each use do the following:

- Perform daily maintenance as indicated in the Daily Maintenance Schedule.
- Inspect the attachment by performing a walk around

DANGER – Keep all body parts away from the Landscape Rake when in use.

Inspect the Landscape Rake daily before use. It is also recommended to inspect the Landscape Rake after extreme use or damage. Use the following inspection checklist as a guideline.

Inspection Checklist

- Are all safety notices and warning decals in proper locations and visible?
- Are there any visible hydraulic leaks?
- Are any cracks visible in Landscape Rake structure?
- Have all grease fittings (zerk fittings) have been greased?
- Are the bolts holding pins secure and tight?
- Has the carrier machine been properly inspected for hydraulic leaks and proper tire inflation?
- Has the carrier machine been properly maintained?

THE SKID STEER

General Information

1. Read the operator's manual carefully before using skid steer. Lack of operating knowledge can lead to accidents.
2. Do not permit anyone but the operator to ride on the skid steer. There is no safe place for passengers.

Operating the Skid Steer

1. Never run the skid steer engine in a closed building without adequate ventilation, as the exhaust fumes are very dangerous.
2. Adopt safe driving practice: Keep the parking brake on at all times during transportation.
3. Always drive at a safe speed relative to local conditions and ensure that your speed is low enough for an emergency stop to be safe and secure.
4. Reduce speed prior to turns to avoid the risk of overturning. Keep speed to a minimum.
5. Always keep the skid steer in gear to provide engine braking when going downhill. Do not coast.
6. Never allow an open flame near the fuel tank or battery.
7. Make sure the proper shields are installed when using the equipment and always replace the shields if damaged.
8. Park the skid steer/Landscape Rake on level ground, place the transmission in neutral, set the parking brake, disengage the Aux hydraulics, lower the equipment to the ground, place all levers including auxiliary control levers in neutral, shut off the engine and remove the ignition key BEFORE leaving the skid steer.
9. Never park or operate the skid steer on a steep slope. Avoid sudden uphill turns on steep slopes.
10. Use of counterweights for better traction and stability is recommended.
11. Handle fuel with care, as it is highly flammable.
12. Use approved fuel container, never add fuel to running engine or a hot engine.
13. Fill fuel tank outdoors with extreme care. Never fill fuel tank indoors. Replace fuel cap securely and wipe up spilled fuel.
14. Never allow anyone to operate the Landscape Rake until they have read the manual completely and are thoroughly familiar with basic skid steer and Landscape Rake operation.
15. Make sure the skid steer is counterweighted as recommended by your dealer. Weights provide the necessary balance to improve stability, traction and steering.
16. Always make sure all Landscape Rake components are properly installed and securely fastened BEFORE operation.
17. Always start the engine from the operator's seat with all the transmission lever(s) and Landscape Rake drive lever in neutral.
18. DO NOT bypass the safety system by shorting across the terminals of the starter motor to start the engine. This may cause the skid steer to move suddenly.
19. If the safety start system does not work, consult your dealer immediately.

During Operation

1. Do not allow passengers on the skid steer/Landscape Rake at any time. There is no safe place for passengers on the equipment. The operator **MUST** sit in the skid steer seat.
2. Eye and hearing protection is recommended when operating the Landscape Rake.
3. Operate only during daylight hours, or when the area is well lit with bright artificial light.
4. Park the skid steer/Landscape Rake on level ground, place the transmission in neutral, set the parking brake, disengage the Aux hydraulics, lower the equipment to the ground, place all control levers in neutral, shut off the engine and remove the ignition key **BEFORE** leaving the operator's seat.
5. Inspect the Landscape Rake after striking any foreign object to assure that all Landscape Rake parts are safe and secure and not damaged.
6. Be especially observant of the operating area and terrain. Watch for holes, rocks, or other hidden hazards. **ALWAYS** inspect the area prior to using the Landscape Rake.
7. **DO NOT** use the Landscape Rake near the edge of drop-offs or banks.
8. **DO NOT** use the Landscape Rake on steep slopes as overturn may result.
9. Operate up and down (not across) intermediate slopes. Avoid sudden starts and stops.
10. Drive skid steer backwards up steeper slopes.
11. Slow down before you change directions on any slope.
12. Use wheel weights on your skid steer to increase stability on slopes.
13. Never stand alongside of the unit while the engine is running.

Roll-Over Protective Structure (ROPS) During Operation

1. **DO NOT** weld, drill or alter the ROPS. Damaged ROPS must not be straightened or used. If damage does occur, consult your dealer.
2. If ROPS is lowered or removed from the skid steer for any reason, it must be erected and/or refitted immediately. Original bolts or equivalent replacements must be used and tightened to the correct torque.
3. Your dealer does not recommend usage of skid steer with ROPS removed.
4. Seat belt usage: With ROPS installed on the skid steer it is imperative that the seat belt be installed, used and correctly adjusted, at all times. **DO NOT** use a seat belt if operating without ROPS.
5. Keep all shields and covers in place. All skid steer and equipment shields and covers must be correctly installed at all times. When necessary to remove these, they must be reinstalled immediately.
6. Keep clear of all rotating driveline components. Be especially observant of implement areas of discharge, intake or other mechanical motion.
7. Securely lock equipment drive shaft. Check that all skid steer and equipment drivelines are in good working order.
8. Additional safety equipment: A fire extinguisher and first aid kit should be kept readily accessible.

MAINTENANCE

Always use genuine parts when replacement parts are required during operation.

1. Keep the skid steer and Landscape Rake properly maintained.
2. Park the skid steer/Landscape Rake on level ground, place the transmission in neutral, set the parking brake, disengage the Aux hydraulics, lower the equipment to the ground, place all control levers in neutral, shut off the engine and remove the ignition key and allow the rotating parts to stop BEFORE making any Landscape Rake adjustments.
3. To avoid injury, do not adjust or service the Landscape Rake with the skid steer engine running. Make sure moving components have completely stopped before leaving the operator's seat.
4. Keep the skid steer/Landscape Rake clean.
5. Always wear eye protection when cleaning or servicing the Landscape Rake.
6. Service the unit in safety: DO NOT service the skid steer while the engine is running or hot, or if the unit is in motion. Always lower Landscape Rake to the ground. If necessary to service unit with Landscape Rake raised, securely support with stands or suitable blocking before working underneath. Do not rely on hydraulically supported devices for your safety. They can settle suddenly, leak down, or be accidentally lowered.
7. Do not attempt to service machine, clear obstructions or unplug blockages with the engine running. Always shut off engine and allow all motion to cease.
8. The manufacturer will not claim responsibility for fitment of unapproved parts and/or accessories and any damages as a result of their use.
9. Make sure all shields and guards are securely in place following all service, cleaning, or repair work.
10. Do not modify or alter this equipment or any of its components or operating functions. If you have any questions concerning modifications, consult with your dealer.
11. Do not operate a unit which is defective or has missing parts. Make sure that all recommended maintenance procedures are completed before operating the unit.
12. Check all controls regularly and adjust where necessary.
13. Periodically check all nuts and bolts for tightness, especially wheel hub and rim nuts. Make sure all non-rotating pins are secured properly.
14. Check hydraulic cylinders and hoses for damage or leaks. To avoid serious personal injury: Escaping hydraulic/diesel fluid under pressure can penetrate the skin causing serious injuries. Do not use your hands to check for leaks. Use a piece of cardboard or paper to search for leaks.
15. Stop engine and relieve pressure before connecting lines. Tighten all connections before starting engine or pressurizing lines.

SKID PRO ATTACHMENT WARRANTY

Skid Pro warrants above attachments for twenty-four months from date of shipment, to the original owner. Warranty covers products to be free from defects in material and workmanship when properly set up and operated in accordance with Skid Pro's recommendations.

WARRANTY CLAIM PROCEDURE

All warranty claims must be submitted within the manufacturer's limited warranty period. Pictures and/or a video of the failing component(s) are required to properly document all potential warranty claims. To submit a warranty claim, contact your Skid Pro Product Guru or complete a [Warranty Claim Form](#) on our website and send it along with supporting pictures/video to sales@skidpro.com. Upon receipt, the warranty claim information will be reviewed and once determined to be a valid claim, a return authorization number will be issued for the return of the defective part(s) if applicable and replacement part(s) will be shipped. If it is determined the defective parts are to be returned and they are not received by Skid Pro within 30 days of receiving the replacement parts, the Buyer will be charged for the cost of the replacement parts plus any shipping charges. Tampering with the failed part (i.e. disassembling a motor or cylinder) will void the warranty.

EXCLUSIONS OF WARRANTY

Skid Pro's requirement for any issue with respect to attachments shall be limited to repairing or replacing the defective part, as this is a parts-only warranty and does not include any labor to replace or install the part or downtime from resulting issue. Skid Pro has full technical support & assistance to assure customer replaces the part properly for optimal performance on attachment.

This warranty shall not apply to any attachment's wear items, or attachments that have been repaired or altered outside the Skid Pro factory in any way, or that has been subject to misuse, negligence or accident beyond Skid Pro's recommended use and/or machine rated capacity.

This warranty is exclusive and in lieu of all other warranties and conditions. Skid Pro disclaims all other warranties and conditions, express or implied, including any implied warranties or conditions of merchantability or fitness for a particular purpose. In no event shall Skid Pro be liable for any special, incidental, indirect or consequential damage, whatsoever, including, but not limited to, loss or interruption of business, lost profits, or loss of machine use, whether based on contract, warranty, tort, negligence, strict liability, statute or otherwise, even if Skid Pro has been advised of the possibility of such damages.

No agent, employee, or representative of Skid Pro has any authority to bind said company to any affirmation, representation, or warranty concerning its machinery and/or attachments except as specifically set forth herein. Any disagreement or dispute of warranty policy or customer expectations of product, soundness, functionality, or performance would take place in Douglas County, Alexandria, MN, where Skid Pro operates.

800-01-0001-72 LANDSCAPE RAKE

PARTS BREAKDOWN

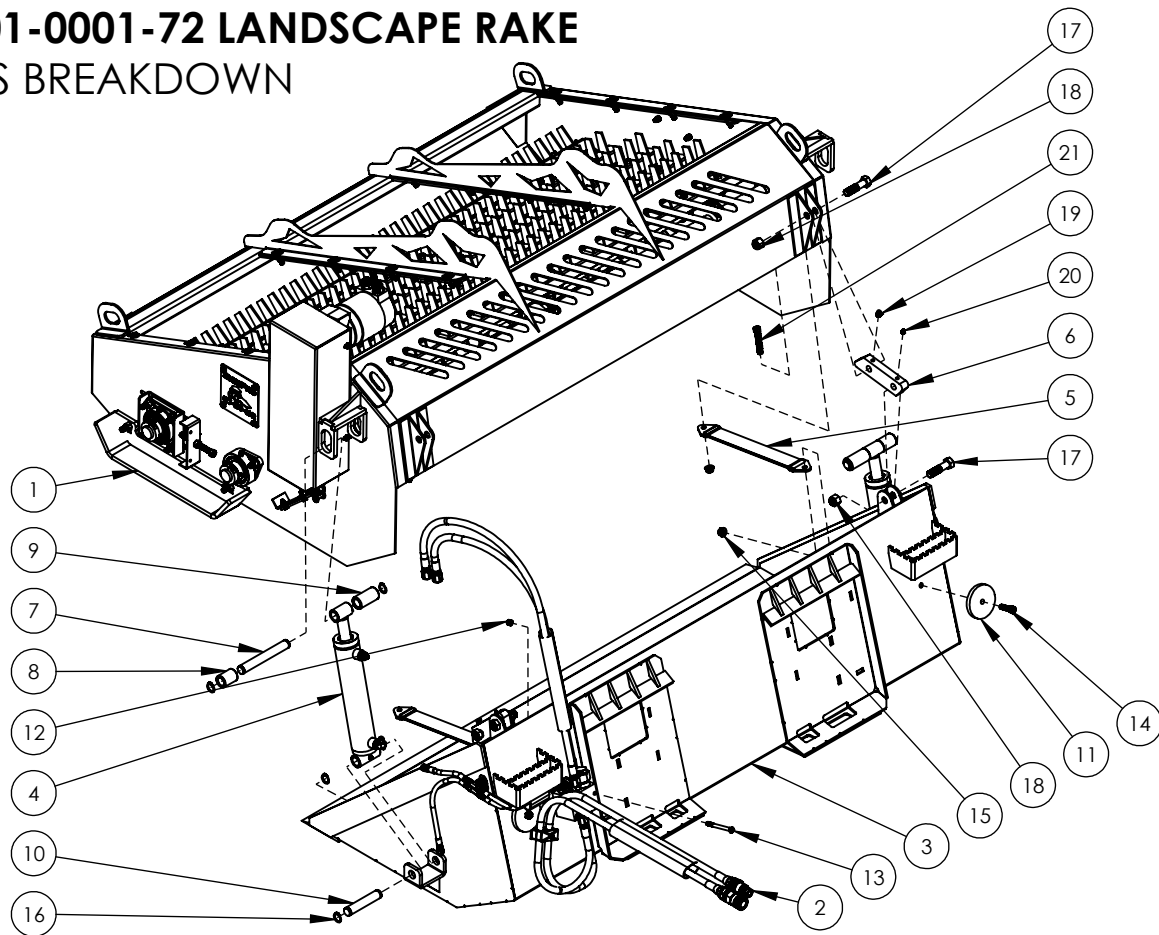

ITEM NO.	PART NUMBER	DESCRIPTION	QTY.
1	SHROUD ASSEMBLY	SHROUD COMPONENTS/ASSEMBLY	1
2	HYDRAULICS	HYDRAULIC COMPONENTS	1
3	800-02-0001-72	72" LANDSCAPE RAKE BUCKET	1
4	657-02-0010	2.5 X 10 CYLINDER	2
5	800-03-0066	STOP STRAP	2
6	800-03-0025	LINKAGE	2
7	800-03-0029	UPPER CYLINDER PIN	2
8	800-03-0042	OUTSIDE BUSHING	2
9	800-03-0041	INSIDE BUSHING	2
10	800-03-0046	CYLINDER PIN	2
11	800-03-0065	REINFORCEMENT	2
12	HW-.375-16NYL	3/8 - 16 NYLOCK NUT	10
13	HW-.375-16X4.0G5	3/8"-16 X 4" GRADE 5 BOLT	2
14	HW-.500-13X1.75G8	1/2"-13X1 3/4" GRADE 8 BOLT	2
15	HW-.500-13FLN	1/2"-13 FLANGE NUT GR8	4
16	657-3-0080	1" SNAP RING	8
17	HW-.750-16X3G8	3/4-16X3 HH BOLT G8 ZINC FINE THREAD	4
18	HW-.750-16NYLG8	3/4"-16 NYLOCK NUT G8	4
19	HW-.125-90DEGGF	.125" 90° ANGLE GREASE ZERK	2
20	HW-.125-NPTSGF	GREASE ZERK	2
21	HW-.500-13X3G8	1/2"-13 X 3" G8	2

SHROUD ASSEMBLY PARTS BREAKDOWN

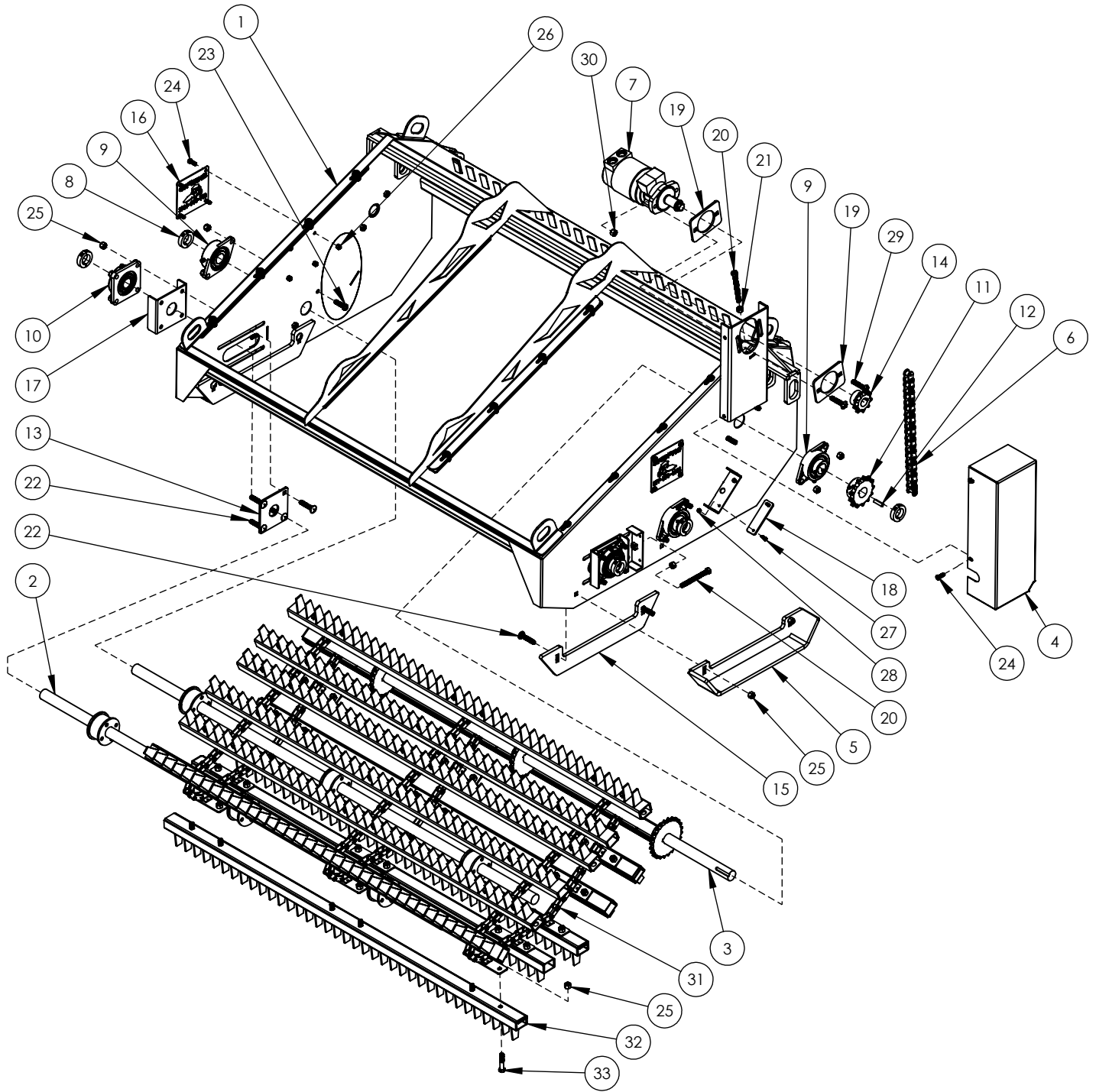

SHROUD ASSEMBLY BOM

PARTS BREAKDOWN

ITEM NO.	PART NUMBER	DESCRIPTION	QTY.
1	800-02-0002-72	72" LANDSCAPE RAKE HOOD	1
2	800-02-0003-72	72" CHAIN BAR	2
3	800-02-0004-72	CHAIN DRIVE BAR	1
4	800-02-0012	CHAIN GUARD	1
5	800-02-0013	SKID SHOE	2
6	AU-03-80H-40	40" 80 HEAVY CHAIN	1
7	800-03-0050	HYDRAULIC MOTOR	1
8	AU-02-35033	1.5" SHAFT COLLAR	6
9	800-03-0056	2 BOLT FLANGE BEARING	4
10	800-03-0055	4 BOLT FLANGE BEARING	2
11	800-03-0052	13 TOOTH 80 PITCH, 1 1/2 SHAFT	1
12	800-03-0020	3/8 X 1.50 KEYWAY	1
13	800-03-0021	BOLT PLATE	2
14	AU-03-4005	9 TOOTH 1.0PITCH 1.25BORE .313KEY	1
15	800-03-0070	FRONT SKID	2
16	SP-2019-4	SKIDPRO PLACARD	2
17	800-03-0045	BEARING PUSH PLATE	2
18	800-03-0058	SIDE SHIM	2
19	800-03-0071	SUPPORT PLATE	2
20	HW-.500-13X5G5TB	1/2"-13 X 5" GRADE 5 TAP BOLT	3
21	HW-.500-13NUT	1/2"-13 HEX NUT G5	3
22	HW-.500-13X2.5CB	GRADE 5 STEEL SQUARE-NECK CARRIAGE BOLT	12
23	HW-.500-13X1.75G5	1/2"-13 X 1-3/4" GRADE 5 BOLT	8
24	HW-.375-16X1.0G5	3/8"-16X1" HEX BOLT G5	12
25	HW-.500-13NYL	1/2-13 NYLOCK NUT ZINC	92
26	HW-.375-16NYL	3/8 - 16 NYLOCK NUT	8
27	HW-.25-20X1.0G5	1/4"-20X1" GRADE 5 BOLT	4
28	HW-.25-20NYL	1/4"-20 NYLOCK NUT	4
29	HW-.500-13X2.5G8CB	HIGH-STRENGTH GRADE 8 STEEL SQUARE-NECK CARRIAGE BOLT	2
30	HW-.500-13NYLG8	1/2"-13 NYLOCK NUT G8	2
31	800-02-0021	TOOTH BAR CHAIN	3
32	800-02-0014-72	TOOTH BAR	12
33	HW-.500-13X2.50G5	1/2"-13 X 2 1/2" GRADE 5 BOLT	72

800-02-0022-72 TOOTH BAR KIT ASSEMBLY

KIT PARTS

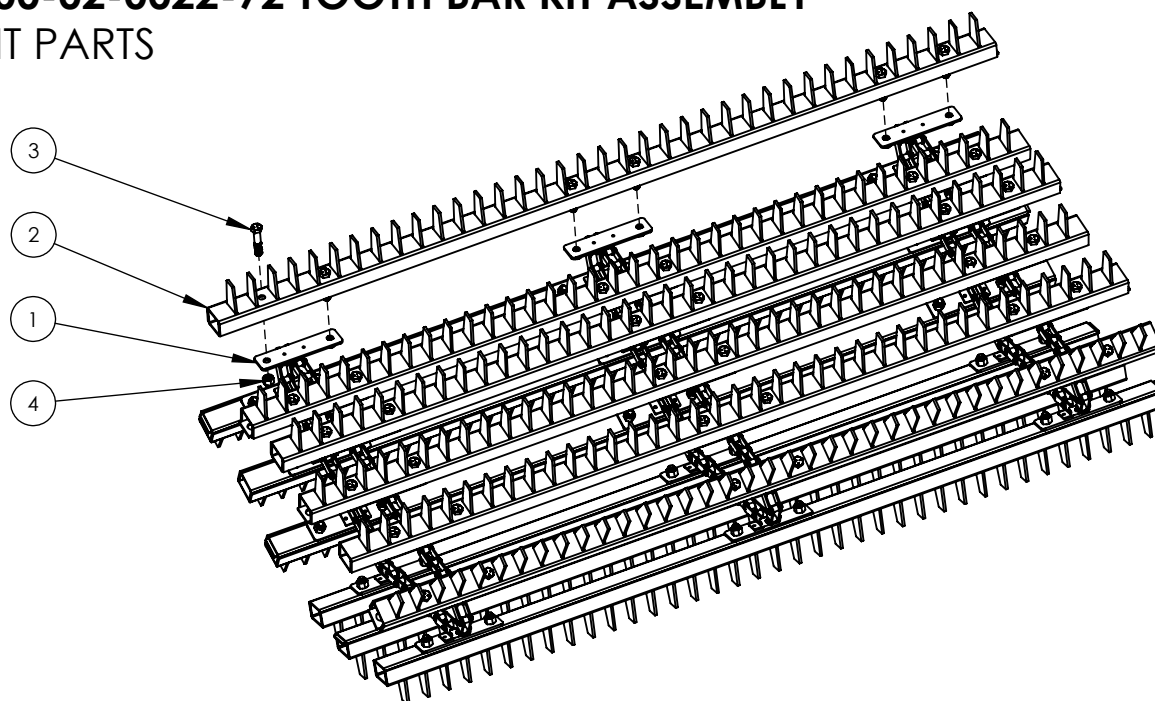

ITEM NO.	PART NUMBER	DESCRIPTION	QTY.
1	800-02-0021	TOOTH BAR CHAIN	3
2	800-02-0014-72	TOOTH BAR	12
3	HW-.500-13X2.50G5	1/2"-13 X 2 1/2" GRADE 5 BOLT	72
4	HW-.500-13NYL	1/2-13 NYLOCK NUT ZINC	72

800-02-0021 TOOTH BAR CHAIN

PARTS BREAKDOWN

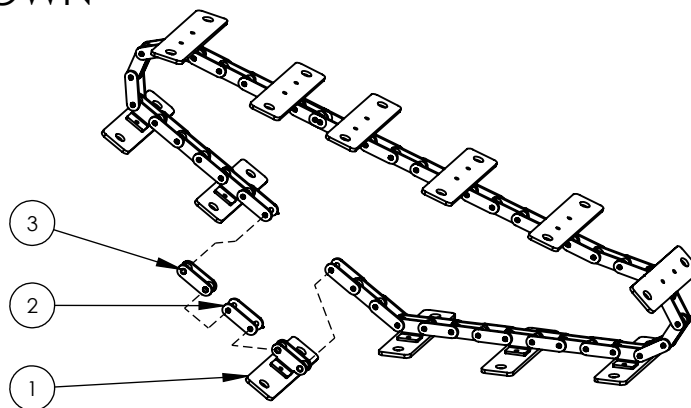

ITEM NO.	PART NUMBER	DESCRIPTION	QTY.
1	800-02-0020	TOOTH BAR BOLTING PLATE	12
2	800-03-0082	CONNECTING LINK, C2060H	24
3	800-03-0081	ADDING LINK, C2060H	12

800-01-0001-72 HYDRAULICS

PARTS BREAKDOWN

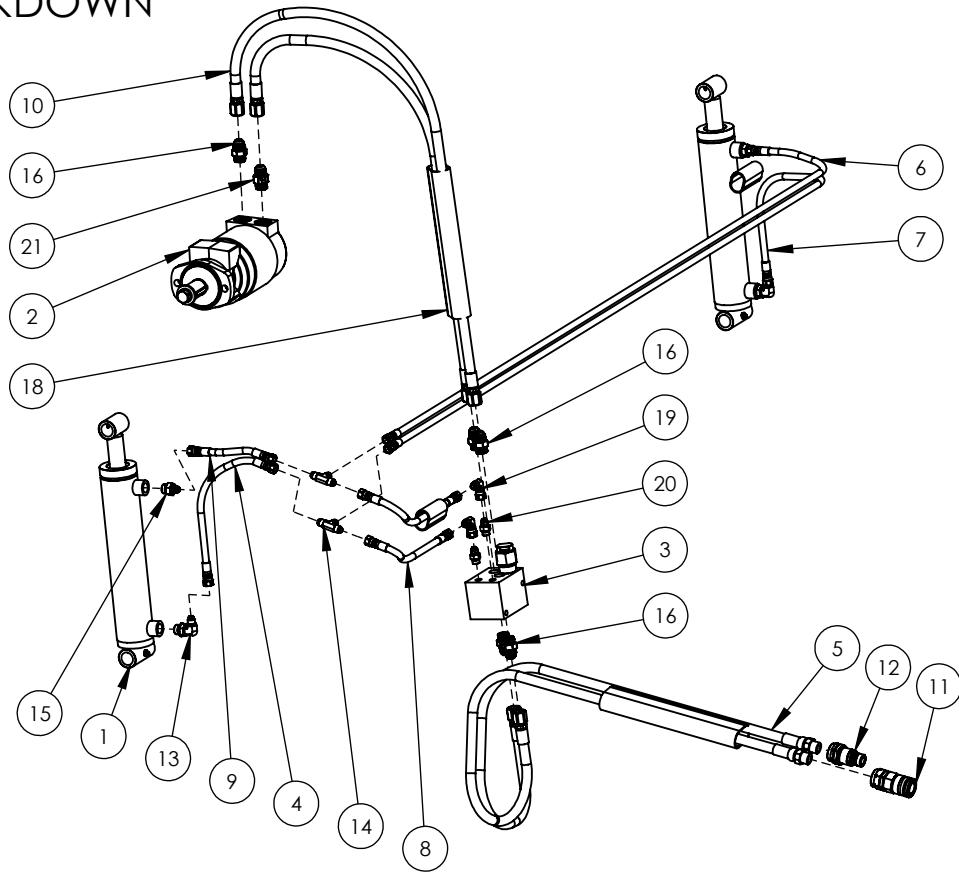

ITEM NO.	PART NUMBER	DESCRIPTION	QTY.
1	657-02-0010	2.5 X 10 CYLINDER	2
2	800-03-0050	HYDRAULIC MOTOR	1
3	800-02-0007	SEQUENCE HYD VALVE	1
4	777-02-0005	1/4"X17" HOSE -6FJIC -6FJIC	1
5	H500-84-10J12MORB	1/2" X 84" HOSE-10FJIC-12MORB	2
6	H250-84-6J6J	HOSE 1/4 X 84 6FJIC 6FJIC	1
7	H250-96-6J6J	HOSE 1/4 X 96 6FJIC 6FJIC	1
8	777-02-0030	1/4"X14" HOSE 6FJIC-6FJIC	2
9	H250-8-6J6J	1/4" X 8" HOSE -6FJIC-6FJIC	1
10	H500-48-10FJX	HOSE 1/2" X 48" -10FJIC-10FJIC	2
11	AU-03-9990-12-12	1/2" FEMALE COUPLER	1
12	AU-03-9991-12-12	1/2" MALE COUPLER	1
13	H250-FT2062-8-6S	8 MORB X 6MJIC 90DEG	2
14	H250-6MJICTEE	6MJIC UNION TEE	2
15	H375-FT21-6-8	-8 M ORB X -6 M JIC	2
16	H750-6400-10-10	ADAPTER -10 MORB X -10MJIC	5
17	HSL250	.250" HOSE SLEEVE	2 FT
18	HSL500	HOSE SLEEVE	10 FT
19	H250-FT6JIC-SE	-6JICM X -6JICF 90 ELBOW	2
20	H375-FT21-6-6	-6 MJIC X -6 MORB	2
21	H750-1110R	-10 MORB X -10MJIC R CHECK	1

800-01-0001-72

REPLACEMENT DECALS

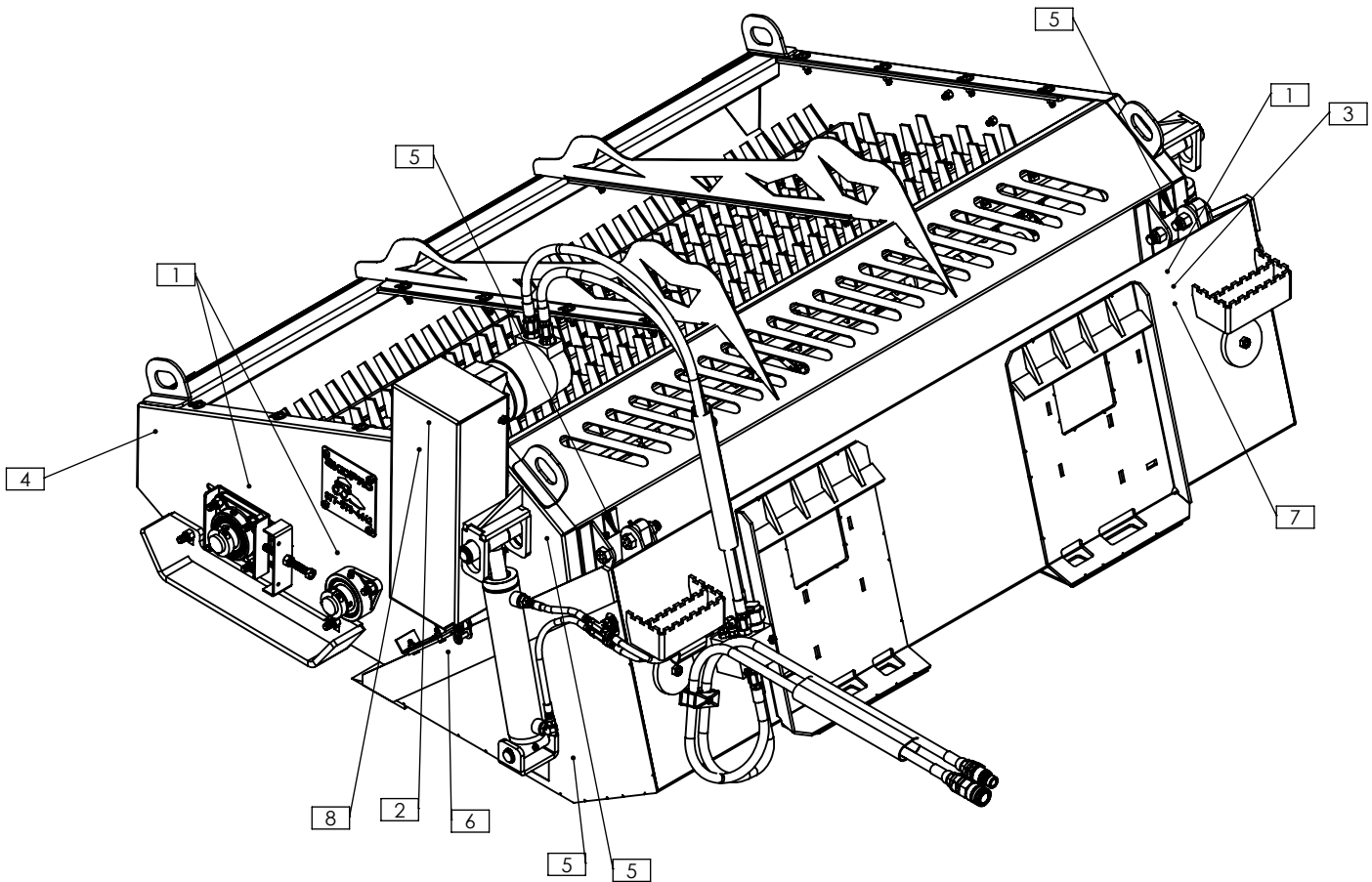

DECAL NO.	PART NUMBER	DESCRIPTION	QTY.
1	DECAL-3-0154	800-01-0001 SERIAL DECAL	1
2	DECAL-3-0074	YELLOW "CAUTION DO NOT OPERATE"	1
3	DECAL-3-0034	72" SILVER	1
4	DECAL-3-0028	"DANGER"	2
5	DECAL-3-0019	"GREASE DAILY" .75X2	11
6	DECAL-3-0015	DANGER KEEP HANDS CLEAR	2
7	DECAL-3-0009	3X3 "READ OWNERS MANUAL"	1
8	DECAL-3-0008	3X5 "HIGH PRESSURE FLUID"	1



**PO BOX 982
Alexandria, MN 56308**

**Phone: 877-378-4642
FAX: 320-759-1057
www.skidpro.com
sales@skidpro.com**