



## **Disc Mulcher**

# **Operation and Maintenance Manual**

Revision Date: Nov. 2024

**Skid Pro Attachments**

PO Box 982  
Alexandria, MN 56308  
Toll Free: 877-378-4642  
www.skidpro.com

**Contents**

**ABOUT THIS OWNER’S MANUAL ..... 2**  
Hazard Notices ..... 2  
Terminology ..... 2  
**SAFETY ..... 2**  
Safety Notices ..... 2  
Modifications to Equipment..... 2  
**ABOUT THE Disc Mulcher ATTACHMENT..... 3**  
Attaching the Disc Mulcher to the Carrier Machine ..... 3  
Removing the Disc Mulcher from the Carrier Machine ..... 3  
**Disc Mulcher OPERATION ..... 4**  
**EQUIPMENT INSPECTION SCHEDULE..... 5**  
Daily Inspection ..... 5  
Weekly Inspection ..... 5  
Monthly Inspection..... 5  
Inspection Checklist..... 6  
**PARTS DIAGRAMS AND LISTS ..... 7-11**  
**SKID PRO ATTACHMENT WARRANTY..... 12**

## ABOUT THIS OWNER'S MANUAL

This manual contains information about the usage and maintenance required for the equipment. This document must be available for review by the operator before using the attachment to ensure proper safety, maintenance, and usage.

### Hazard Notices

The following hazard notices are used in this document:

**NOTE:** Notes are used to indicate important information. This information may be repeated in other areas of the manual.

**CAUTION:** Cautions are used to indicate a potentially hazardous situation, which, if not avoided, may result in damage to the equipment or other property.

**WARNING:** Warnings are used to indicate a potentially hazardous situation, which, if not avoided, could result in serious injury or death.

**DANGER:** Danger is used to indicate a potentially hazardous situation, which, if not avoided, will result in serious injury or death.

### Terminology

**Carrier Machine:** The Disc Mulcher can be attached to many different pieces of equipment; therefore, the term "carrier machine" will be used. A carrier machine is any equipment, tractor, or skid steer providing power to the attachment.

## SAFETY

### Safety Notices

Before operating or conducting maintenance on this equipment, it is important to wear proper protection. Recommended minimum safety equipment when operating and maintaining this equipment includes earplugs, eye protection, and a hard hat. A heavy-duty Lexan door or cab is also recommended.

**NOTE:** Additional safety equipment may be required depending on the operating environment and worksite conditions.

Only qualified and trained personnel should operate, maintain, and service this attachment. Skid Pro recommends that you inspect this equipment regularly for leaks, cracks, or other conditions that may impair proper usage of the equipment. Verify that all repairs have been completed and inspected prior to using the attachment under load.

It is the responsibility of the user to follow all local, state, and federal safety regulations. Improper use of this equipment may result in personal injury, property damage, and/or damage to the equipment.

**NOTE:** Fasten the lift limiter safety chain to your machine with very little slack. See Safety Chain Placement section.

**DANGER: THE DISC MULCHER CAN THROW DEBRIS FOR A LONG DISTANCE. DO NOT HAVE ANYONE OUTSIDE THE CAB STANDING WITHIN 200 YARDS OR 600 FEET. FAILURE TO DO SO COULD RESULT IN INJURY OR DEATH.**

### Modifications to Equipment

Any modifications made to this equipment may void any warranty and relieve the manufacturer of liability of any resulting injury or damage.

## ABOUT THE DISC MULCHER ATTACHMENT

The Disc Mulcher attachment is intended for use as a brush or tree cutting and clearing tool. The primary use of the Disc Mulcher attachment includes land clearing, landscaping, and grounds maintenance. Use of this equipment in any other manner is contrary to the intended use of the attachment.

### Attaching the Disc Mulcher to the Carrier Machine

**NOTE:** Before attempting to attach the Disc Mulcher to the carrier machine, verify that all hydraulic couplings are compatible.

**WARNING:** Improper attachment to the carrier machine may cause personal injury.

**CAUTION:** All hydraulic connections must be clean and free of debris before making any connection.

1. Place the Disc Mulcher attachment on a level surface.
2. Position and align the carrier machine to the rear of the attachment, within proximity of the front of carrier machine.
3. Insert and connect the carrier machine into the attachment.
4. Connect the hydraulic lines from the attachment to the carrier machine.
5. Close latches (or other locking mechanisms) to secure the attachment to the carrier machine.
6. Using the carrier machine, raise the attachment and move the attachment to ensure hydraulic lines are clear of air and operate properly.

**CAUTION:** Hydraulics should operate in an even and smooth manner. Hydraulic movement that is not even and smooth may indicate that air is in the hydraulic lines.

7. Lower the attachment to ground level.
8. Inspect that the attachment is mounted properly and securely. If the attachment does not meet this requirement, follow the instructions to remove the Disc Mulcher and re-attach using the instructions above.

### Removing the Disc Mulcher from the Carrier Machine

**WARNING:** Improper disconnection may result personal injury or damage to the attachment and carrier machine.

**CAUTION:** All hydraulic connections must be clean and free of debris before disconnection.

1. Using the carrier machine, lower the attachment to the ground.
2. To prevent contamination, remove any dirt and debris from the couplings. Disconnect the hydraulic connection between the attachment and the carrier machine.



**NOTE:** Hydraulic connections must be disconnected before disengaging latches to prevent damage to the carrier machine or the attachment.

3. Disengage the carrier machine latches (or other locking mechanisms) from the attachment.
4. Move the carrier machine from the attachment.

## Disc Mulcher OPERATION

- Operate this attachment with a carrier machine and protective door.
- Wear proper safety equipment as required by working conditions and local, state, and Federal laws.
- Never operate the Disc Mulcher within 600 feet of people, animals, or damageable property. Clear the area of objects that could become projectiles, such as rocks, bottles, and construction debris.
- Never operate the Disc Mulcher with any guards removed, including the motor cover.
- Disengage the Disc Mulcher and shut off the engine before leaving the cab of your machine.
- Do not place hands or feet near the Disc Mulcher while the machine is running.
- **Disc Mulchers are rated for up to 60 GPM with a maximum PSI of 4500.**

**DANGER:** Keep all body parts away from the Disc Mulcher when in use.

	<b>Eye and Ear Protection:</b> To help ensure your safety as a designated operator wear eye and ear protection.
	<b>Safety Helmet:</b> To help ensure your safety as a designated operator wear a safety helmet.

# EQUIPMENT INSPECTION SCHEDULE

We recommend that you inspect the equipment for damage and wear before every use. Use the following list as a guideline during equipment inspection.

**WARNING:** Do not use hands to check for hydraulic leaks. Keep body parts away from leaking hydraulic lines and couplings that are under pressure.

**NOTE:** Shut off the carrier machine and disengage the Disc Mulcher before performing any maintenance.

## Daily Inspection

Inspect the Disc Mulcher by performing a walk around daily before and after use. Use the following inspection checklist as a guideline.

- After the Disc Mulcher has been attached, check that all latches or locks are closed.
- Check that all hydraulic fittings are tight and free of leaks.
- Check that all hydraulic lines are free of leaks, holes, or cracks. Replace as required.
- Check all hardware connections to the carrier machine for damage or fatigue such as cracks or other structural flaws.
- Inspect teeth and bolts for wear or damage
- Inspect all drive train bolts (motor, mount, housing, and teeth) for loosening. Tighten as needed.
- Check for wire or debris under the deck, remove any present.
- Clean debris from the motor area.
- Check that all guards and safety equipment are in good condition.

## Weekly Inspection

- Check teeth bolts for tightness
- Check all other bolts for tightness.
- Inspect the deck for cracks, bends, or damage.
- Inspect side plates and discharge chute for any damage.

## Monthly Inspection

- Inspect the entire drive system, including motor, and bearing housing.
- Inspect the teeth for cracks, bends, or excessive wear.
- Check skid plates for wear.
- Inspect the bolts on the motor. Tighten if required.
- Check that all bolts are tight.

## Inspection Checklist

- Are all safety notices and warning stickers in proper locations and visible?
- Are all safety guards properly installed and in good condition?
- Are there any visible hydraulic leaks?
- Is there any wire or vines wound under the deck?
- Are any cracks visible in Disc Mulcher structure?
- Are the teeth worn, bent, or broken?
- Has all debris been removed from the motor area?
- Has the carrier machine been properly inspected for hydraulic leaks and proper tire inflation?
  
- Has the carrier machine been properly maintained?

# DISC MULCHER - PARTS BREAKDOWN

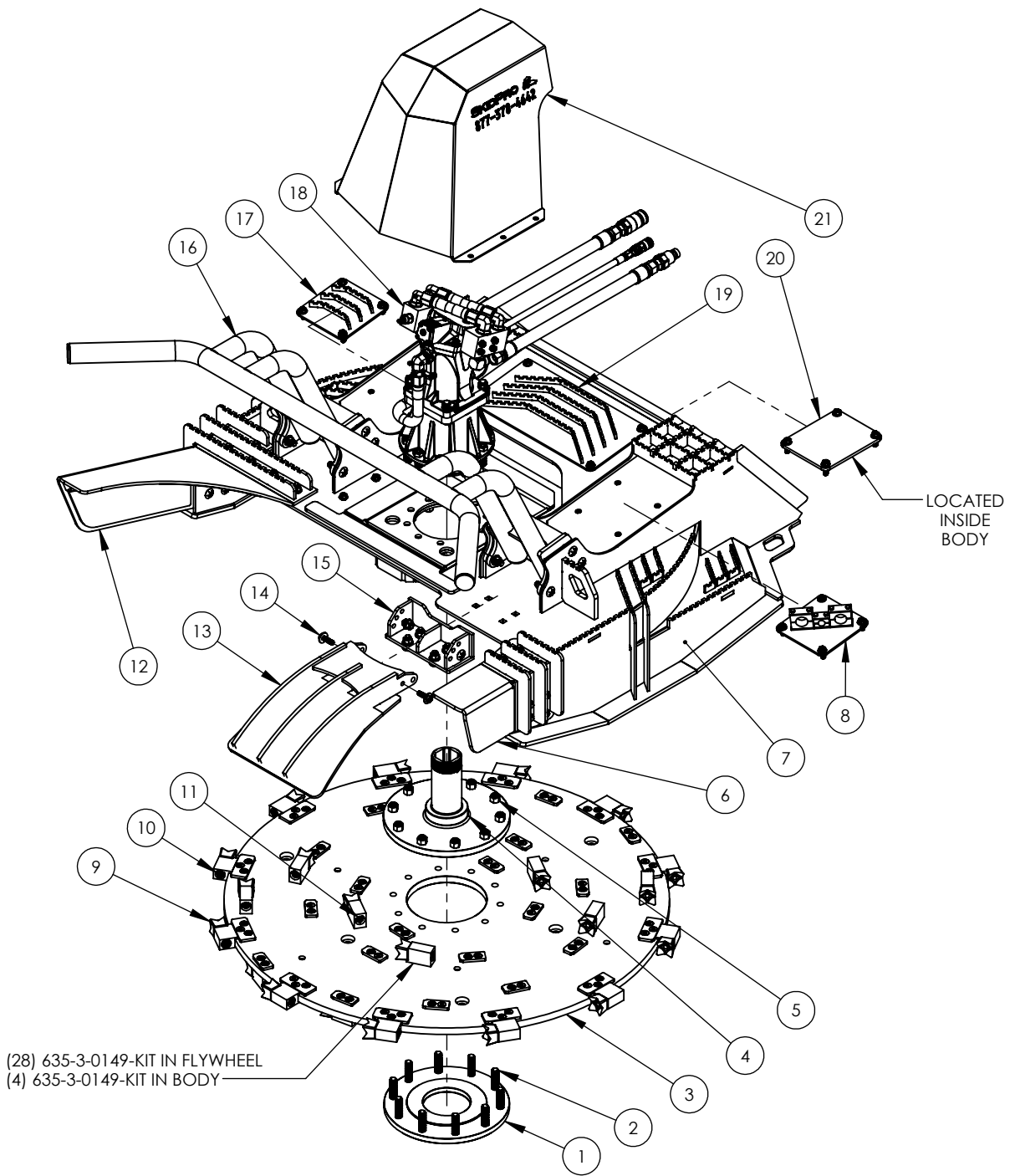

## DISC MULCHER - PARTS BREAKDOWN

ITEM NO.	PART NUMBER	DESCRIPTION	QTY.
1	635-3-0066	BOLT PLATE	1
2	HW-.750-16X3.0G8TB	3/4"-16X3" G8 TAP BOLT	10
3	635-2-0002	BALANCED - FLY WHEEL SUB ASM	1
4	635-2-0025	MULCHER SPINDLE SHAFT	1
5	HW-.750-16NYLG8	3/4"-16 NYLOCK NUT G8	20
6	635-2-0103	DISCHARGE ASM	1
7	635-2-0001	DISC MULCHER BODY	1
8	635-2-0109	SIDE COVER W/ HOSE CLAMP	1
9	635-3-0053-KIT	HIGH SPEED STEEL TOOTH KIT	44
10	635-3-0148-KIT	O.D. TOOL HOLDER KIT	12
11	635-3-0149-KIT	TOOL HOLDER KIT	32
12	635-2-0102	INTAKE ASM	1
13	635-2-0105	FLAP ASM	1
14	HW-.500-13X1.75G5	1/2"-13 X 1-3/4" GRADE 5 BOLT	2
15	635-2-0104	HINGE ASM	1
16	635-2-0107	PUSH BAR	1
17	635-2-0108	SIDE COVER W/ STEP	1
18	DRIVE ASSEMBLY	PISTON MOTOR	1
19	635-2-0106	CENTER COVER W/ STEP	1
20	635-3-0156	ACCESS COVER	1
21	635-2-0007	DISC MULCHER HOOD	1

## DISC MULCHER - REPLACEMENT DECALS

DECAL NO.	PART NUMBER	DESCRIPTION	QTY.
1	DECAL-3-0004	3X10 "WARNING"	2
2	DECAL-3-0006	2.250X10 "DANGER"	2
3	DECAL-3-0008	3X5 "HIGH PRESSURE FLUID"	1
4	DECAL-3-0009	3X3 "READ OWNERS MANUAL"	1
5	DECAL-3-0074	YELLOW "CAUTION DO NOT OPERATE"	1
6	DECAL-3-0182	635-1-0001 SERIAL#	1

# DRIVE ASSEMBLY - PARTS BREAKDOWN

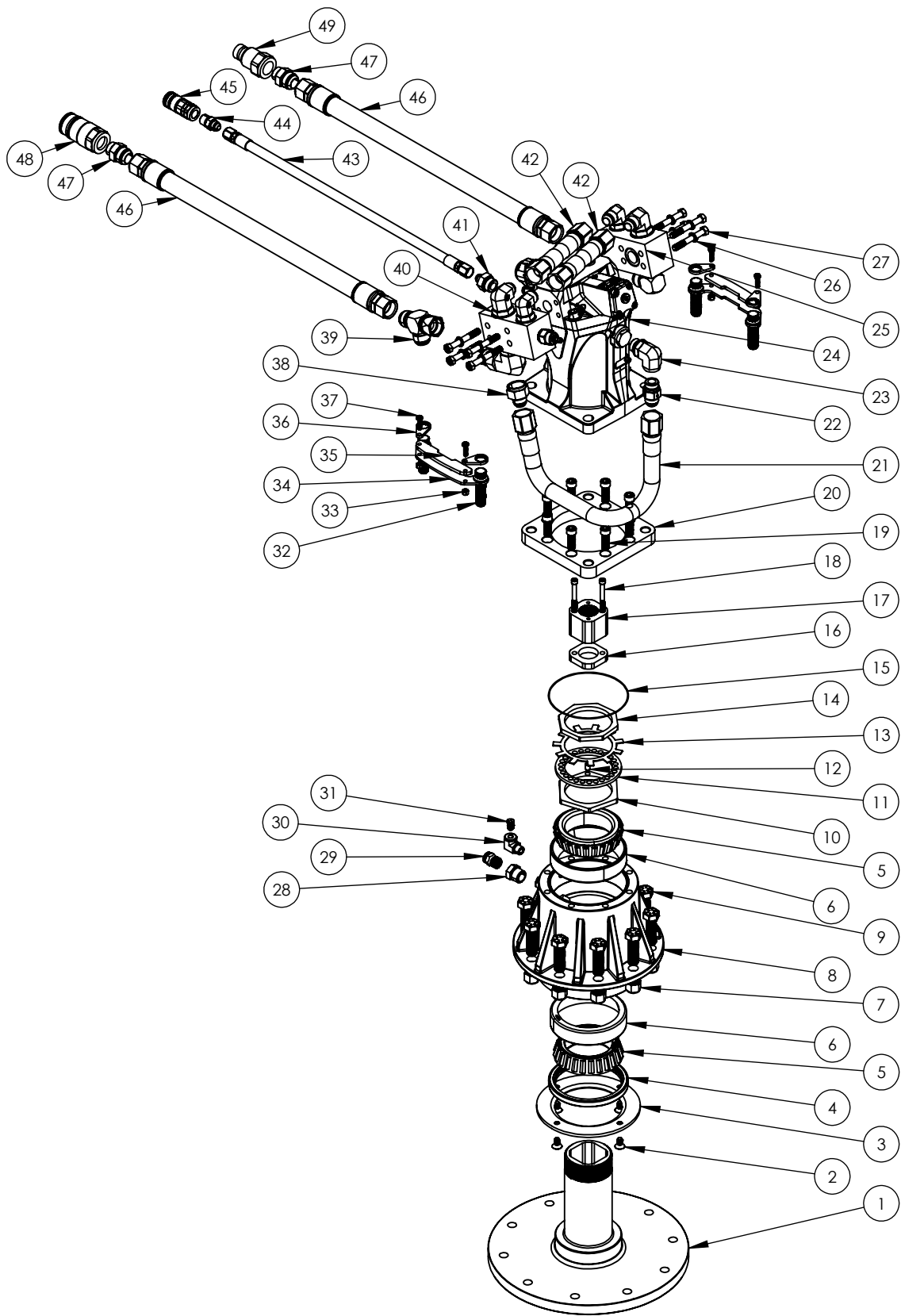

## DRIVE ASSEMBLY - PARTS BREAKDOWN

ITEM NO.	PART NUMBER	DESCRIPTION	QTY.
1	635-2-0025	MULCHER SPINDLE SHAFT	1
2	HW-.375-16X.75FS	3/8"-16 X 3/4" FLAT HEAD CAP SCREW	4
3	612-3-0063-2	SEAL PROTECTION	1
4	RTD-52625TA-H	OIL SEAL	1
5	612-3-0054-2	594A TAPERED BEARING	2
6	612-3-0053-2	592 TAPERED BEARING RACE	2
7	HW-.750-16NYLG8	3/4"-16 NYLOCK NUT G8	10
8	612-2-0024	BEARING HOUSING	1
9	HW-.750-16X2.5G8TB	3/4"-16X2-1/2" G8 TAP BOLT	10
10	612-3-0096-2	LOCK NUT	1
11	612-3-0050-2	LOCK NUT RETAINER	1
12	HW-.375X.50DOWEL	3/8" X 1/2" DOWEL PIN	1
13	612-3-0051-2	JAM NUT RETAINER	1
14	612-3-0095-2	JAM NUT	1
15	612-3-0133	ORING (BEARING HOUSING TO MOTOR PLATE)	1
16	635-3-0060	HUB SPACER	1
17	612-3-0110	HUB, HIGH FLOW	1
18	HW-.312-24X2.75CS	5/16"-16 X 2-3/4" SOCKET HEAD CAP SCREW	2
19	HW-.500-20X1.5CS	1/2"-20 X 1-1/2" SOCKET HEAD CAP SCREW	8
20	635-3-0058	HF MOTOR MOUNTING PLATE	1
21	H750-22-12J12J	3/4" X 22" HOSE -12FJX -12FJX	1
22	H-1112R	CHECK INLINE -12MJIC X -12 MB	1
23	H-6815-12-12	-12 MORB X -12 FORB 90 DEG	1
24	635-3-1101	MOTOR 115-85CC	1
25	H-240718-LHASM	PM RELIEF BLOCK LH	1
26	HW-.438LWG8	7/16" LOCK WASHER G8	8
27	HW-.438-14X3.25G8	7/16"-14X3-1/4" GRADE 8	8
28	H750-5406-12-08	3/4 MNPT X 1/2 FNPT BUSHING	1
29	H500-H1820	HD BUTTON HEAD GREASE FITTING	1
30	H375-5502-06-02	3/8 MNPT X 1/8 FNPT 90 DEG	1
31	H125-A321620	1/8 NPT STRAIGHT BREATHER	1
32	HW-.75-16X2.5FC	ALLOY-STEEL 12-POINT SCREW	4
33	HW-.25-20NYL	1/4"-20 NYLOCK NUT	4
34	635-3-0062	BOLT RETAINER BASE	2
35	635-3-0063	BOLT RETAINER SPACER	2
36	635-3-0064	BOLT RETAINER TAB	4
37	HW-.25-20X1.0G5	1/4"-20X1" GRADE 5 BOLT	4
38	H-2406-16-12	-16 FJIC X -12 MJIC	1
39	H-6602-16-16-16	-16 MJIC -16 FJIC -16 MJIC TEE	1
40	H-240718-RHASM	PM RELIEF BLOCK RH	1
41	H500-FT21-08-12	8 MALE JIC TO 12 MALE ORB	1
42	H750-D12S	3/4" CRIMP TO -12 JIC FEMALE	6
43	H500-ACC114-8	HOSE 1/2" X 114" -8FJX -8FJX	1
44	H-2404-8-8	-8 MJIC X -8 MNPT ADAPTER	1
45	H375-FT24-8	3/8" FEMALE CASE DRAIN COUPLER	1
46	H1000-106-16FJX	HOSE 1" X 106" -16FJX -16FJX	2
47	H-6400-16-12	-16 MJIC X -12 MORB ADAPTER	2
48	AU-03-9990-12-34	3/4" FEMALE COUPLER	1
49	AU-03-9991-12-34	3/4" MALE COUPLER	1

# PM RELIEF BLOCK RH - PARTS BREAKDOWN

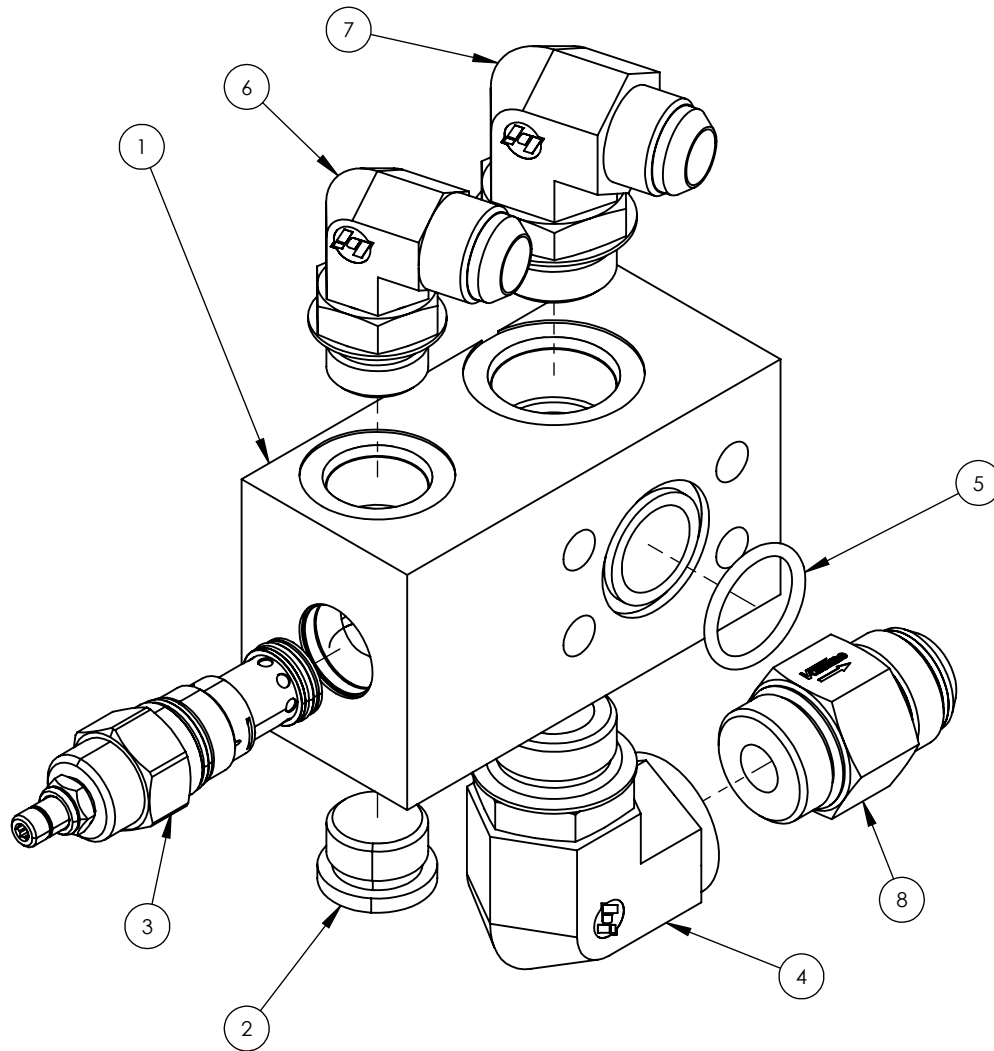

ITEM NO.	PART NUMBER	DESCRIPTION	QTY.
1	H-240718	PM RELIEF BLOCK	1
2	H-6409-12	-12 MORB PLUG	1
3	H-RPGCLWN-1750	-1750 PSI RELIEF X SUN T-3A	1
4	H-6815-16-16	-16 MORB ADJ X -16 FORB 90	1
5	O-RINGSAE-219	O-RINGSAE-219 90A	1
6	H750-FT22-12-12	12 MALE ORB TO 12 JIC MALE 90	1
7	H750-FT22-16-12	12JICM-16ORB M 90DEG	1
8	H-1116R	CHECK INLINE 16MJIC-16MB	1

# PM RELIEF BLOCK LH - PARTS BREAKDOWN

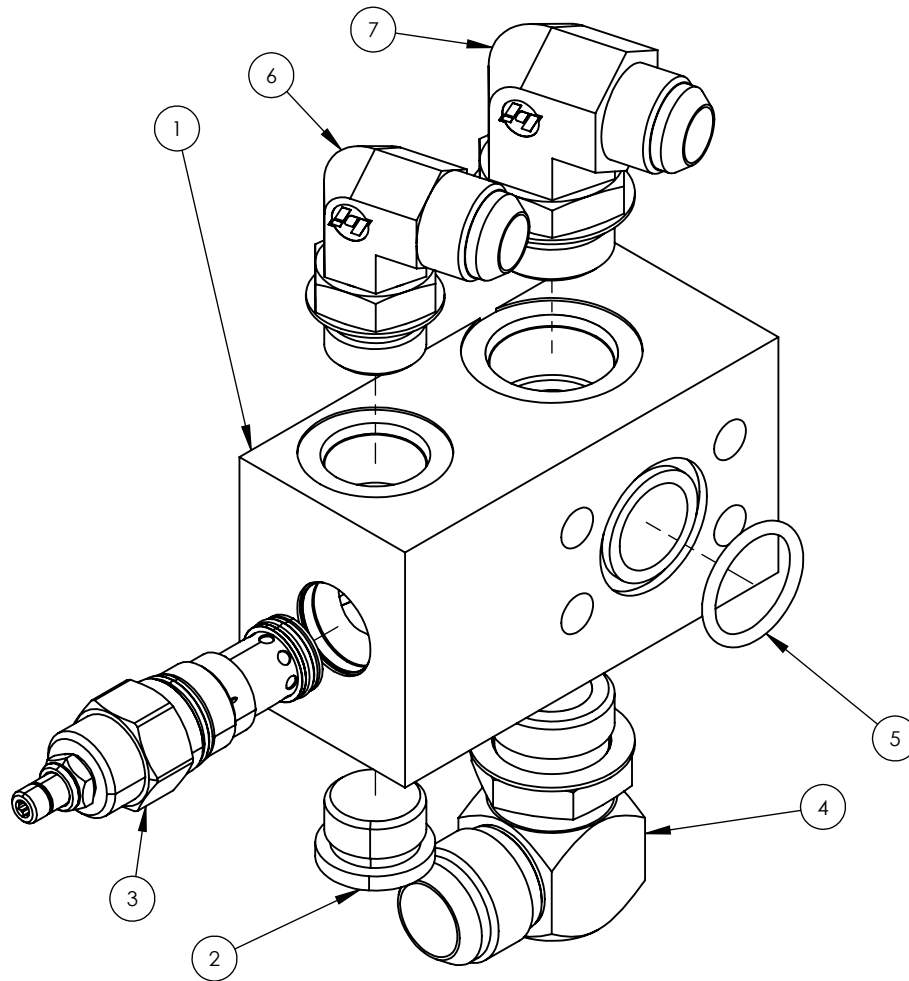

ITEM NO.	PART NUMBER	DESCRIPTION	QTY.
1	H-240718	PM RELIEF BLOCK	1
2	H-6409-12	-12 MORB PLUG	1
3	H-RPGCLWN-4500	-4500 PSI RELIEF X SUN T-3A	1
4	H-6801-16-16	16 JICM-16ORBM 90DEG	1
5	O-RINGSAE-219	O-RINGSAE-219 90A	1
6	H750-FT22-12-12	12 MALE ORB TO 12 JIC MALE 90	1
7	H750-FT22-16-12	12JICM-16ORBM 90DEG	1

# TOOL HOLDERS AND MULCHER TEETH

## 635-3-0052-KIT CARBIDE TOOTH KIT (ALTERNATE OPTION)

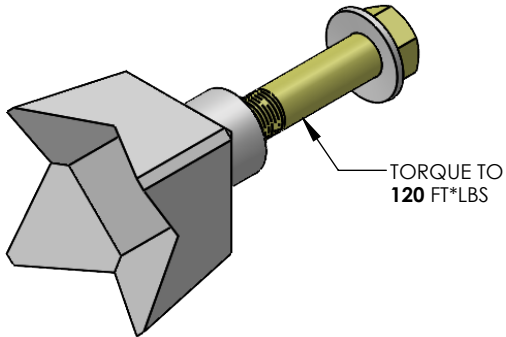

ITEM NO.	PART NUMBER	DESCRIPTION	QTY.
1	635-3-0052	MULCHER TOOTH - CARBIDE	1
2	HW-.500-20X2.75G8	1/2"-20X2-3/4" HH G8	1
3	HW-.500SPRING-LW	1/2" SPRING LOCK WASHER	1

## 635-3-0053-KIT HIGH SPEED STEEL TOOTH KIT (STANDARD OPTION)

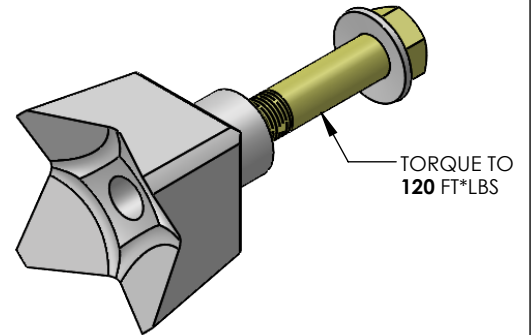

ITEM NO.	PART NUMBER	DESCRIPTION	QTY.
1	635-3-0053	MULCHER TOOTH - HSS	1
2	HW-.500-20X2.75G8	1/2"-20X2-3/4" HH G8	1
3	HW-.500SPRING-LW	1/2" SPRING LOCK WASHER	1

## 635-3-0148-KIT O.D. TOOL HOLDER KIT

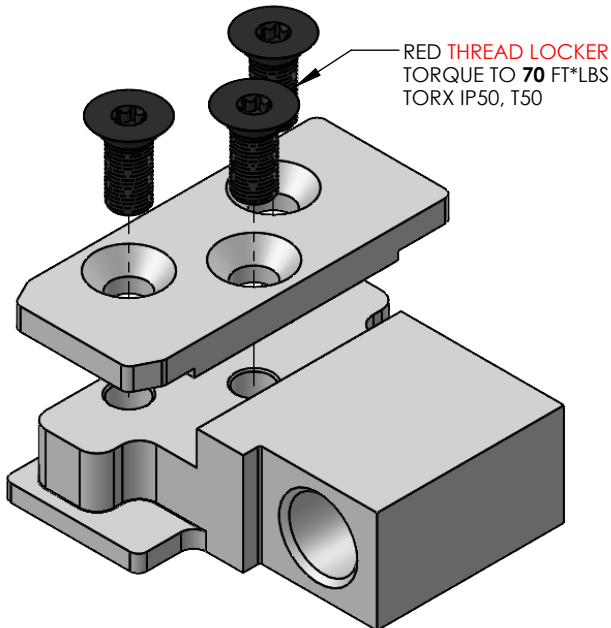

ITEM NO.	PART NUMBER	DESCRIPTION	QTY.
1	635-3-0148	O.D. TOOL HOLDER - BOLT ON	1
2	635-3-0151	O.D. TOOL HOLDER CAP	1
3	HW-.500-20X1.125FHTS	1/2-20X1-1/8 FLAT TORX SCREW	3

## 635-3-0149-KIT TOOL HOLDER KIT

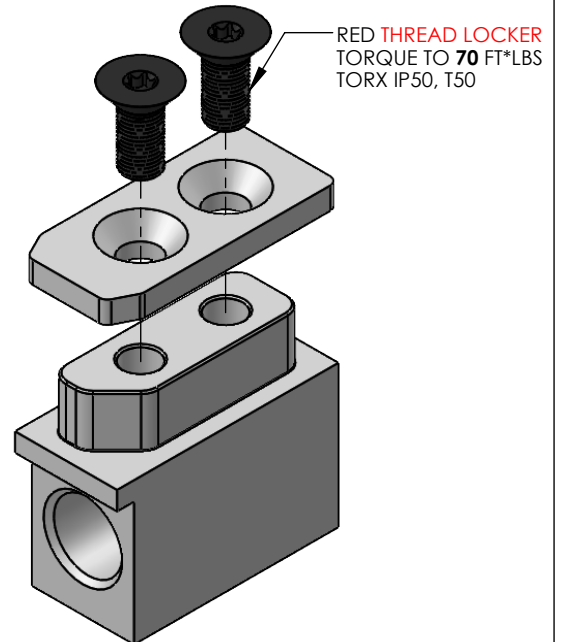

ITEM NO.	PART NUMBER	DESCRIPTION	QTY.
1	635-3-0149	TOOL HOLDER - BOLT ON	1
2	635-3-0150	TOOL HOLDER CAP	1
3	HW-.500-20X1.125FHTS	1/2-20X1-1/8 FLAT TORX SCREW	2

## **SKID PRO ATTACHMENT WARRANTY**

**Attachments covered under this 24 Month Warranty include:**

**Angle Broom; Backhoe; Disc Mulcher; Industrial Brush Cutters: Close Front, Open Front, Open Front High Flow; Dozer Blade; 84” Industrial Grapple Rake; 72” Grapple Rake; Land Leveler; Pallet Forks; Skid Hitch; Snow Blade; Snow Blower; Soil Conditioner; Stump Bucket; Tiller; Tree Shear;**

Skid Pro warrants above attachments for twenty-four months from date of shipment, to the original owner. Warranty covers products to be free from defects in material and workmanship when properly set up and operated in accordance with Skid Pro’s recommendations.

### **WARRANTY CLAIM PROCEDURE**

All warranty claims must be submitted within the manufacturer’s limited warranty period. Pictures and/or a video of the failing component(s) are required to properly document all potential warranty claims. To submit a warranty claim, contact your Skid Pro Product Guru or complete a [Warranty Claim Form](#) on our website and send it along with supporting pictures/video to [sales@skidpro.com](mailto:sales@skidpro.com). Upon receipt, the warranty claim information will be reviewed and once determined to be a valid claim, a return authorization number will be issued for the return of the defective part(s) if applicable and replacement part(s) will be shipped. If it is determined the defective parts are to be returned and they are not received by Skid Pro within 30 days of receiving the replacement parts, the Buyer will be charged for the cost of the replacement parts plus any shipping charges. Tampering with the failed part (i.e. disassembling a motor or cylinder) will void the warranty.

### **EXCLUSIONS OF WARRANTY**

Skid Pro’s requirement for any issue with respect to attachments shall be limited to repairing or replacing the defective part, as this is a parts-only warranty and does not include any labor to replace or install the part or downtime from resulting issue. Skid Pro has full technical support & assistance to assure customer replaces the part properly for optimal performance on attachment.

This warranty shall not apply to any attachment’s wear items, or attachments that have been repaired or altered outside the Skid Pro factory in any way, or that has been subject to misuse, negligence or accident beyond Skid Pro’s recommended use and/or machine rated capacity.

This warranty is exclusive and in lieu of all other warranties and conditions. Skid Pro disclaims all other warranties and conditions, express or implied, including any implied warranties or conditions of merchantability or fitness for a particular purpose. In no event shall Skid Pro be liable for any special, incidental, indirect or consequential damage, whatsoever, including, but not limited to, loss or interruption of business, lost profits, or loss of machine use, whether based on contract, warranty, tort, negligence, strict liability, statute or otherwise, even if Skid Pro has been advised of the possibility of such damages.

No agent, employee, or representative of Skid Pro has any authority to bind said company to any affirmation, representation, or warranty concerning its machinery and/or attachments except as specifically set forth herein. Any disagreement or dispute of warranty policy or customer expectations of product, soundness, functionality, or performance would take place in Douglas County, Alexandria, MN, where Skid Pro operates.



**PO BOX 982  
Alexandria, MN 56308**

**Phone: 877-378-4642  
FAX: 320-759-1057  
[www.skidpro.com](http://www.skidpro.com)  
[sales@skidpro.com](mailto:sales@skidpro.com)**