

ITEM NO.	PART NUMBER	DESCRIPTION	QTY.
1	612-2-0006-3	BODY, CLOSED FRONT	1
2	DRIVE ASSEMBLY	HIGH FLOW	1
3	612-2-0008-2	WIRE PROTECTION, UPPER	2
4	612-2-0012-3	FLYWHEEL ASSEMBLY	1
5	612-2-0011	CHAIN ROD	1
6	612-3-0045	DEBRIS CHAIN	46
7	612-3-0025	INSPECTION COVER	1
8	612-2-0042	CENTER STEP	1
9	612-2-0036	COVER, HIGH FLOW	1
10	612-3-0046	SAFETY CHAIN	1
11	612-3-0128	3/8 QUICK LINK	1
12	H750-HOSE CLAMP	TWIN HOSE CLAMP 3/4" HOSE	1
13	612-2-0013	3/4" X 108" HOSE	2
14	AU-03-9991-12-34	MALE QUICK COUPLER	1
15	AU-03-9990-12-34	FEMALE QUICK COUPLER	1
16	HSL750	HOSE SLEEVE	4 FT
17	612-2-0038	72 ROLLER (OPTIONAL)	1
18	612-3-0160	BEARING (OPTIONAL)	2

72" High Flow Industrial Open Front Brush Cutter

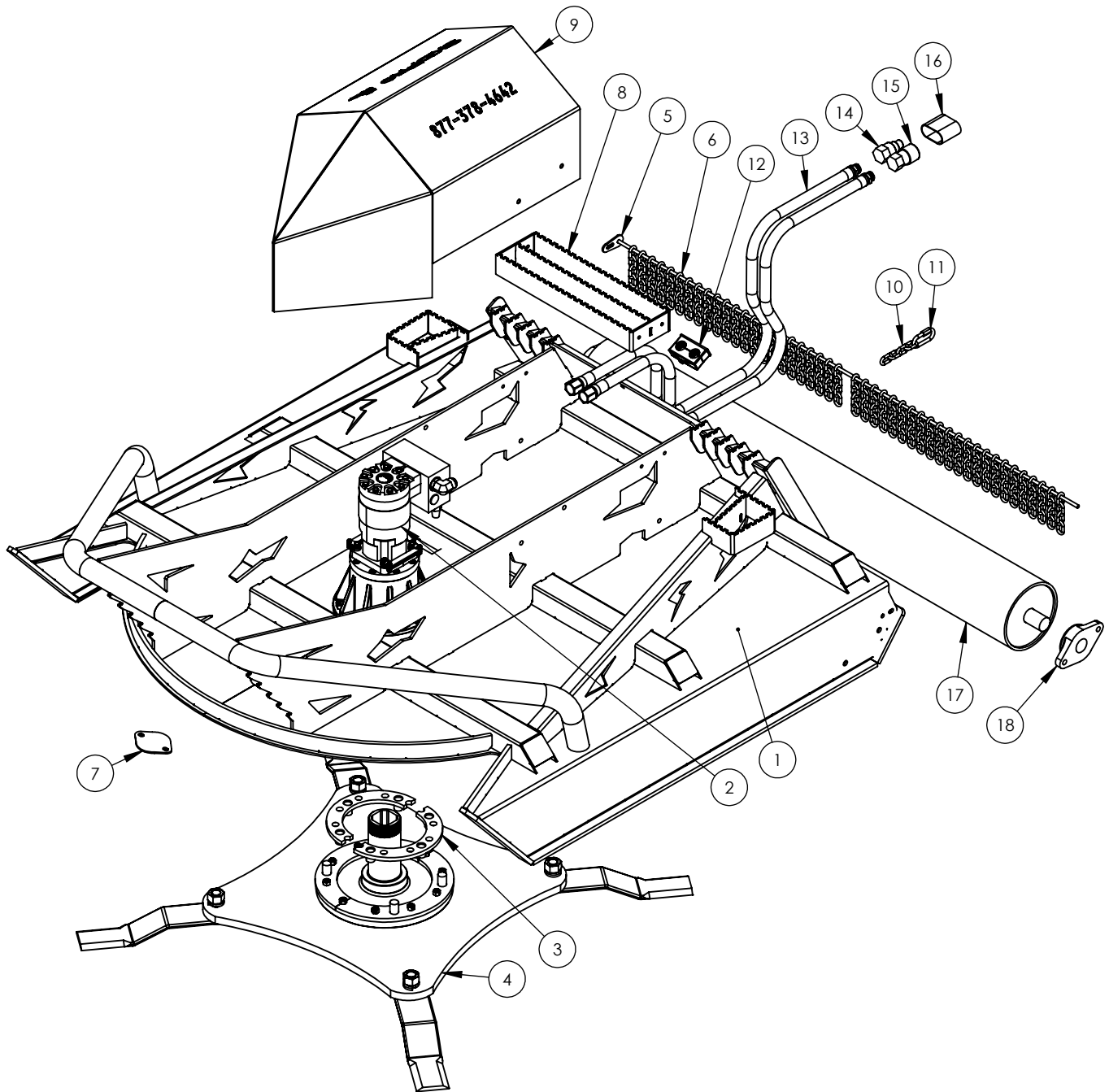

ITEM NO.	PART NUMBER	DESCRIPTION	QTY.
1	612-2-0020-3	BODY, OPEN FRONT	1
2	DRIVE ASSEMBLY	HIGH FLOW	1
3	612-2-0008-2	WIRE PROTECTION, UPPER	2
4	612-2-0012-3	FLYWHEEL ASSEMBLY	1
5	612-2-0011	CHAIN ROD	1
6	612-3-0045	DEBRIS CHAIN	46
7	612-3-0025	INSPECTION COVER	1
8	612-2-0042	CENTER STEP	1
9	612-2-0036	COVER, HIGH FLOW	1
10	612-3-0046	SAFETY CHAIN	1
11	612-3-0128	3/8 QUICK LINK	1
12	H750-HOSE CLAMP	TWIN HOSE CLAMP 3/4" HOSE	1
13	612-2-0013	3/4" X 108" HOSE	2
14	AU-03-9991-12-34	MALE QUICK COUPLER	1
15	AU-03-9990-12-34	FEMALE QUICK COUPLER	1
16	HSL750	HOSE SLEEVE	4 FT
17	612-2-0038	72 ROLLER (OPTIONAL)	1
18	612-3-0160	BEARING (OPTIONAL)	2

72" Standard Flow Industrial Closed Front Brush Cutter

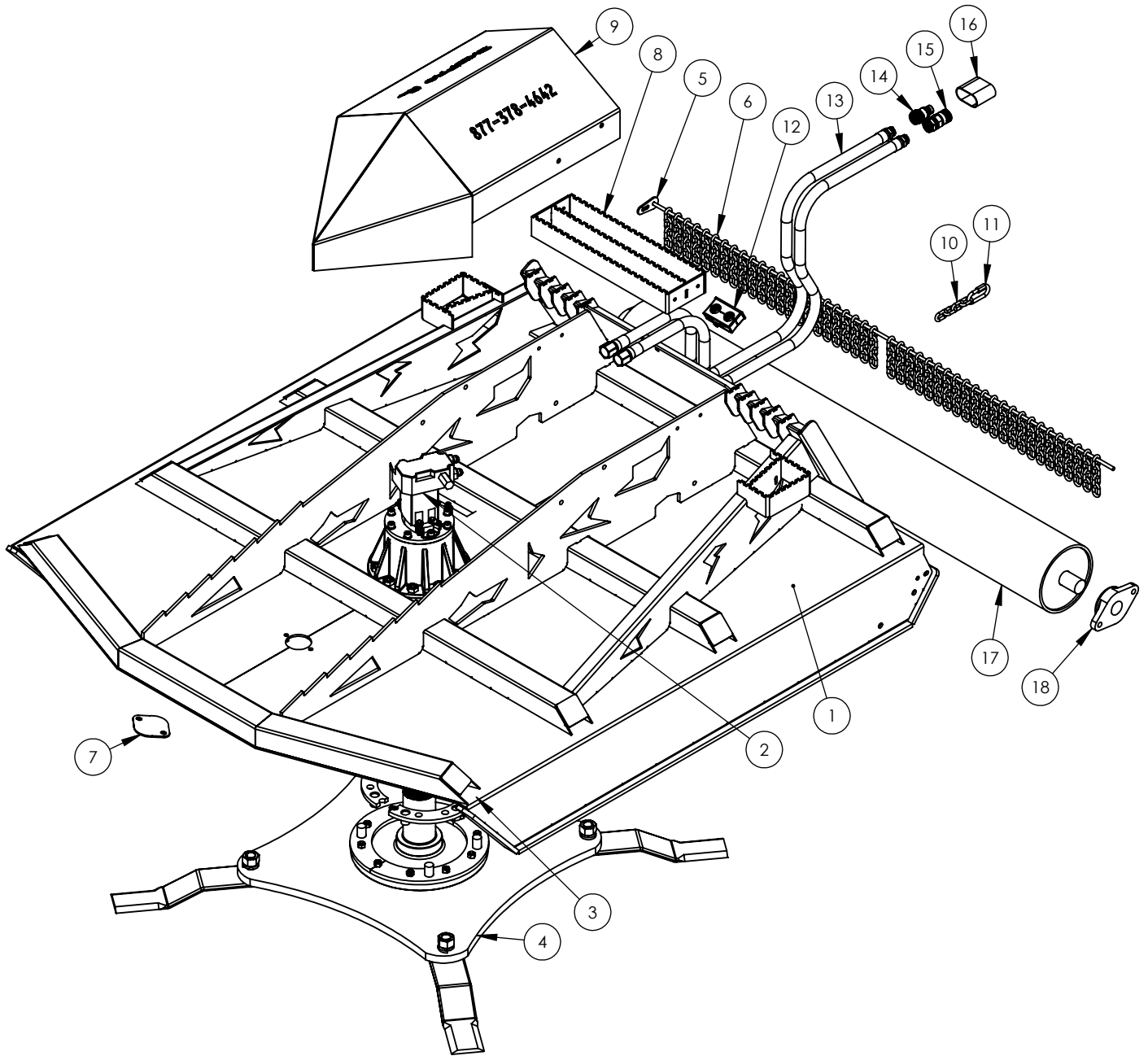

ITEM NO.	PART NUMBER	DESCRIPTION	QTY.
1	612-2-0006-3	BODY, CLOSED FRONT	1
2	DRIVE ASSEMBLY	STANDARD FLOW	1
3	612-2-0008-2	WIRE PROTECTION, UPPER	2
4	612-2-0012-3	FLYWHEEL ASSEMBLY	1
5	612-2-0011	CHAIN ROD	1
6	612-3-0045	DEBRIS CHAIN	46
7	612-3-0025	INSPECTION COVER	1
8	612-2-0042	CENTER STEP	1
9	612-2-0035	COVER, STANDARD FLOW	1
10	612-3-0046	SAFETY CHAIN	1
11	612-3-0128	3/8 QUICK LINK	1
12	H750-HOSE CLAMP	TWIN HOSE CLAMP 3/4" HOSE	1
13	612-2-0013	3/4" X 108" HOSE	2
14	AU-03-9991-12-12	1/2" MALE FLAT FACE COUPLER	1
15	AU-03-9990-12-12	1/2" FEMALE FLAT FACE COUPLER	1
16	HSL750	HOSE SLEEVE	4 FT
17	612-2-0038	72 ROLLER (OPTIONAL)	1
18	612-3-0160	BEARING (OPTIONAL)	2

72" Standard Flow Industrial Open Front Brush Cutter

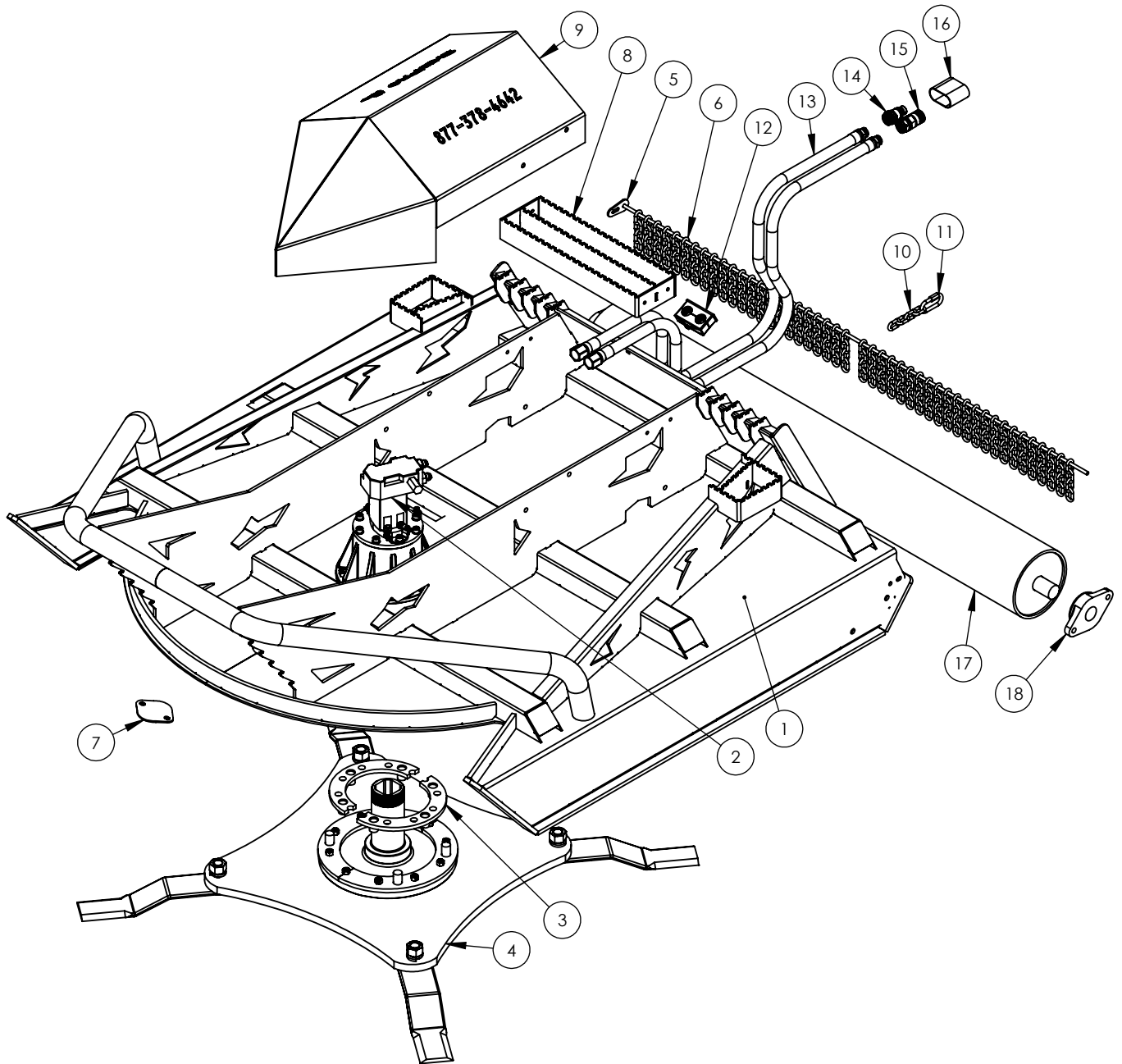

ITEM NO.	PART NUMBER	DESCRIPTION	QTY.
1	612-2-0020-3	BODY, OPEN FRONT	1
2	DRIVE ASSEMBLY	STANDARD FLOW	1
3	612-2-0008-2	WIRE PROTECTION, UPPER	2
4	612-2-0012-3	FLYWHEEL ASSEMBLY	1
5	612-2-0011	CHAIN ROD	1
6	612-3-0045	DEBRIS CHAIN	46
7	612-3-0025	INSPECTION COVER	1
8	612-2-0042	CENTER STEP	1
9	612-2-0035	COVER, STANDARD FLOW	1
10	612-3-0046	SAFETY CHAIN	1
11	612-3-0128	3/8 QUICK LINK	1
12	H750-HOSE CLAMP	TWIN HOSE CLAMP 3/4" HOSE	1
13	612-2-0013	3/4" X 108" HOSE	2
14	AU-03-9991-12-12	1/2" MALE FLAT FACE COUPLER	1
15	AU-03-9990-12-12	1/2" FEMALE FLAT FACE COUPLER	1
16	HSL750	HOSE SLEEVE	4 FT
17	612-2-0038	72 ROLLER (OPTIONAL)	1
18	612-3-0160	BEARING (OPTIONAL)	2

72" Industrial Brush Cutter Flywheel

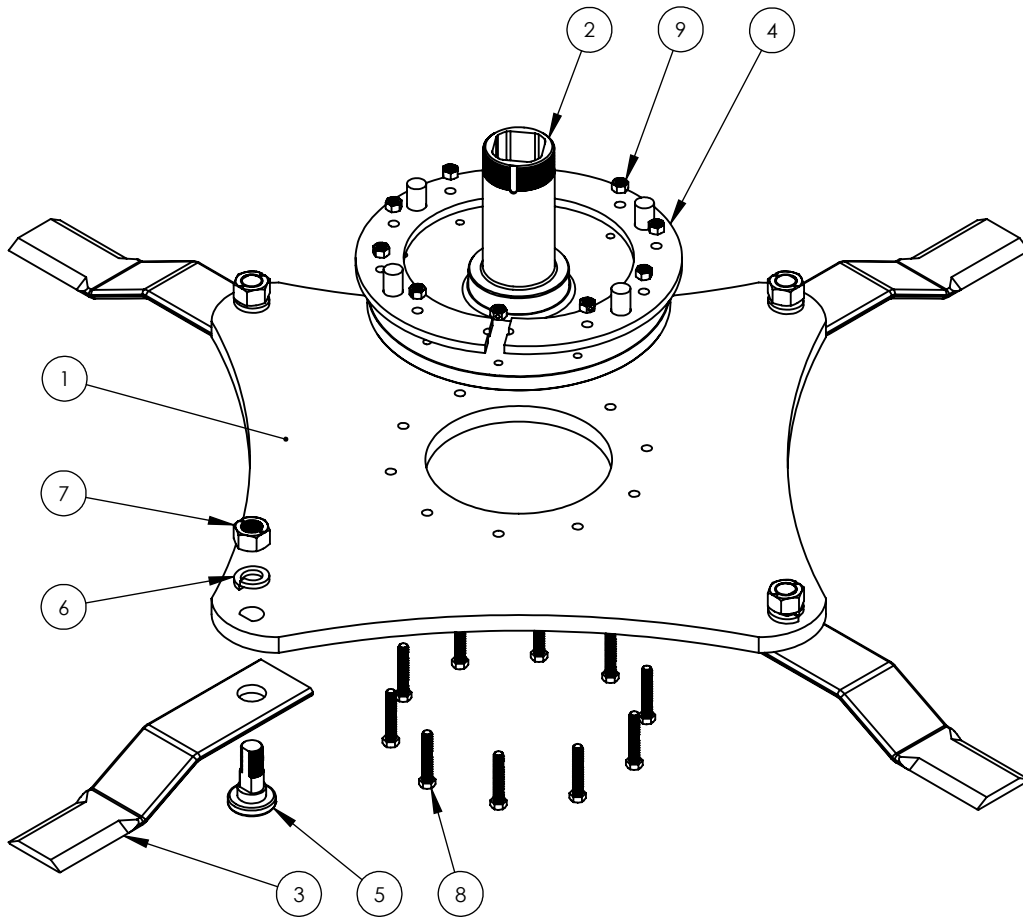

ITEM NO.	PART NUMBER	DESCRIPTION	QTY.
1	612-3-0147	FLYWHEEL PLATE	1
2	612-2-0025	MOWER SPINDLE SHAFT	1
3	612-3-0013	BLADE	4
4	612-2-0007-2	WIRE PROTECTION, LOWER	2
5	612-3-0048	BLADE BOLT	4
6	HW-1.125 LW	1-1/8" LOCK WASHER	4
7	HW-1.125-12 TLHN	1 1/8" -12 INTERNAL LOCKING NUT	4
8	HW-.500-13XG8TB	1/2"-13x3 HH TAP BOLT	10
9	HW-.500-13 RLN	1/2"-13 REVERSE LOCK NUT	10

72" Industrial Brush Cutter Decals

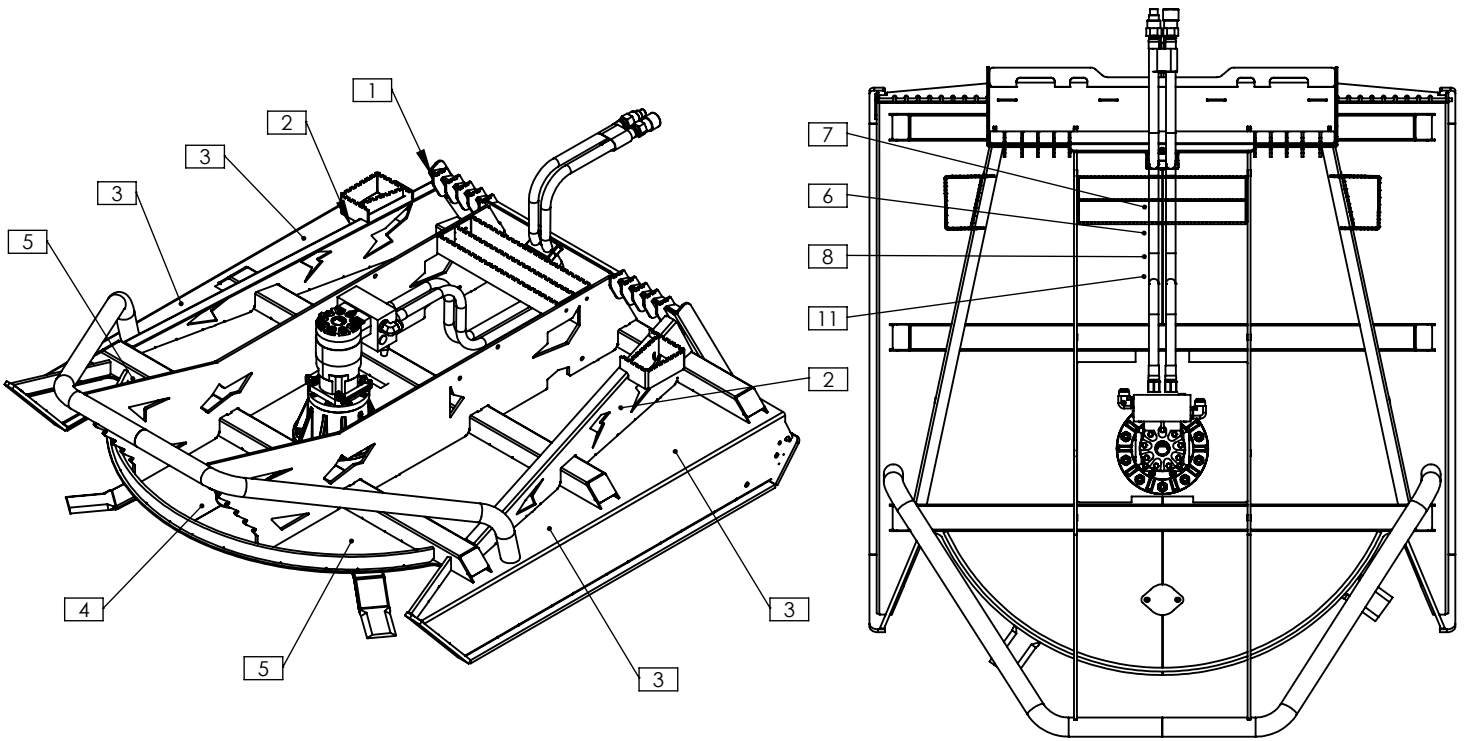

ITEM NO.	PART NUMBER	DESCRIPTION	QTY.
1	DECAL-3-XXXX	612-1-XXX SERIAL DECAL	1
2	DECAL-3-0003	4X5 "72" ORANGE & BLACK	2
*2	DECAL-3-0166	4X5 "84" ORANGE & BLACK	2
3	DECAL-3-0004	3X10 "WARNING	4
4	DECAL-3-0005	2.5X10 "SKID PRO" CLEAR BACK	1
5	DECAL-3-0006	2.25X10 "DANGER"	2
6	DECAL-3-0008	3X5 "HIGH PRESSURE FLUID"	1
7	DECAL-3-0009	3X3 "READ OWNERS MANUAL"	1
8	DECAL-3-0010	5X5 "DO NOT OPERATE WITHOUT SA	1
9	DECAL-3-0011	4X6 "CAUTION 25 GPM MAX"	1

STANDARD FLOW ONLY

84" High Flow Industrial Open Front Brush Cutter

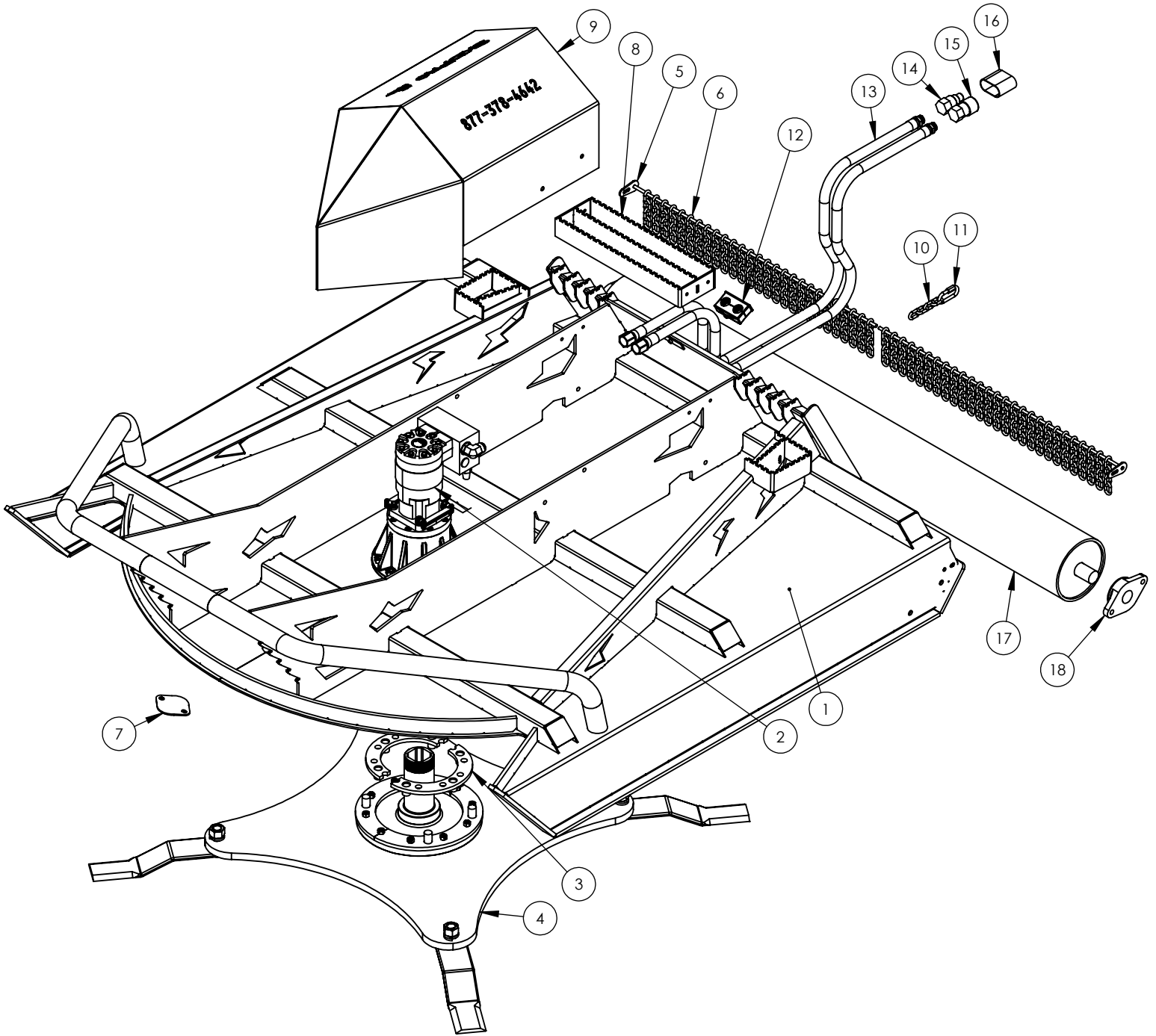

ITEM NO.	PART NUMBER	DESCRIPTION	QTY.
1	612-2-0020-84	84" BODY - OPEN FRONT	1
2	DRIVE ASSEMBLY	HIGH FLOW	1
*2	DRIVE ASSEMBLY	STANDARD FLOW (NOT PICTURED)	1
*2	DRIVE ASSEMBLY	PISTON MOTOR (NOT PICTURED)	1
3	612-2-0008-2	WIRE PROTECTION, UPPER	2
4	612-2-0012-84	84 FLYWHEEL ASSEMBLY	1
5	612-2-0011	CHAIN ROD - CUT	2
6	612-3-0045	DEBRIS CHAIN	54
7	612-3-0025	INSPECTION COVER	1
8	612-2-0042	CENTER STEP	1
9	612-2-0036	COVER, HIGH FLOW	1
*9	612-2-0035	COVER, STANDARD FLOW (NOT PICTURED)	1
10	612-3-0046	SAFETY CHAIN	1
11	612-3-0128	3/8 QUICK LINK	1
12	H750-HOSE CLAMP	TWIN HOSE CLAMP 3/4" HOSE	1
13	612-2-0314	3/4" X 114" HOSE	2
14	AU-03-9991-12-34	3/4" MALE FLAT FACE COUPLER (HIGH FLOW)	1
*14	AU-03-9991-12-12	1/2" MALE FLAT FACE COUPLER (STANDARD FLOW)	1
15	AU-03-9990-12-34	3/4" FEMALE FLAT FACE COUPLER (HIGH FLOW)	1
*15	AU-03-9990-12-12	1/2" FEMALE FLAT FACE COUPLER (STANDARD FLOW)	1
16	HSL750	HOSE SLEEVE	4.5 FT
17	612-2-0338	84 ROLLER (OPTIONAL)	1
18	612-3-0160	BEARING (OPTIONAL)	2
*DENOTES ALTERNATE OPTION - MACHINES CONFIGURED WITH PISTON MOTOR DO NOT INCLUDE ITEMS 13-16			

84" Standard Flow Industrial Open Front Brush Cutter

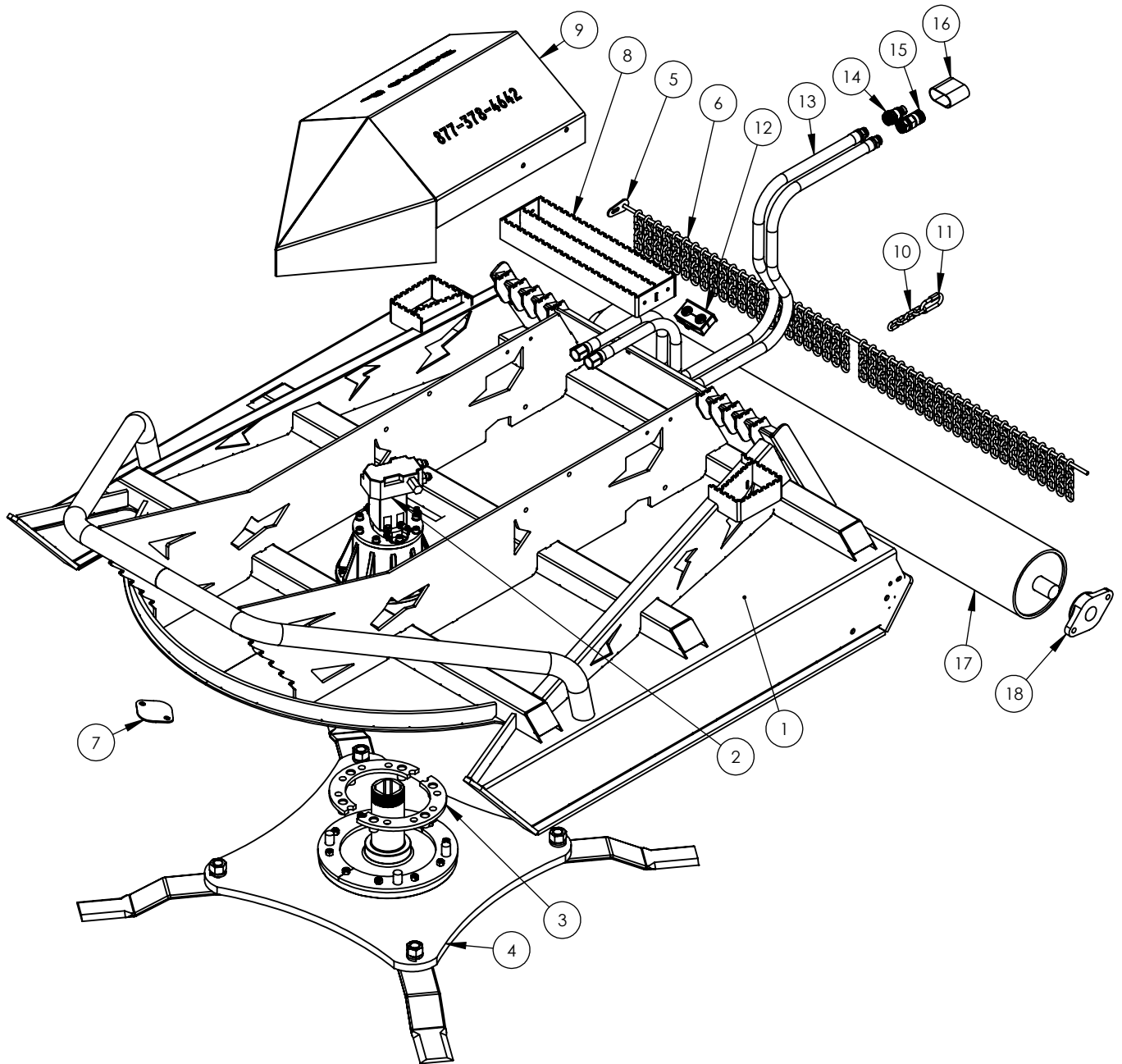

ITEM NO.	PART NUMBER	DESCRIPTION	QTY.
1	612-2-0020-3	BODY, OPEN FRONT	1
*1	612-2-0006-3	BODY, CLOSED FRONT (NOT PICTURED)	1
2	DRIVE ASSEMBLY	STANDARD FLOW	1
*2	DRIVE ASSEMBLY	HIGH FLOW (NOT PICTURED)	1
3	612-2-0008-2	WIRE PROTECTION, UPPER	2
4	612-2-0012-3	FLYWHEEL ASSEMBLY	1
5	612-2-0011	CHAIN ROD	1
6	612-3-0045	DEBRIS CHAIN	46
7	612-3-0025	INSPECTION COVER	1
8	612-2-0042	CENTER STEP	1
9	612-2-0035	COVER, STANDARD FLOW	1
*9	612-2-0036	COVER, HIGH FLOW (NOT PICTURED)	1
10	612-3-0046	SAFETY CHAIN	1
11	612-3-0128	3/8 QUICK LINK	1
12	H750-HOSE CLAMP	TWIN HOSE CLAMP 3/4" HOSE	1
13	612-2-0013	3/4" X 108" HOSE	2
14	AU-03-9991-12-12	1/2" MALE FLAT FACE COUPLER (STANDARD FLOW)	1
*14	AU-03-9991-12-34	3/4" MALE FLAT FACE COUPLER (HIGH FLOW)	1
15	AU-03-9990-12-12	1/2" FEMALE FLAT FACE COUPLER (STANDARD FLOW)	1
*15	AU-03-9990-12-34	3/4" FEMALE FLAT FACE COUPLER (HIGH FLOW)	1
16	HSL750	HOSE SLEEVE	4 FT
17	612-2-0038	72 ROLLER (OPTIONAL)	1
18	612-3-0160	BEARING (OPTIONAL)	2

*DENOTES ALTERNATE OPTION

84" Industrial Brush Cutter Flywheel

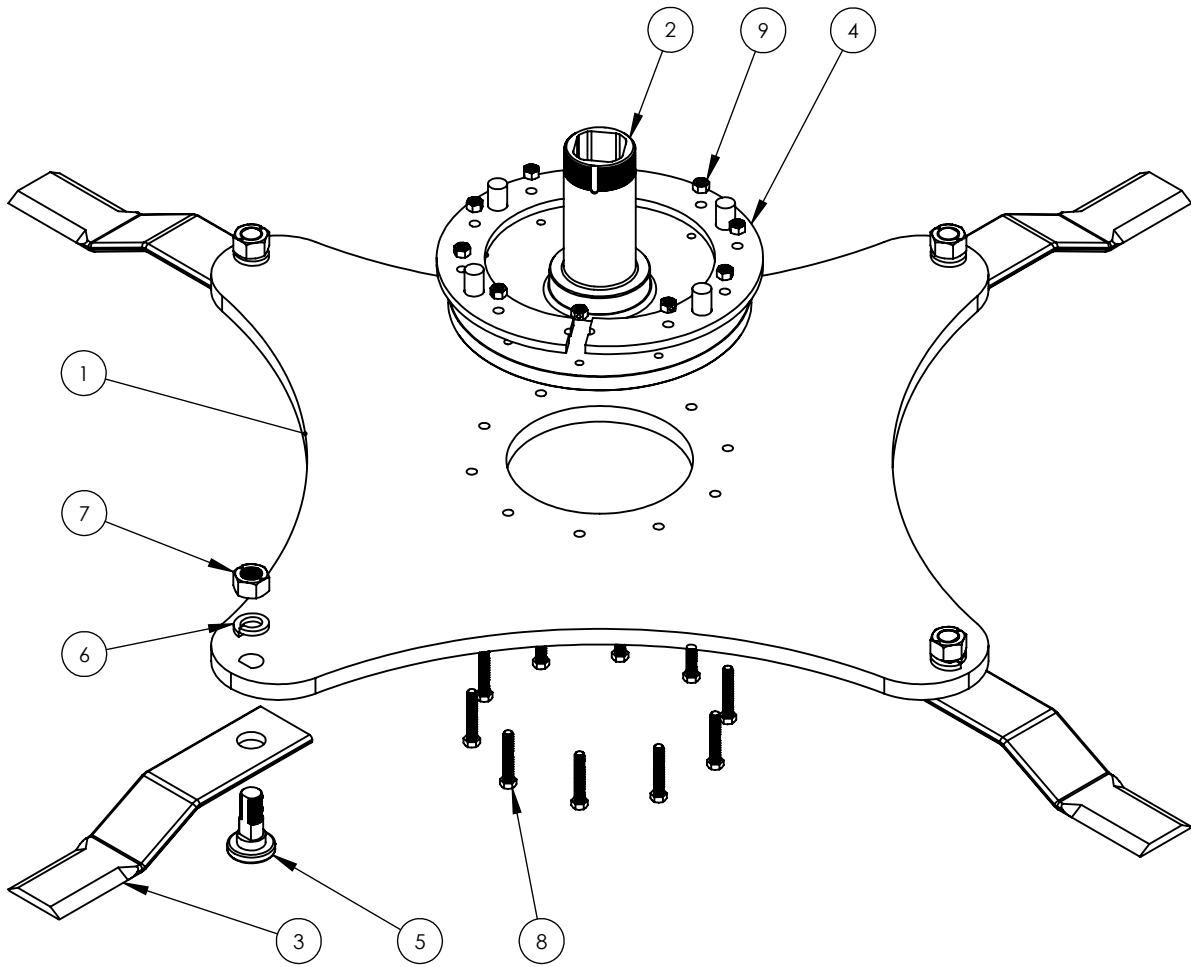

ITEM NO.	PART NUMBER	DESCRIPTION	QTY.
1	612-3-0312	84" 4-BLADE FLY WHEEL	1
2	612-2-0025	MOWER SPINDLE SHAFT	1
3	612-3-0013	BLADE	4
4	612-2-0007-2	WIRE PROTECTION, LOWER	2
5	612-3-0048	BLADE BOLT	4
6	HW-1.125 LW	1-1/8" LOCK WASHER	4
7	HW-1.125-12 TLHN	1 1/8" -12 INTERNAL LOCKING NUT	4
8	HW-.500-13XG8TB	1/2-13x3 HH TAP BOLT	10
9	HW-.500-13 RLN	1/2"-13 REVERSE LOCK NUT	10

84" Industrial Brush Cutter Decals

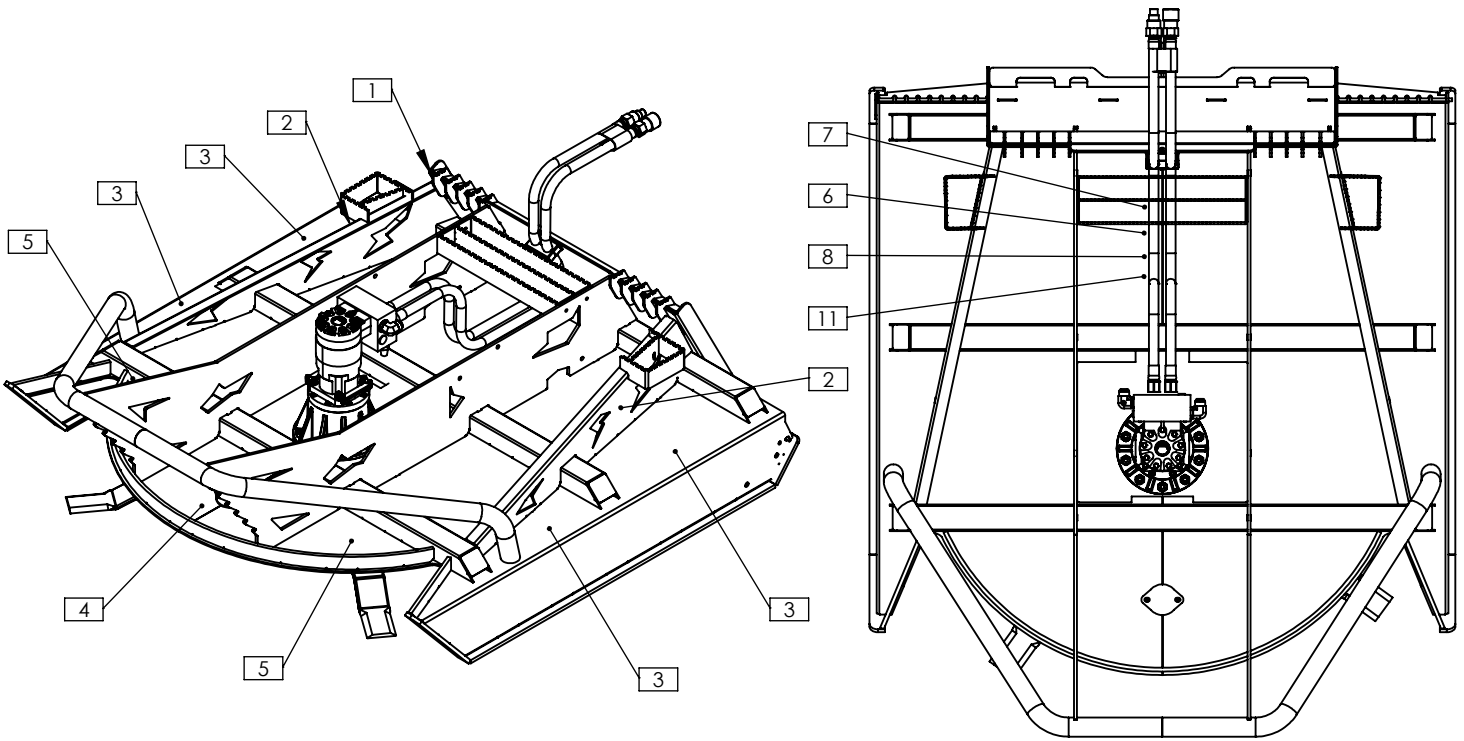

ITEM NO.	PART NUMBER	DESCRIPTION	QTY.
1	DECAL-3-XXXX	612-1-XXX SERIAL DECAL	1
2	DECAL-3-0003	4X5 "72" ORANGE & BLACK	2
*2	DECAL-3-0166	4X5 "84" ORANGE & BLACK	2
3	DECAL-3-0004	3X10 "WARNING"	4
4	DECAL-3-0005	2.5X10 "SKID PRO" CLEAR BACK	1
5	DECAL-3-0006	2.25X10 "DANGER"	2
6	DECAL-3-0008	3X5 "HIGH PRESSURE FLUID"	1
7	DECAL-3-0009	3X3 "READ OWNERS MANUAL"	1
8	DECAL-3-0010	5X5 "DO NOT OPERATE WITHOUT SA"	1
9	DECAL-3-0011	4X6 "CAUTION 25 GPM MAX"	1

STANDARD FLOW ONLY

Industrial Brush Cutter Drive Shaft

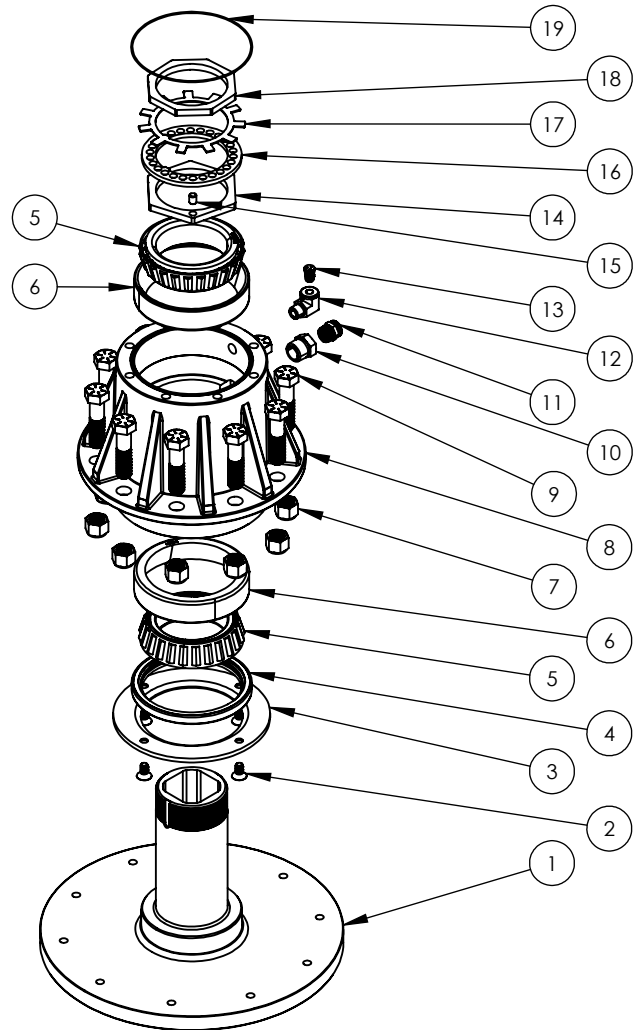
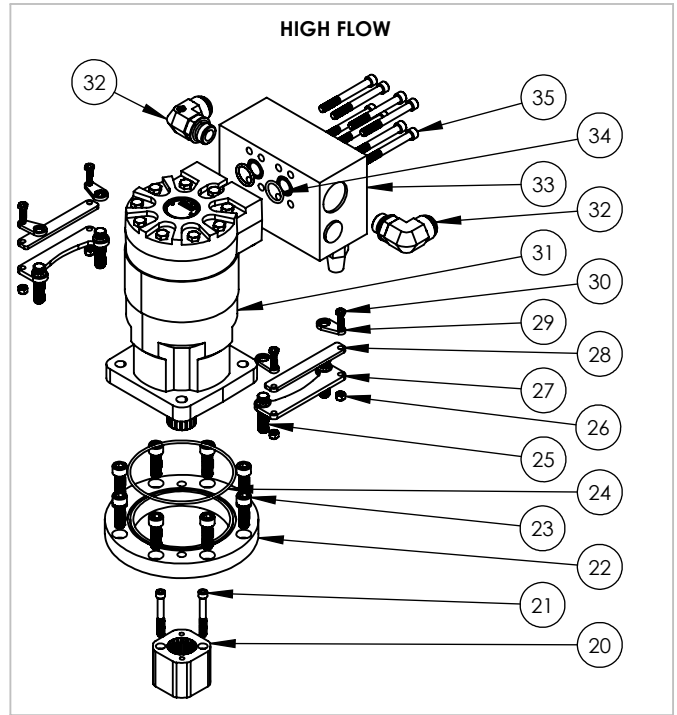
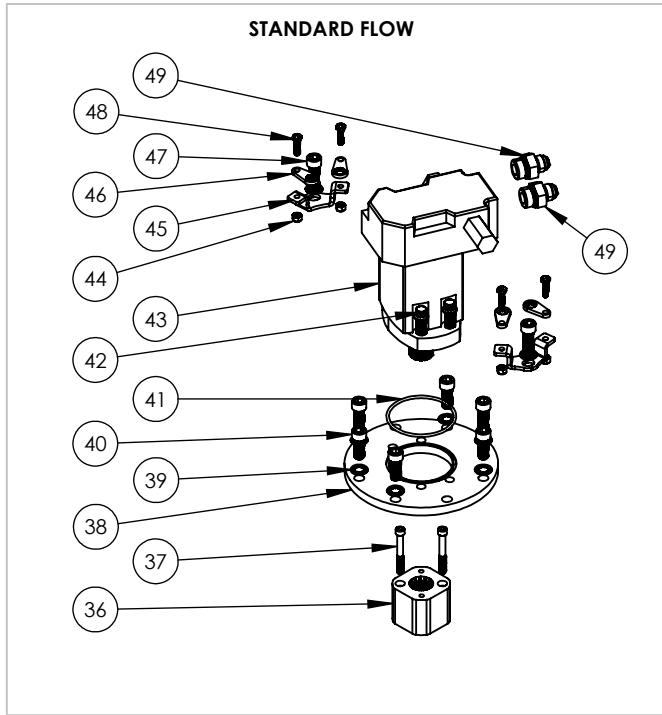

ITEM NO.	PART NUMBER	DESCRIPTION	QTY.
1	612-2-0025	MOWER SPINDLE SHAFT	1
2	HW-.375-16X.75 FS	3/8"-16 X 3/4" FLAT HEAD CAP SCREW	4
3	612-3-0063-2	SEAL PROTECTION	1
4	RTD-52625TA-H	OIL SEAL	1
5	612-3-0054-2	BEARING CONE	2
6	612-3-0053-2	BEARING RACE	2
7	HW-.750-16 NYL G8	3/4"-16 NYLOCK NUT	10
8	612-2-0024	BEARING HOUSING	1
9	HW-.750-16X3 G8	3/4"-16 X 3" GRADE 8 BOLT	10
10	H750-5406-12-08	3/4 MNPT X 1/2 FNPT BUSHING	1
11	H500-H1820	HD BUTTON HEAD GREASE FITTING	1
12	H375-5502-06-02	3/8 MNPT X 1/8 FNPT 90 DEG	1
13	H125-A321620	1/8 NPT STRAIGHT BREATHER	1
14	612-3-0096-2	LOCK NUT	1
15	HW-.375X.50 DP	3/8" X 1/2" DOWEL PIN	1
16	612-3-0050-2	LOCK NUT RETAINER	1
17	612-3-0051-2	JAM NUT RETAINER	1
18	612-3-0095-2	JAM NUT	1
19	612-3-0133	ORING (BEARING HOUSING TO MOTOR PLATE)	1

HIGH FLOW

ITEM NO.	PART NUMBER	DESCRIPTION	QTY.
20	612-3-0110	HUB, HIGH FLOW	1
21	HW-.312-24X2.5 CS	5/16"-16 X2 1/2" SOCKET HEAD CAP SCREW	2
22	612-3-0111	HF MOTOR MOUNTING PLATE	1
23	HW-.500-20X1.5CS	1/2"-20 X 1-1/2" SOCKET HEAD CAP SCREW	8
24	612-3-0134	ORING (HIGH FLOW MOTOR)	1
25	HW-.500-20X1.75FCS	1/2"-20 X 1 3/4" FERRY CAP SCREW	4
26	HW-.25-20 NYL	1/4"-20 NYLOCK NUT	4
27	612-3-0209	BOLT RETAINER BODY	2
28	612-3-0211	BOLT RETAINER SPACER	2
29	612-3-0210	BOLT RETAINER TAB	4
30	HW-.25-20X1.0G5	1/4"-20X1" GRADE 5 BOLT	4
31	612-3-0060-HF	MOTOR ASSM, HIGH FLOW	1
32	H750-FT22-16-12	16 MALE ORB TO 12 JIC MALE 90	2
33	AU-02-2052	RELEIF MANIFOLD ASSEMBLY, (HIGH FLOW ONLY)	1
34	214-90D	ORING, HF MOWER MANIFOLD	2
35	HW-.375-16X3.5 CS	3/8"-16 X 3 1/2" SOCKET HEAD CAP SCREW	8

STANDARD FLOW

ITEM NO.	PART NUMBER	DESCRIPTION	QTY.
36	612-3-0110-20	HUB, STANDARD FLOW	1
37	HW-.312-24X2.5 CS	5/16"-16 X2 1/2" SOCKET HEAD CAP SCREW	2
38	612-3-0111-20	MOTOR MOUNT PLATE STANDARD FLOW	1
39	HW-.500 INTLW	1/2" INTERNAL LOCK WASHER	8
40	HW-.500-20X1.25CS	1/2"-20 X 1 1/4" SOCKET HEAD CAP SCREW	6
41	612-3-0132	ORING (STANDARD FLOW MOTOR)	1
42	HW-.50-20X1.25FCS	1/2"-20 X 1-1/4" FERRY CAP SCREW	4
43	612-3-0060	MOTOR, STANDARD FLOW	1
44	HW-.500-20X1.5CS	1/2"-20 X 1-1/2" SOCKET HEAD CAP SCREW	2
45	612-3-0213	BOLT RETAINER BRACKET	2
46	HW-.25-20X1.0G5	1/4"-20X1" GRADE 5 BOLT	4
47	HW-.25-20 NYL	1/4"-20 NYLOCK NUT	4
48	612-3-0210	BOLT RETAINER TAB	4
49	H750-FT21-10-12	10 MALE ORB TO 12 FEMALE JIC	2

PISTON MOTOR

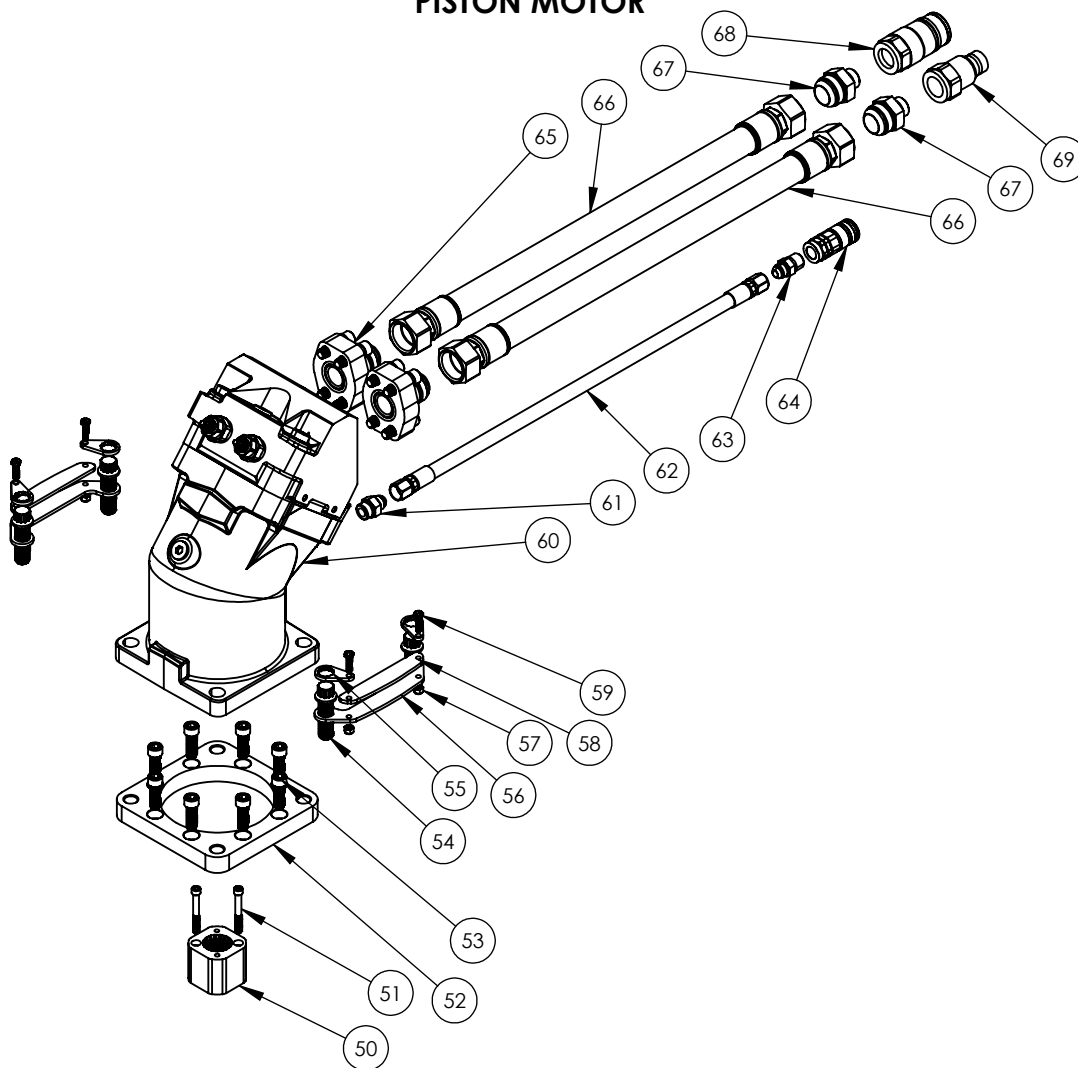

PISTON MOTOR

ITEM NO.	PART NUMBER	DESCRIPTION	QTY.
50	612-3-0110	HUB, HIGH FLOW	1
51	HW-.312-24X2.5 CS	5/16"-16 X2 1/2" SOCKET HEAD CAP SCREW	2
52	635-3-0058	HF MOTOR MOUNTING PLATE	1
53	HW-.500-20X1.5CS	1/2"-20 X 1-1/2" SOCKET HEAD CAP SCREW	8
54	HW-.750-16X2.5 FC	ALLOY-STEEL 12-POINT SCREW	4
55	635-3-0064	BOLT RETAINER TAB	4
56	635-3-0062	BOLT RETAINER BASE	2
57	HW-.25-20 NYL	1/4"-20 NYLOCK NUT	4
58	635-3-0063	BOLT RETAINER SPACER	2
59	HW-.25-20X1.0G5	1/4"-20X1" GRADE 5 BOLT	4
60	612-3-0318	180CC PISTON MTR W/4.5K RELIEF	1
61	H6400-08-10	-8 MJIC X -10 MORB ADAPTER	1
62	H500-ACC114-8	HOSE 1/2"X1 1/4" -8FJX-8FJX	1
63	H2404-8-8	-8 MJIC X -8 MNPT ADAPTER	1
64	H375-FT24-8	3/8" FEMALE CASE DRAIN COUPLER	1
65	W600-20-20U	-20 MJIC X C62 FLANGE KIT	2
66	H1000-ACC114-16	HOSE 1"X1 1/4"-20FJX-20FJX (WITH SLEEVE)	2
67	H1000-6400-20-12	-20 MJIC X -12 MORB (WITH SLEEVE)	2
68	AU-03-9990-12-34	3/4" FEMALE COUPLER	1
69	AU-03-9991-12-34	3/4" MALE COUPLER	1