

PARTS DIAGRAMS AND LISTS

Brush Cutter - Diagram A

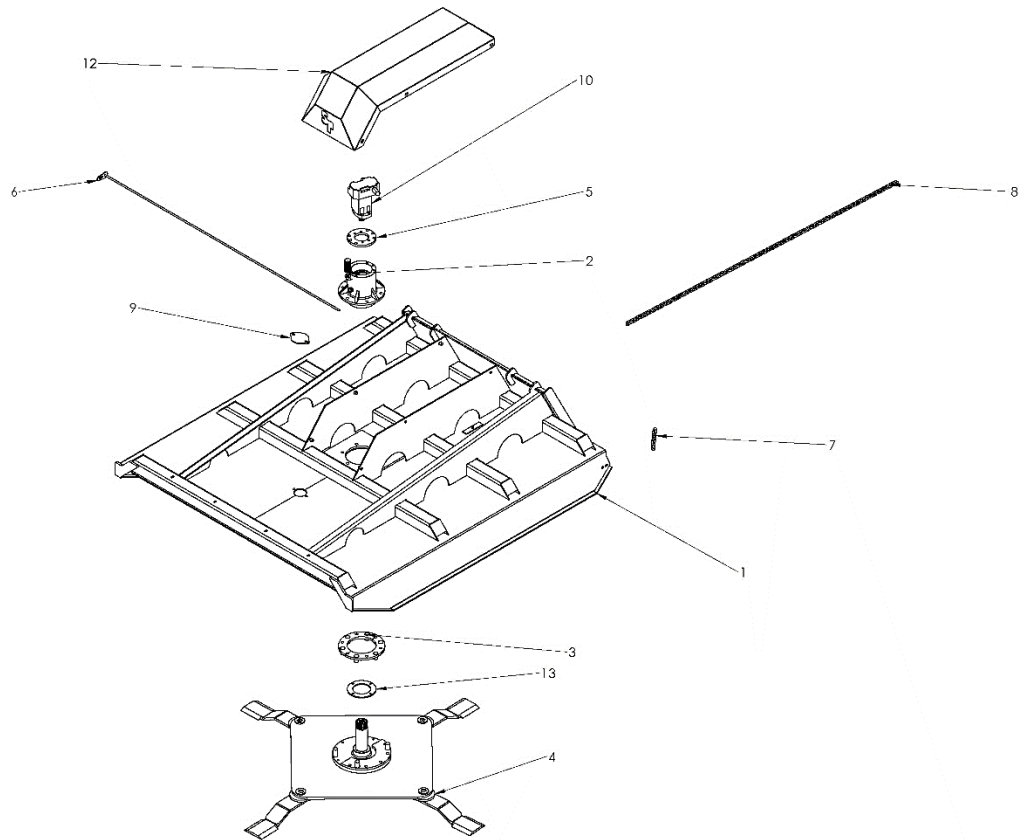

Brush Cutter - Parts List A

ITEM NO.	PART NUMBER	DESCRIPTION	QTY.
1	612-2-0006	Mower Body	1
2	612-2-0005	Bearing Housing	1
3	612-2-0008	Upper Wire protector	2
4	612-2-0012	Flywheel Assembly	1
5	612-3-0026	Motor Mount Plate	1
6	612-2-0011	Chain Rod	1
7	612-3-0045	Chain, Guard	46
8	612-3-0046	Safety Chain	1
9	612-3-0025	Blade Bolt Access Cover	1
10	612-3-0060	Motor	1
12	612-3-0027	Motor Cover	1
13	612-3-0063	Seal Protector	1
14	612-2-0013	3/4" Hose W/Fittings	2
15	612-3-0067	Hose Sleeve	1
16	612-3-0068	Hose clamp	2
17	612-3-0069	Hose Clamp Plate	1
18	612-3-0070	Female Quick Coupler	1
19	612-3-0071	Male Quick Coupler	1

Bearing Housing Assembly - Diagram B

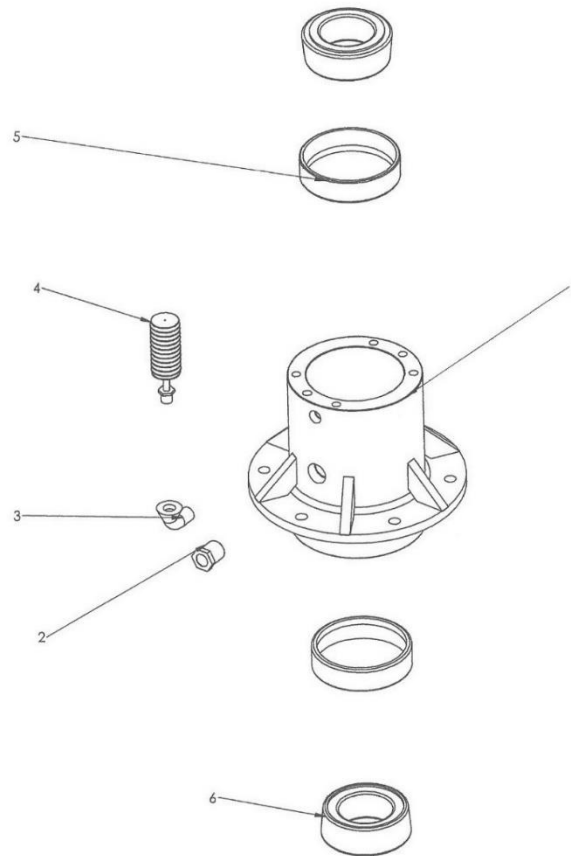

Bearing Housing Assembly – Parts List B

ITEM NO.	PART NUMBER	DESCRIPTION	QTY.
1	612-2-0009	Bearing Housing	1
2	612-3-0055	Sight glass	1
3	612-3-0057	Elbow	1
4	612-3-0056	Expansion Bellows	1
5	612-3-0053	Bearing Race	2
6	612-3-0054	Bearing	2

Bearing Housing Assembly - Diagram B2

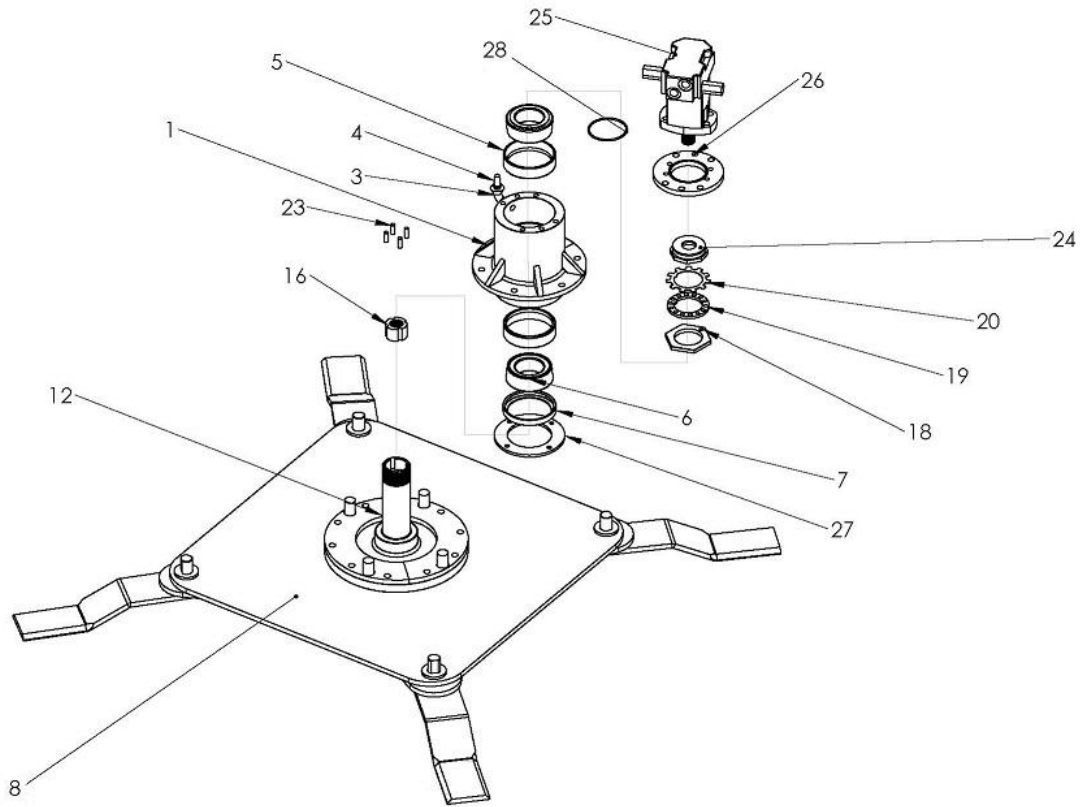

Bearing Housing Assembly - Parts List B2

ITEM NO.	PART NUMBER	DESCRIPTION	QTY.
1	612-2-0009	Bearing Housing	1
3	612-3-0057	3/8 NPT ST 90 Fitting	1
4	612-3-0056	3/8 NPT Breather Plug	1
5	612-3-0053	Bearing Race	2
6	612-3-0054	2 5/8 Tapered Roller Bearing	2
7	612-3-0058	Shaft Seal	1
8	612-2-0004	Flywheel	1
12	612-2-0010	Fly Wheel Shaft	1
16	612-3-0059	Splined Hub	1
18	612-3-0096	2 5/8 Axle Lock Nut	1
19	612-3-0050	Lock Nut Retainer plate	1
20	612-3-0051	Jam Nut retainer	1
21	612-3-0095	2 5/8 Jam Nut	1
22	612-3-0108	3/8 Spacer	1
23	612-3-0097	3/8 X 1 1/4 Dowel Pin	4
24	612-2-0021	Retaining Nut	1
25	612-3-0060	Motor	1
26	612-3-0026	Motor Mounting Plate	1
27	612-3-0063	Seal Protector Plate	1
28	612-3-0132	O-ring (Standard Flow Motor)	1

Motor to Mount Plate and Bearing Housing Hardware Part Numbers

Part Number	Description	QTY.
HDW-1/2INTLW	1/2" Internal Lock Washers	10
HDW-1/2-20X11/4 Ferry Cap Screw	1/2-20 x 1.250 Ferry Head Cap Screws to Mount Motor to Plate	4
HDW-1/2-13x1 1/4	1/2-13 x 1.250 Socket Head Cap Screws to Mount Plate to Bearing Housing	6
HDW-1/2-13x21/2 Hex Flange Bolt	1/2-13 x 2 3/4 Hex Head Bolts to mount Bearing Housing to Mower	6
HDW-1/2-13GRC Flange Lock Nut	1/2-13 GRC Flange Lock Nut Zinc, for Bearing Housing Bolts	6

Torque 1/2"-13 Socket Head Cap Screws to 125 ft. lbs.

Torque 1/2"-13 Hex Head GRD 8 Bolts to 105 ft. lbs.

Torque 1/2"-13 Hex Head GRD 5 Bolts to 80 ft. lbs.

1/2-20 x 1.250 Ferry Head Cap Screws to 150 ft. lbs.

Flywheel Assembly – Diagram C

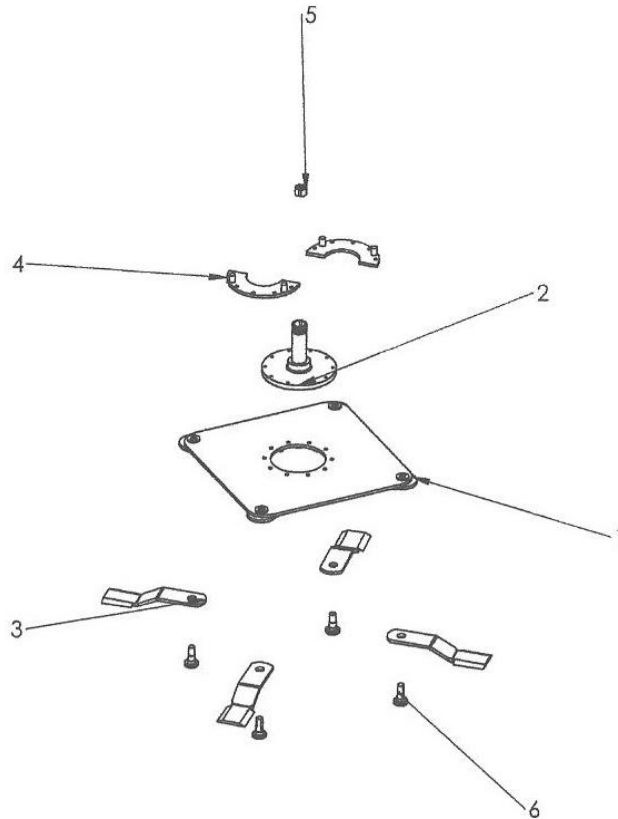

Flywheel Assembly - Parts List C

ITEM NO.	PART NUMBER	DESCRIPTION	QTY.
1	612-2-0004	Flywheel Plate	1
2	612-2-0010	Drive Shaft	1
3	612-3-0013	Blade	4
4	612-2-0007	Wire Protection, Lower	2
5	612-3-0059	Hub	1
6	612-3-0048	Blade Bolt	4

Warning Decal Placement – Diagram D

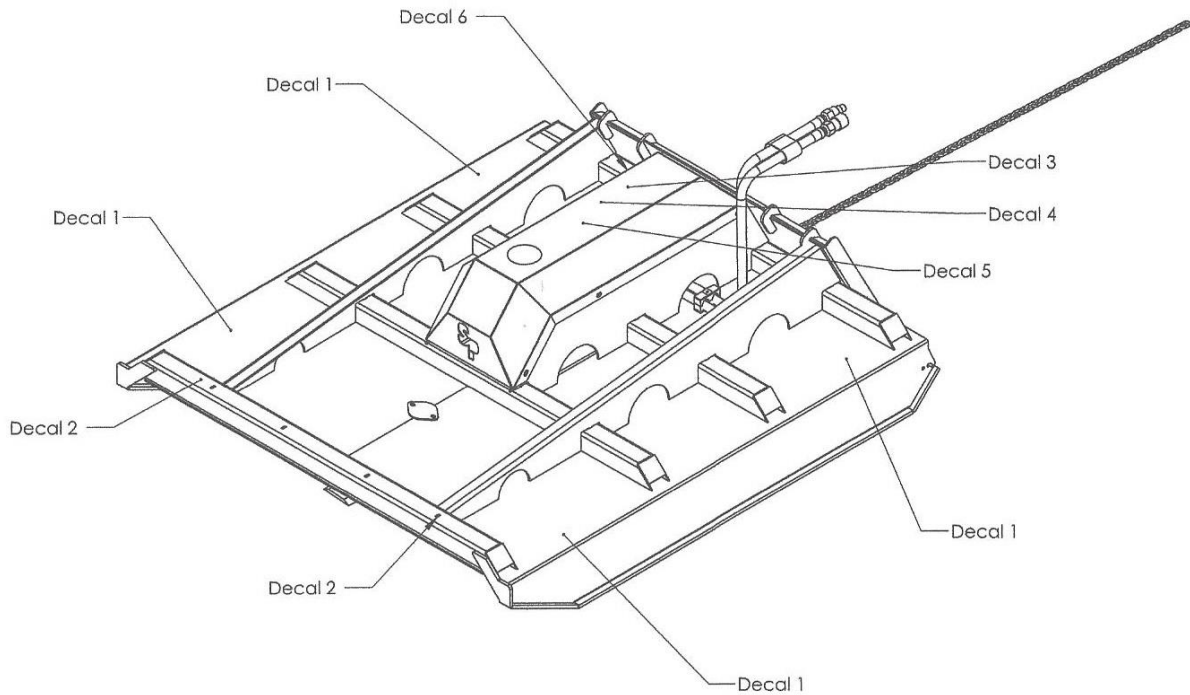

Figure 1 - Brush Cutter - Rear View

Warning Decals - Parts List D

ITEM #	PART NAME	DESCRIPTION	QTY.
1	Warning Decal	Warning Keep Hands and Feet Away	4
2	Warning Decal	DANGER Debris Discharge Area Stay Back 200 Feet	2
3	Warning Decal	Do Not Operate Without Safety Chain In Place	1
4	Warning Decal	High Pressure Fluid Hazard	1
5	Warning Decal	Read Owner's Manual Before Operating	1
6	Identification Decal	Model #/Serial #	1

Warning Decal Graphics

Warning Decal 1



Warning Decal 2



Warning Decal 3



Warning Decal 4



Warning Decal 5

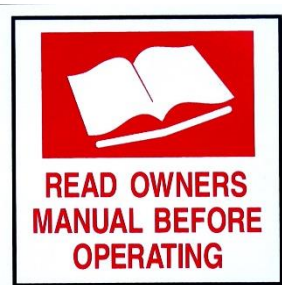

Identification Decal 6

