



**HD3 Open Front  
(standard flow 16-25 gpm)**

**Operation and Maintenance Manual**

Revision Date: September 2021

# Skid Pro Attachments

PO Box 982  
Alexandria, MN 56308  
Toll Free: 877-378-4642  
www.skidpro.com

## Contents

<b>ABOUT THIS OWNER'S MANUAL .....</b>	<b>2</b>
Hazard Notices .....	2
Terminology.....	2
<b>SAFETY.....</b>	<b>2</b>
Safety Notices.....	2
Modifications to Equipment.....	2
<b>ABOUT THE BRUSH CUTTER ATTACHMENT.....</b>	<b>3</b>
Attaching the Brush Cutter to the Carrier Machine.....	3
Removing the Brush Cutter from the Carrier Machine.....	3
<b>BRUSH CUTTER OPERATION .....</b>	<b>4</b>
<b>EQUIPMENT INSPECTION SCHEDULE .....</b>	<b>5</b>
Daily Inspection .....	5
Weekly Inspection .....	5
Monthly Inspection.....	5
Inspection Checklist.....	6
Safety Chain Placement.....	6
<b>PARTS DIAGRAMS AND LISTS.....</b>	<b>7</b>
Brush Cutter - Diagram A.....	7
Brush Cutter – Parts List A .....	8
Drive Assembly - Diagram B .....	9
Drive Assembly - Parts List B.....	10
Flywheel Assembly - Diagram C.....	11
Flywheel Assembly - Parts List C .....	11
Warning Decal Placement – Diagram D.....	12
Warning Decals - Parts List D .....	12
Warning Decal Graphics .....	12
<b>TORQUE SPECIFICATION TABLE.....</b>	<b>13</b>
General Specification Table .....	13
<b>SKID PRO ATTACHMENT WARRANTY .....</b>	<b>14</b>

## ABOUT THIS OWNER'S MANUAL

This manual contains information about the usage and maintenance required for the equipment. This document must be available for review by the operator before using the attachment to ensure proper safety, maintenance, and usage.

### Hazard Notices

The following hazard notices are used in this document:

**NOTE:** Notes are used to indicate important information. This information may be repeated in other areas of the manual.

**CAUTION:** Cautions are used to indicate a potentially hazardous situation, which, if not avoided, may result in damage to the equipment or other property.

**WARNING:** Warnings are used to indicate a potentially hazardous situation, which, if not avoided, could result in serious injury or death.

**DANGER:** Danger is used to indicate a potentially hazardous situation, which, if not avoided, will result in serious injury or death.

### Terminology

**Carrier Machine:** The brush cutter can be attached to many different pieces of equipment; therefore, the term "carrier machine" will be used. A carrier machine is any equipment, tractor, or skid steer providing power to the attachment.

## SAFETY

### Safety Notices

Before operating or conducting maintenance on this equipment, it is important to wear proper protection. Recommended minimum safety equipment when operating and maintaining this equipment includes earplugs, eye protection, and a hard hat. A heavy-duty Lexan door or cab is also recommended.

**NOTE:** Additional safety equipment may be required depending on the operating environment and worksite conditions.

Only qualified and trained personnel should operate, maintain, and service this attachment. Skid Pro recommends that you inspect this equipment regularly for leaks, cracks, or other conditions that may impair proper usage of the equipment. Verify that all repairs have been completed and inspected prior to using the attachment under load.

It is the responsibility of the user to follow all local, state, and federal safety regulations. Improper use of this equipment may result in personal injury, property damage, and/or damage to the equipment.

**NOTE:** Fasten the lift limiter safety chain to your machine with very little slack. See Safety Chain Placement section.

**DANGER:** **DO NOT RAISE THE BACK OF THE CUTTER MORE THAN 12" OFF THE GROUND WHILE OPERATING THE ATTACHMENT. RAISING THE CUTTER DURING OPERATION MAY RESULT IN SERIOUS INJURY OR DEATH.**

### Modifications to Equipment

Any modifications made to this equipment may void any warranty and relieve the manufacturer of liability of any resulting injury or damage.

## ABOUT THE BRUSH CUTTER ATTACHMENT

The brush cutter attachment is intended for use as a brush cutting and clearing tool. The primary use of the brush cutter attachment includes land clearing, landscaping, and grounds maintenance. Use of this equipment in any other manner is contrary to the intended use of the attachment.

### Attaching the Brush Cutter to the Carrier Machine

**NOTE:** Before attempting to attach the brush cutter to the carrier machine, verify that all hydraulic couplings are compatible.

**WARNING:** Improper attachment to the carrier machine may cause personal injury.

**CAUTION:** All hydraulic connections must be clean and free of debris before making any connection.

1. Place the brush cutter attachment on a level surface.
2. Position and align the carrier machine to the rear of the attachment, within proximity of the front of carrier machine.
3. Insert and connect the carrier machine into the attachment.
4. Connect the hydraulic lines from the attachment to the carrier machine.
5. Close latches (or other locking mechanisms) to secure the attachment to the carrier machine.
6. Using the carrier machine, raise the attachment and move the attachment to ensure hydraulic lines are clear of air and operate properly.

**CAUTION:** Hydraulics should operate in an even and smooth manner. Hydraulic movement that is not even and smooth may indicate that air is in the hydraulic lines.

7. Lower the attachment to ground level.
8. Inspect that the attachment is mounted properly and securely. If the attachment does not meet this requirement, follow the instructions to remove the brush cutter and re-attach using the instructions above.

### Removing the Brush Cutter from the Carrier Machine

**WARNING:** Improper disconnection may result personal injury or damage to the attachment and carrier machine.

**CAUTION:** All hydraulic connections must be clean and free of debris before disconnection.

1. Using the carrier machine, lower the attachment to the ground.
2. To prevent contamination, remove any dirt and debris from the couplings. Disconnect the hydraulic connection between the attachment and the carrier machine.



**NOTE:** Hydraulic connections must be disconnected before disengaging latches to prevent damage to the carrier machine or the attachment.

3. Disengage the carrier machine latches (or other locking mechanisms) from the attachment.
4. Move the carrier machine from the attachment.

## BRUSH CUTTER OPERATION

- Operate this attachment with a carrier machine and protective door.
- Wear proper safety equipment as required by working conditions and local, state, and Federal laws.
- Never operate the brush cutter within 200 feet of people, animals, or damageable property. Clear the area of objects that could become projectiles, such as rocks, bottles, and construction debris.
- Never operate the brush cutter with the back more than 12" off the ground or where your view is obstructed.
- Never operate the brush cutter with any guards removed, including the motor cover.
- **Never operate the brush cutter without the safety chain securely fastened to your carrier machine. See Safety Chain Placement section.**
- Disengage the brush cutter and shut off the engine before leaving the cab of your machine.
- Do not place hands or feet near the brush cutter while the machine is running.
- **Standard Flow Brush Cutters are rated for 16-25 GPM with a maximum PSI of 3500.**

**DANGER:** Keep all body parts away from the brush cutter when in use.

	<p><b>Eye and Ear Protection:</b> To help ensure your safety as a designated operator wear eye and ear protection.</p>
	<p><b>Safety Helmet:</b> To help ensure your safety as a designated operator wear a safety helmet.</p>

# EQUIPMENT INSPECTION SCHEDULE

We recommend that you inspect the equipment for damage and wear before every use. Use the following list as a guideline during equipment inspection.

**WARNING:** Do not use hands to check for hydraulic leaks. Keep body parts away from leaking hydraulic lines and couplings that are under pressure.

**NOTE:** Shut off the carrier machine and disengage the bush cutter before performing any maintenance.

## Daily Inspection

Inspect the brush cutter by performing a walk around daily before and after use. Use the following inspection checklist as a guideline.

- After the brush cutter has been attached, check that all latches or locks are closed.
- Check that all hydraulic fittings are tight and free of leaks.
- Check sight glass on direct drive to ensure presence of oil. If needed add 80/90 weight gear oil. If oil is not present or very low check drive train for leaks.
- Check that all hydraulic lines are free of leaks, holes, or cracks. Replace as required.
- Check all hardware connections to the carrier machine for damage or fatigue such as cracks or other structural flaws.
- Inspect the safety chain for damage.
- Inspect blades and bolts for wear or damage
- Inspect all drive train bolts (motor, mount, housing, and blade) for loosening. Tighten as needed.
- Check for wire or debris under the deck, remove any present.
- Clean debris from the motor area.
- Check that all guards and safety equipment are in good condition.

## Weekly Inspection

- Check blade bolts for correct torque (500 foot/pounds).
- Check all bolts for tightness.
- Inspect the deck for cracks, bends, or damage.
- Inspect discharge chains and replace any missing or broken chains.

## Monthly Inspection

- Inspect the entire drive system, including motor, and bearing housing.
- Inspect the blades for cracks, bends, or excessive wear.
- Check skid plates for wear.
- Inspect the bolts on the motor. Tighten if required.
- Check that all bolts are tight.

## Inspection Checklist

- Are all safety notices and warning stickers in proper locations and visible?
- Are all safety guards properly installed and in good condition?
- Are there any visible hydraulic leaks?
- Is there oil visible in sight glass?
- Is there any wire or vines wound under the deck?
- Are any cracks visible in brush cutter structure?
- Are the blades worn, bent, or broken?
- Has all debris been removed from the motor area?
- Has the carrier machine been properly inspected for hydraulic leaks and proper tire inflation?
- Has the carrier machine been properly maintained?

## Safety Chain Placement

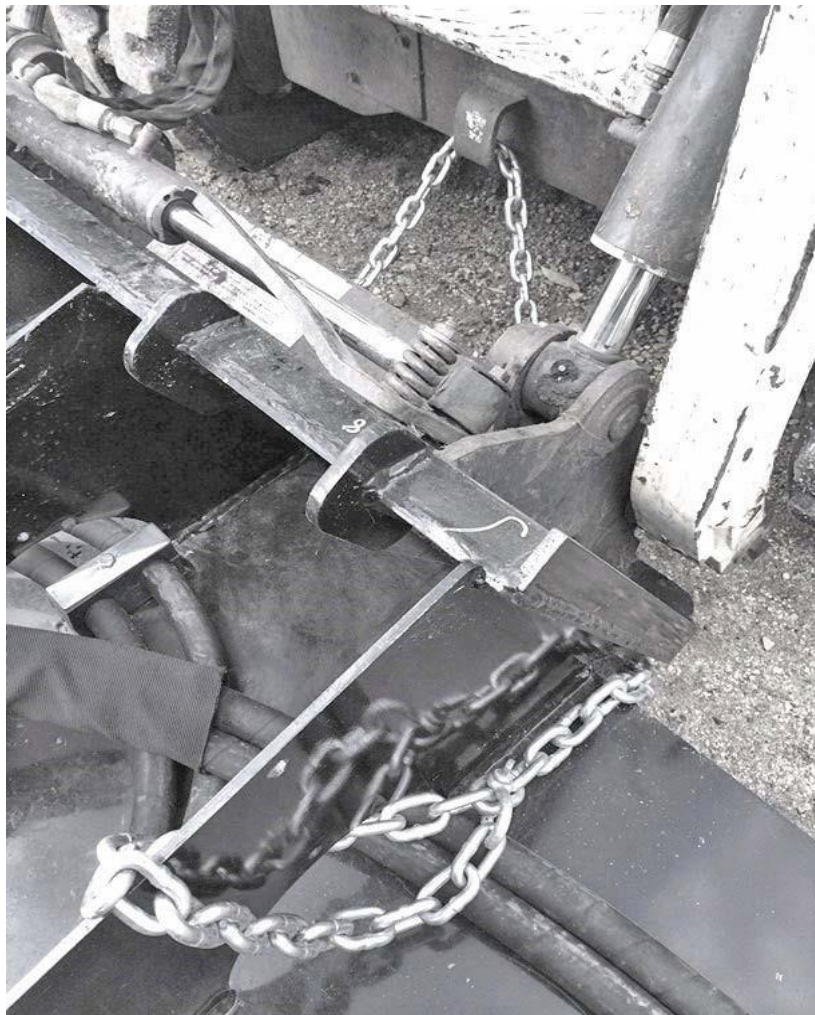

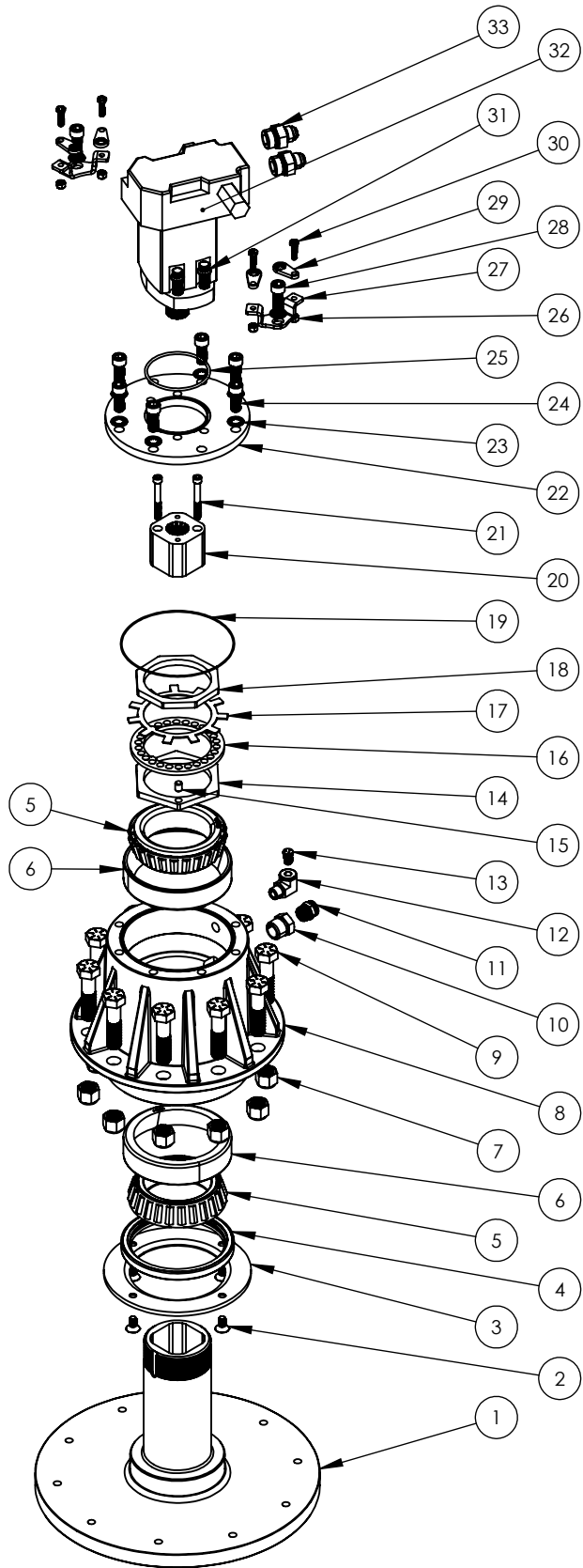



ITEM NO.	PART NUMBER	DESCRIPTION	QTY.
1	612-2-0025	MOWER SPINDLE SHAFT	1
2	HW-.375-16X.75 FS	3/8"-16 X 3/4" FLAT HEAD CAP SCREW	4
3	612-3-0063-2	SEAL PROTECTION	1
4	RTD-52625TA-H	OIL SEAL	1
5	612-3-0054-2	594A TAPERED BEARING	2
6	612-3-0053-2	592 TAPERED BEARING RACE	2
7	HW-.750-16 NYL G8	3/4"-16 NYLOCK NUT	10
8	612-2-0024	BEARING HOUSING	1
9	HW-.750-16X3 G8	3/4"-16 X 3" GRADE 8 BOLT	10
10	H750-5406-12-08	3/4 MNPT X 1/2 FNPT BUSHING	1
11	H500-H1820	HD BUTTON HEAD GREASE FITTING	1
12	H375-5502-06-02	3/8 MNPT X 1/8 FNPT 90 DEG	1
13	H125-A321620	1/8 NPT STRAIGHT BREATHER	1
14	612-3-0096-2	LOCK NUT	1
15	HW-.375X.50 DP	3/8" X 1/2" DOWEL PIN	1
16	612-3-0050-2	LOCK NUT RETAINER	1
17	612-3-0051-2	JAM NUT RETAINER	1
18	612-3-0095-2	JAM NUT	1
19	612-3-0133	ORING (BEARING HOUSING TO MOTOR PLATE)	1
20	612-3-0110-20	HUB, STANDARD FLOW	1
21	HW-.312-24X2.5 CS	5/16"-16 X2 1/2" SOCKET HEAD CAP SCREW	2
22	612-3-0111-20	MOTOR MOUNT PLATE STANDARD FLOW	1
23	HW-.500 INTLW	1/2" INTERNAL LOCK WASHER	8
24	HW-.500-20X1.25CS	1/2"-20 X 1 1/4" SOCKET HEAD CAP SCREW	6
25	612-3-0132	ORING (STANDARD FLOW MOTOR)	1
26	HW-.25-20 NYL	1/4"-20 NYLOCK NUT	4
27	612-3-0213	BOLT RETAINER BRACKET	2
28	HW-.500-20X1.5CS	1/2"-20 X 1-1/2" SOCKET HEAD CAP SCREW	2
29	612-3-0210	BOLT RETAINER TAB	4
30	HW-.25-20X1.0G5	1/4"-20X1" GRADE 5 BOLT	4
31	HW-.50-20X1.25FCS	1/2"-20 X 1-1/4" FERRY CAP SCREW	4
32	612-3-0060	MOTOR, STANDARD FLOW	1
33	H750-FT21-10-12	10 MALE ORB TO 12 FEMALE JIC	2

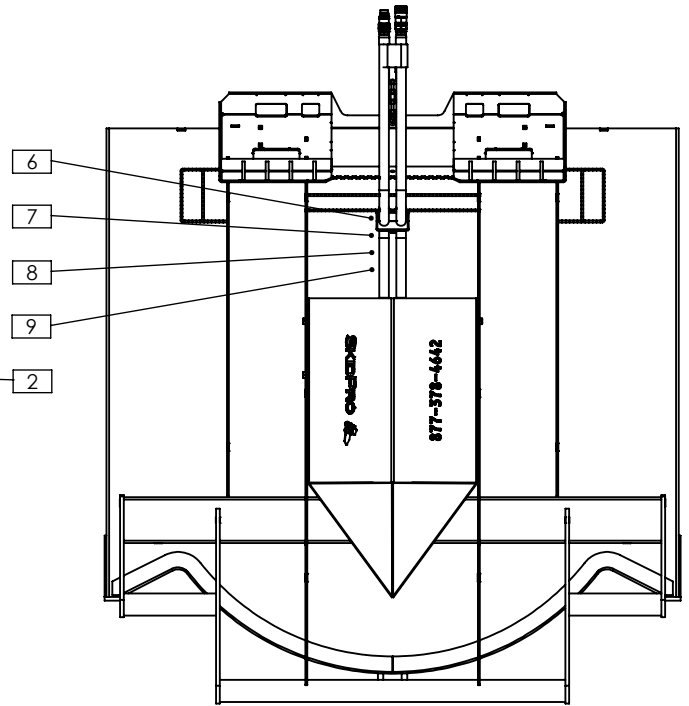
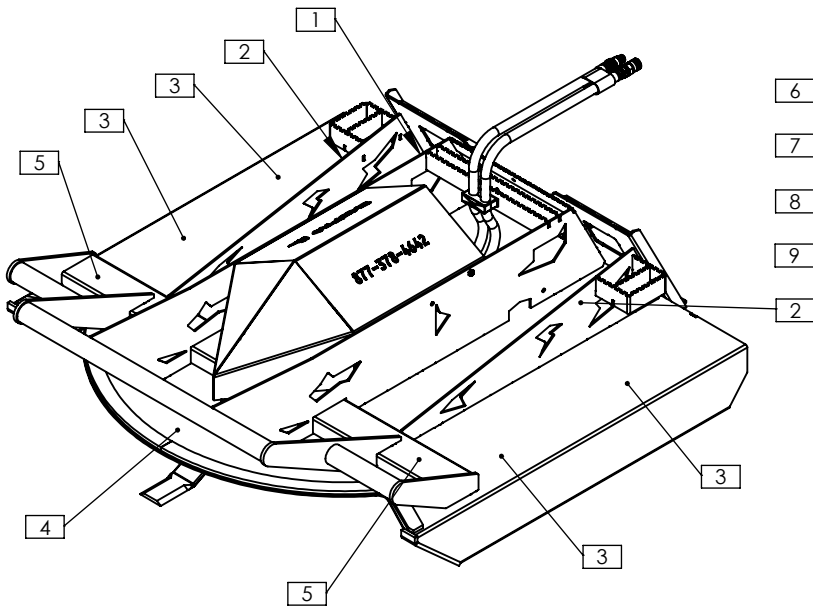

ITEM NO.	PART NUMBER	DESCRIPTION	QTY.
1	DECAL-3-XXXX	765-1-XXXX SERIAL DECAL	1
2	DECAL-3-0003	4X5 "72" ORANGE & BLACK	2
*2	DECAL-3-0142	4X5 "60" ORANGE & BLACK	2
3	DECAL-3-0004	3X10 "WARNING"	4
4	DECAL-3-0005	2.5X10 "SKID PRO" CLEAR BACK	1
5	DECAL-3-0006	2.25X10 "DANGER"	2
6	DECAL-3-0008	3X5 "HIGH PRESSURE FLUID"	1
7	DECAL-3-0009	3X3 "READ OWNERS MANUAL"	1
8	DECAL-3-0010	5X5 "DO NOT OPERATE WITHOUT SA"	1
9	DECAL-3-0011	4X6 "CAUTION 25 GPM MAX"	1
*DENOTES DECALS FOR 60" MODEL			

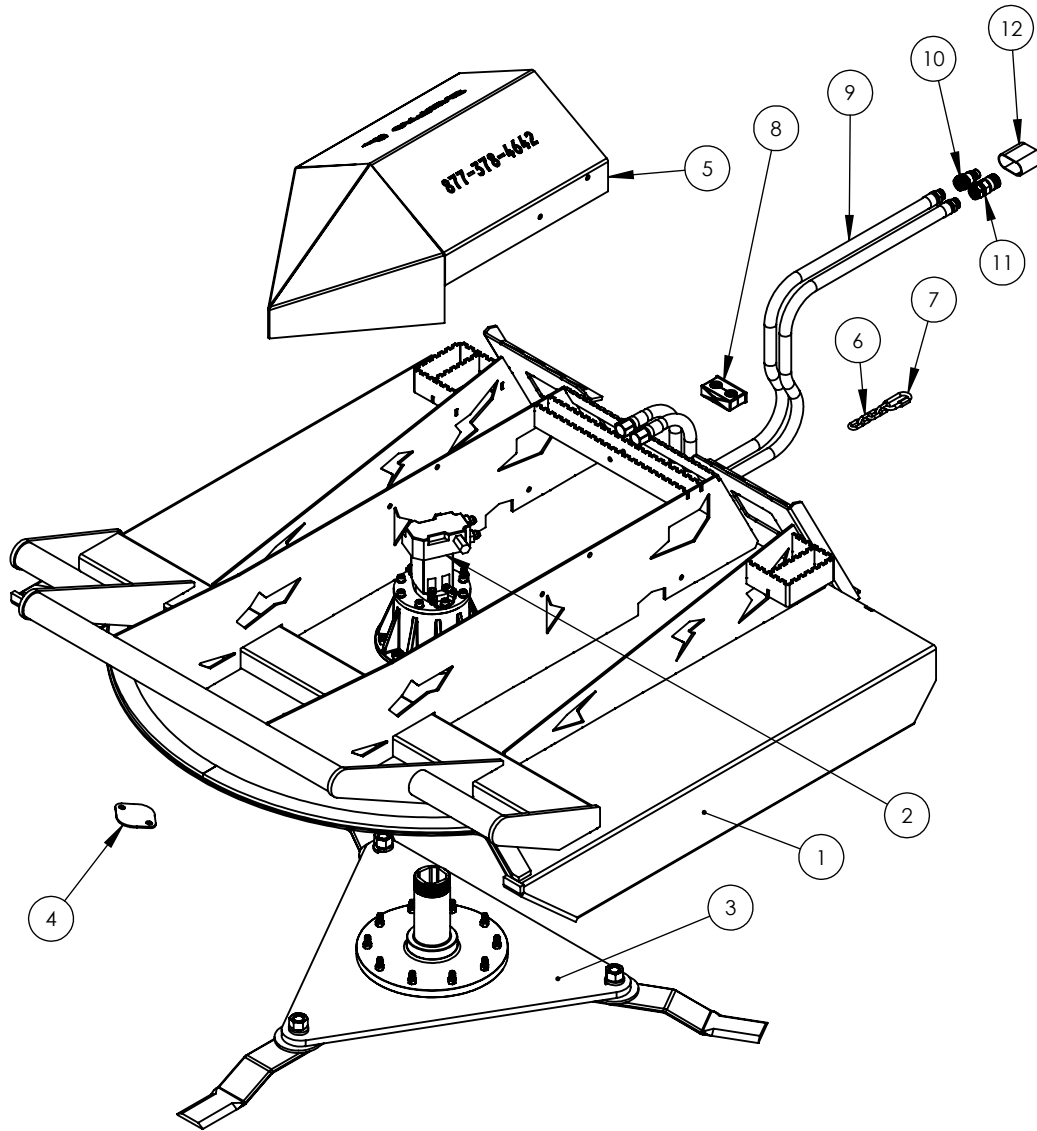

ITEM NO.	PART NUMBER	DESCRIPTION	QTY.
1	765-02-0001-72	72" 3 BLADE BODY	1
*1	765-02-0001-60	60" 3 BLADE BODY (NOT PICTURED)	1
2	DRIVE ASSEMBLY	STANDARD FLOW	1
3	765-02-0017-72	FLYWHEEL ASSEMBLY - 72"	1
*3	765-02-0017-60	FLYWHEEL ASSEMBLY - 60"	1
4	612-3-0025	INSPECTION COVER	1, 2
5	612-2-0035	COVER	1
6	612-3-0046	SAFETY CHAIN	1
7	612-3-0128	3/8 QUICK LINK	1
8	H750-HOSE CLAMP	TWIN HOSE CLAMP 3/4" HOSE	1
9	612-2-0013	3/4" X 108" HOSE	2
10	AU-03-9991-12-12	1/2" MALE FLAT FACE COUPLER	1
11	AU-03-9990-12-12	1/2" FEMALE FLAT FACE COUPLER	1
12	HSL750	HOSE SLEEVE	5 FT

\*DENOTES ALTERNATE OPTION

## 72" FLYWHEEL ASSEMBLY

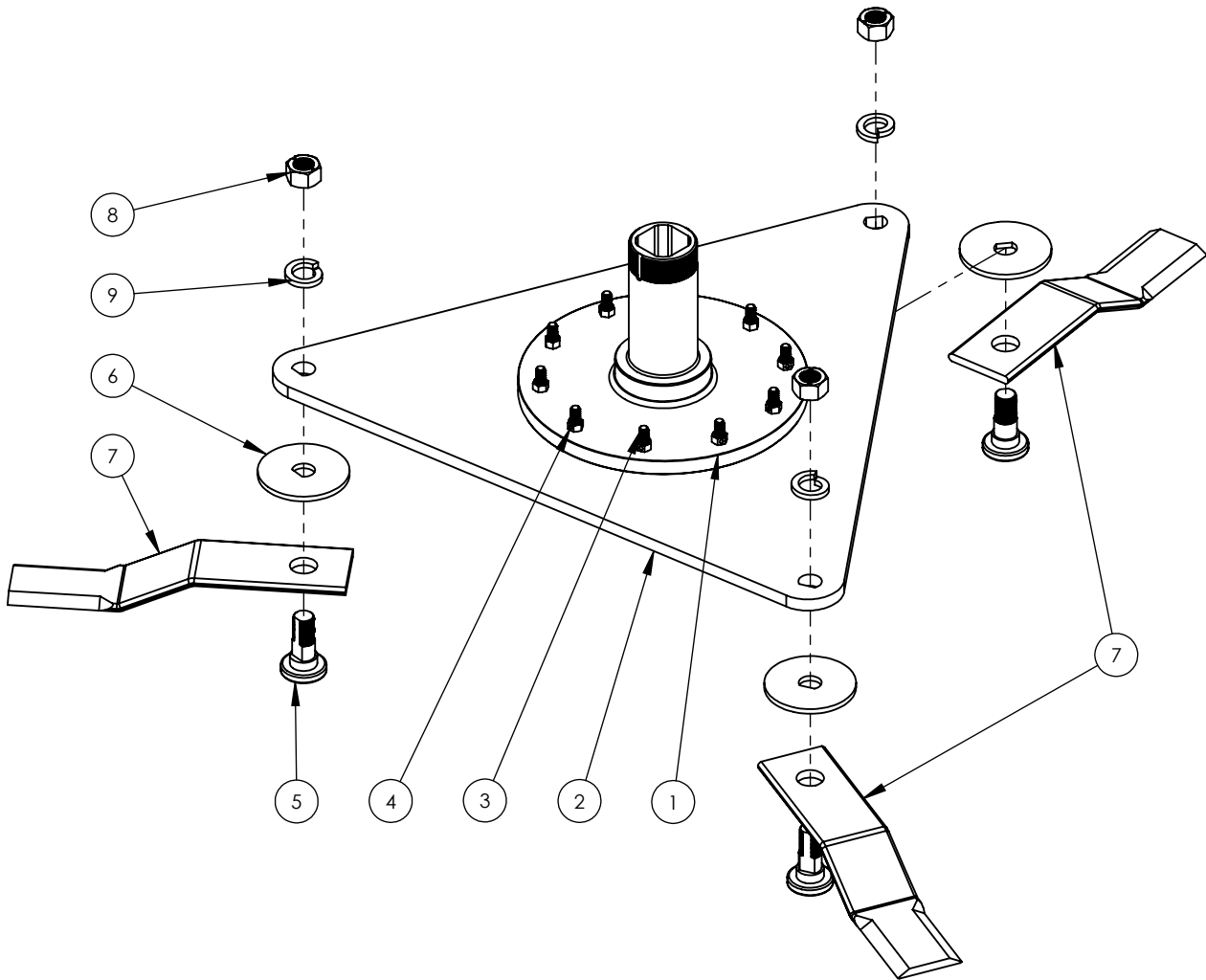

- EACH BLADE GETS (1X) SPACER
- ASSEMBLE WITH **RED LOCTITE**

ITEM NO.	PART NUMBER	DESCRIPTION	QTY.
1	612-2-0025	MOWER SPINDLE SHAFT	1
2	765-03-0017-72	3 BLADE FLYWHEEL - 72"	1
3	HW-.500-13X3 G8	1/2"-13 X 3" G8	10
4	HW-.500-13 RLN	1/2"-13 REVERSE LOCK NUT	10
5	612-3-0048	BLADE BOLT	3
6	612-3-0049	BLADE BOLT SPACER	3
7	612-3-0013	BLADE	3
8	HW-1.125-12 TLHN	1 1/8" -12 INTERNAL LOCKING NUT	3
9	HW-1.25 LW	1 1/4" LOCK WASHER	3

## 60" FLYWHEEL ASSEMBLY

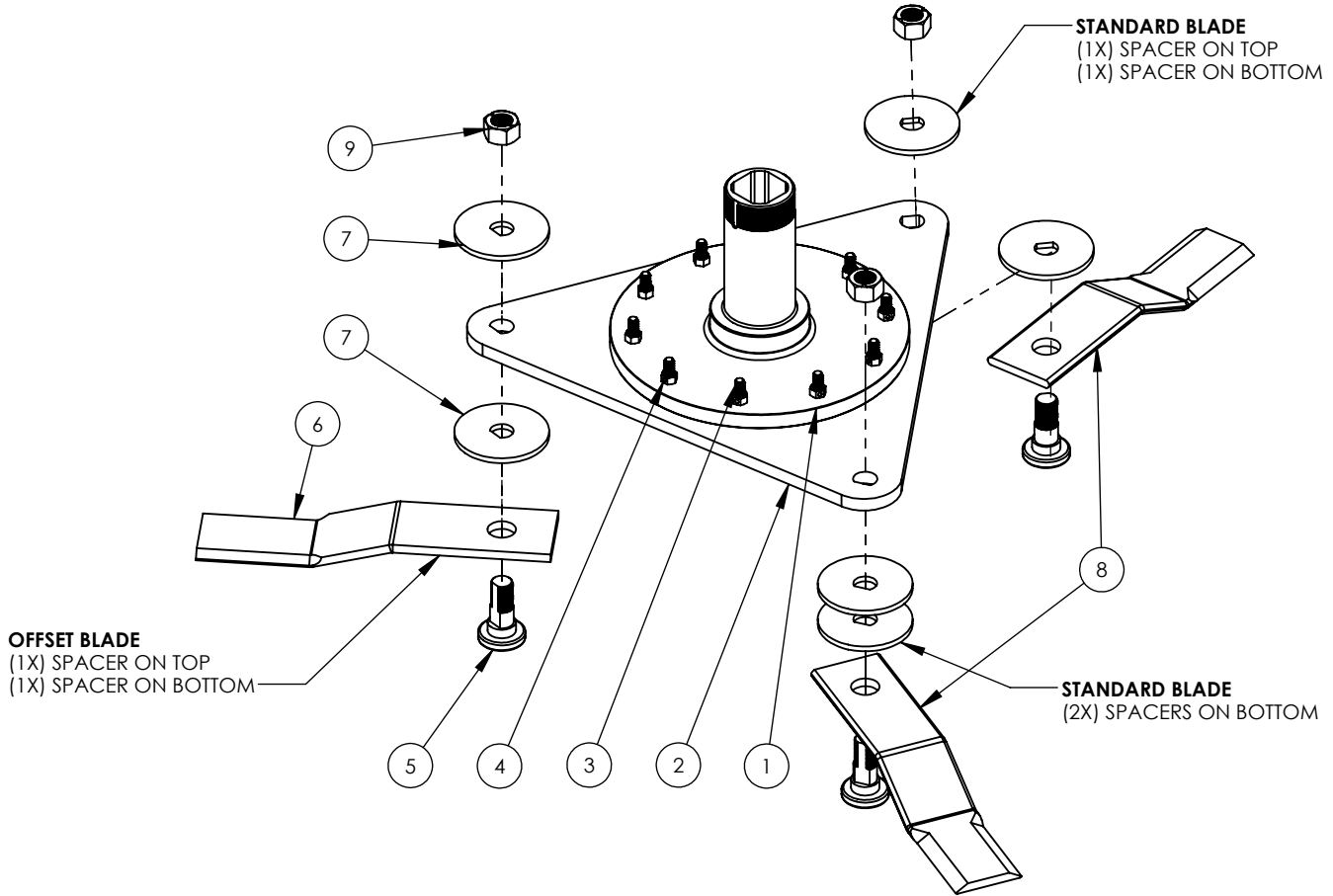

- EACH BLADE GETS (2X) SPACERS
- ASSEMBLE WITH **RED LOCTITE**
- DO NOT USE LOCKWASHER ON TOP

ITEM NO.	PART NUMBER	DESCRIPTION	QTY.
1	612-2-0025	MOWER SPINDLE SHAFT	1
2	765-03-0017-60	3 BLADE FLYWHEEL - 60"	1
3	HW-.500-13X3 G8	1/2"-13 X 3" G8	10
4	HW-.500-13 RLN	1/2"-13 REVERSE LOCK NUT	10
5	612-3-0048	BLADE BOLT	3
6	612-3-0013-OS	OFFSET BLADE	1
7	612-3-0049	BLADE BOLT SPACER	6
8	612-3-0013	BLADE	2
9	HW-1.125-12 TLHN	1 1/8" -12 INTERNAL LOCKING NUT	3

# TORQUE SPECIFICATION TABLE

## General Specification Table

Use the following torques when special torques are not given. Note: These values apply to fasteners as received from supplier, when dry. These values do not apply if lubricants are used.

<b>BOLT SIZES (SAE)</b>	<b>TORQUE</b>	
<b>INCHES</b>	<b>POUNDS-FOOT (NC Threads) Grade 5 / Grade 8</b>	<b>POUNDS-FOOT (NF Threads) Grade 5 / Grade 8</b>
1/4	7/11	9/13
5/16	15/22	17/24
3/8	30/40	35/45
7/16	45/65	50/70
1/2	70/95	75/110
9/16	100/140	110/155
5/8	135/190	155/215
3/4	240/340	270/380
7/8	360/550	390/610
1	530/820	590/890
1 1/8	800/1440	880/1500
1 1/4	1240/2000	1364/2200
1 3/8	1680/2720	1848/2800
1 1/2	2200/3500	2420/3600

<b>BOLT SIZES (METRIC)</b>	<b>TORQUE</b>	
<b>MILLIMETERS</b>	<b>POUNDS-FOOT</b>	<b>NEWTONS-METER</b>
M6	10	13
M8	22	30
M10	40	54
M12	59	80
M14	93	126
M16	130	176
M18	168	228
M20	205	278



PO Box 982, 807 McKay Ave S.  
Alexandria, MN 56308  
Toll Free: 877-378-4642  
[www.skidpro.com](http://www.skidpro.com)

## SKID PRO WARRANTY

Skid Pro warrants above attachments for twenty-four months from date of shipment to the original owner. Warranty covers products to be free from defects in material and workmanship when properly set up and operated in accordance with Skid Pro's recommendations.

### WARRANTY CLAIM PROCEDURE

All warranty claims must be submitted within the manufacturer's limited warranty period. Pictures and/or a video as well as a detailed description of the events leading up to the failed component(s) are required to properly document all potential warranty claims. To submit a warranty claim, contact your Skid Pro Product Guru or complete a [Warranty Claim Form](#) on our website and send it along with supporting pictures/video to [sales@skidpro.com](mailto:sales@skidpro.com). A valid credit card is required to be on file with Skid Pro to begin processing a warranty claim. No warranty claim will be processed without a valid credit card on file. Upon receipt, the warranty claim information will be reviewed and once determined to be a valid claim, a return authorization number will be issued for the return of the defective part(s) if applicable and replacement part(s) will be shipped. If it is determined the defective parts are to be returned and they are not received by Skid Pro within 30 days of receiving the replacement parts, the buyer's credit card on file will be charged for the cost of the replacement parts plus any shipping charges. Tampering with the failed part (i.e. disassembling a motor or cylinder) will void the warranty.

### EXCLUSIONS OF WARRANTY

Skid Pro's requirement for any issue with respect to attachments shall be limited to repairing or replacing the defective part, as this is a parts-only warranty and does not include labor to replace or install the part, interest accrued or payments made for financing, or downtime from resulting issue. Skid Pro has full technical support to assure customer replaces the part properly.

This warranty shall not apply to any attachment's wear items, or attachments that have been repaired or altered outside the Skid Pro factory in any way, or that has been subject to misuse, negligence, or accident beyond Skid Pro's recommended use and/or machine rated capacity.

This warranty is exclusive and in lieu of all other warranties and conditions. Skid Pro disclaims all other warranties and conditions, express or implied, including any implied warranties or conditions of merchantability or fitness for a particular purpose. In no event shall Skid Pro be liable for any special, incidental, indirect or consequential damage, whatsoever, including, but not limited to, loss or interruption of business, lost profits, or loss of machine use, whether based on contract, warranty, tort, negligence, strict liability, statute or otherwise, even if Skid Pro has been advised of the possibility of such damages.

Hoses and couplers are tested on the attachment prior to shipment and are excluded from the warranty. It is the responsibility of the operator to ensure adequate clearance and hose routing as each carrier machine differs and improper routing can lead to hose damage and premature failure. If hose length is an issue due to the style or type of carrier machine, it is the responsibility of the end user to source correctly sized hoses as they are outside of the normal distribution of carrier machines within the industry.

No agent, employee, or representative of Skid Pro has any authority to bind said company to any affirmation, representation, or warranty concerning its machinery and/or attachments except as specifically set forth herein. Any disagreement or dispute of warranty policy or customer expectations of product, soundness, functionality, or performance would take place in Douglas County, Alexandria, MN, where Skid Pro operates.



**PO BOX 982  
Alexandria, MN 56308**

**Phone: 877-378-4642  
FAX: 320-759-1057  
[www.skidpro.com](http://www.skidpro.com)  
[sales@skidpro.com](mailto:sales@skidpro.com)**