



Grapple Rake

Operation and Maintenance Manual



Revision Date: Jan 2024

Skid Pro Attachments

PO Box 982

Alexandria, MN 56308

Toll Free: 877-378-4642

www.skidpro.com

Contents

ABOUT THIS MANUAL	2
Hazard Notices Used in this Manual	2
Terminology	2
SAFETY	2
Safety Notices	2
Modifications to Equipment	2
ABOUT THE GRAPPLE RAKE ATTACHMENT	3
Attaching the Grapple Rake to the Carrier Machine	3
Removing the Grapple Rake from the Carrier Machine	3
Transporting	4
Storage	4
OPERATION AND MAINTENANCE	5
Equipment Inspection.....	5
Usage Guidelines.....	5
Inspection Checklist	5
MAINTENANCE	6
GRAPPLE RAKE PARTS DIAGRAM	7
GRAPPLE RAKE PARTS LIST	8
TORQUE SPECIFICATION TABLE	9
General Specification Table	9
SKID PRO ATTACHMENT WARRANTY	10

ABOUT THIS MANUAL

This manual contains information about the usage and maintenance required for the equipment. This document must be available for review by the operator before using the attachment to ensure proper safety, maintenance, and usage.

Hazard Notices Used in this Manual

The following hazard notices are used in this document:

NOTE – Notes are used to indicate important information. This information may be repeated in other areas of the manual.

CAUTION – Cautions are used to indicate a potentially hazardous situation which, if not avoided, may result in damage to the equipment or other property.

WARNING – Warnings are used to indicate a potentially hazardous situation which, if not avoided, could result in serious injury or death.

DANGER – Danger is used to indicate a potentially hazardous situation which, if not avoided, will result in serious injury or death.

Terminology

Carrier machine: The grapple rake can be attached to many different pieces of equipment; therefore, the term “carrier machine” will be used. A carrier machine is any equipment, tractor, or skid steer providing power to the attachment.

SAFETY

Safety Notices

Before operating or conducting maintenance on this equipment, it is important to wear proper protection. Recommended safety equipment when operating and maintaining this equipment includes earplugs, eye protection, and a hard hat.

NOTE: Additional safety equipment may be required depending on the operating environment and worksite conditions.

Only qualified and trained personnel should operate, maintain, and service this attachment. It is recommended that this equipment be inspected regularly for leaks, cracks, or other conditions that may impair proper usage of the equipment. Verify that all repairs have been completed and inspected prior to using the attachment under load.

It is the responsibility of the user to follow all local, state, and federal safety regulations. Improper use of this equipment may result in personal injury, property damage, and/or damage to the equipment.

Modifications to Equipment

Any modifications made to this equipment may void any warranty and relieve the manufacturer of liability of any resulting injury or damage.

ABOUT THE GRAPPLE RAKE ATTACHMENT

The grapple rake attachment is intended for use in materials handling. The primary use of the grapple rake attachment includes land clearing, landscaping, demolition, construction, and grounds maintenance. Use of this equipment in any other manner is considered to be contrary to the intended use of the attachment.

Attaching the Grapple Rake to the Carrier Machine

NOTE: Before attempting to attach the grapple rake to the carrier machine, verify that all hydraulic couplings are compatible.

WARNING – Improper attachment to the carrier machine may cause personal injury.

CAUTION – All hydraulic connections must be clean and free of debris before making any connection.

1. Place the grapple rake attachment on a level surface.
2. Position and align the carrier machine to the rear of the attachment, within proximity of the front of carrier machine.
3. Insert and connect the carrier machine into the attachment.
4. Connect the hydraulic lines from the attachment to the carrier machine.
5. Close latches (or other locking mechanism) to secure the attachment to the carrier machine.
6. Using the carrier machine, raise the attachment and move the attachment to ensure hydraulic lines are clear of air and operate properly.

CAUTION – Hydraulics should operate in an even and smooth manner. Hydraulic movement that is not even and smooth may indicate that air is in the hydraulic lines.

7. Lower the attachment to ground level.
8. Inspect that the attachment is mounted properly and securely. If the attachment does not meet this requirement, follow the instructions to remove the Industrial grapple rake and re-attach using the instructions above.

Removing the Grapple Rake from the Carrier Machine

WARNING – Improper disconnection may result person injury or damage to the attachment and carrier machine.

CAUTION – All hydraulic connections must be clean and free of debris before disconnection.

1. Using the carrier machine, lower the attachment to the ground.
2. To prevent contamination, remove any dirt and debris from the couplings. Disconnect the hydraulic connection between the attachment and the carrier machine.

NOTE: Hydraulic connections must be disconnected before disengaging latches to prevent damage to the carrier machine or the attachment.

3. Disengage the carrier machine latches (or other locking mechanisms) from the attachment.
4. Move the carrier machine from the attachment.

Transporting

1. Transporting on public roadway: When driving the skid steer and equipment on the road or highway under 25 mph, at night or during the day, use flashing amber warning lights and the Slow Moving Vehicle ("SMV") identification emblem.
2. Check local traffic codes that may apply to unit usage on public roads and highways in your area. The use of flashing amber lights is acceptable in most localities. However, some localities may prohibit their use.
3. Always disengage equipment drive prior to transporting unit.

Storage

Before storing the dozer blade, certain precautions should be taken to protect it from deterioration.

1. Clean the grapple rake throughout.
2. Make all the necessary repairs.
3. Replace all safety signs that are damaged, lost, or otherwise become illegible. If a part to be replaced has a sign on it, obtain a new safety sign from your dealer and install it in the same place as on the removed part.
4. Repaint all parts from which paint has worn or peeled.
5. When the grapple rake is dry, oil all moving parts. Apply oil liberally to all surfaces to protect against rust.
6. Store in a dry place

OPERATION AND MAINTENANCE

Equipment Inspection

It is recommended that you inspect the grapple rake daily before use. It is also recommended that the grapple rake be inspected after extreme use or damage. Use the inspection checklist below as a guideline. Use the following list as a guideline during equipment inspection.

Usage Guidelines

Use the grapple rake for materials handling only.

DANGER – Keep all body parts away from the grapple rake when in use. The upper tines may open or close unexpectedly causing serious bodily injury or death.

Inspection Checklist

- Are all safety notices and warning decals in proper locations and visible?
- Are all latches or locks are closed?
- Are all hardware connections to the carrier machine free of damage or fatigue such as cracks or other structural flaws?
- Are all hydraulic fittings are tight and free of leaks?
- Are all hydraulic lines are free of leaks, holes, or cracks?
WARNING – Do not use hands to check for hydraulic leaks. Keep body parts away from leaking hydraulic lines and couplings that are under pressure.
- Are any cracks visible in grapple rake structure?
- Are the tines worn or bent?
- Have all grease fittings (zerk fittings) have been greased?
- Are the bolts holding pins secure and tight?
- Has the carrier machine been properly inspected for hydraulic leaks and proper tire inflation?
- Has the carrier machine been properly maintained?
- Are the tires on the carrier machine are in good condition and have proper load ratings?

NOTE: Replace any damaged hardware, hoses, and fittings before using the equipment.

MAINTENANCE

Always use genuine parts when replacement parts are required during operation.

1. Keep the skid steer and grapple rake properly maintained.
2. Park the skid steer/grapple rake on level ground, place the transmission in neutral, set the parking brake, disengage the Aux hydraulics, lower the equipment to the ground, place all control levers in neutral, shut off the engine and remove the ignition key and allow the rotating parts to stop BEFORE making any grapple rake adjustments.
3. To avoid injury, do not adjust or service the grapple rake with the skid steer engine running. Make sure moving components have completely stopped before leaving the operator's seat.
4. Keep the skid steer/grapple rake clean.
5. Always wear eye protection when cleaning or servicing the grapple rake.
6. Service the unit in safety: DO NOT service the skid steer while the engine is running or hot, or if the unit is in motion. Always lower grapple rake to the ground. If necessary to service unit with grapple rake raised, securely support with stands or suitable blocking before working underneath. Do not rely on hydraulically supported devices for your safety. They can settle suddenly, leak down, or be accidentally lowered.
7. Do not attempt to service machine, clear obstructions or unplug blockages with the engine running. Always shut off engine and allow all motion to cease.
8. The manufacturer will not claim responsibility for fitment of unapproved parts and/or accessories and any damages as a result of their use.
9. Make sure all shields and guards are securely in place following all service, cleaning, or repair work.
10. Do not modify or alter this equipment or any of its components or operating functions. If you have any questions concerning modifications, consult with your dealer.
11. Do not operate a unit which is defective or has missing parts. Make sure that all recommended maintenance procedures are completed before operating the unit.
12. Check all controls regularly and adjust where necessary.
13. Periodically check all nuts and bolts for tightness, especially wheel hub and rim nuts. Make sure all non-rotating pins are secured properly.
14. Check hydraulic cylinders and hoses for damage or leaks. To avoid serious personal injury: Escaping hydraulic/diesel fluid under pressure can penetrate the skin causing serious injuries. Do not use your hands to check for leaks. Use a piece of cardboard or paper to search for leaks.
15. Stop engine and relieve pressure before connecting lines. Tighten all connections before starting engine or pressurizing lines.

ITEM NO.	PART NUMBER	DESCRIPTION	QTY.
1	657-02-0016-XX	IGR BOTTOM	1
2	657-02-0021	IGR TOP L.H.	1
3	657-02-0022	IGR TOP R.H.	1
4	657-02-0010	2.5 X 10 CYLINDER	2
5	SP-2019-4	PLACARD	2
6	657-3-0070	SPACER	6
7	657-3-0077	FILLER PLATE	1
8	657-3-0078	FILLER PLATE	1
9	657-3-0073	CYLINDER PIN	2
10	657-3-0074	OUTER PIVOT PIN	2
11	657-3-0075	INNER PIN	2
12	657-3-0076	CYLINDER PIN	2
13	657-3-0079	1 1/4 SNAP RING	8
14	657-3-0080	1" SNAP RING	8
15	657-02-0024	MACHINE HOSE	2
16	AU-03-PH2509-11	LEFT HOSE	2
17	632-3-25084	RIGHT HOSE	2
18	HSL250	.250" HOSE SLEEVE	1
19	AU-03-9991-8ORB90	90° FEMALE FLAT FACE COUPLER	1
20	AU-03-9990-8ORB90	90° MALE FLAT FACE COUPLER	1
21	H250-FT1108	8 MALE ORING X 1/4 NPT FEMALE	2
22	H250-FT02	1/4" NPT STREET TEE	2
23	H250-FT10	1/4" FEMALE NPT X 1/4" FEMALE NPT SWIVEL	2
24	H250-FT1208	-8 MORB X 1/4 NPT SWIVEL 90° FITTING	4
25	HW-.125-NPTS GF	.125 STRAIGHT GREASE ZERK	5
26	HW-.750-10X4.0 G8	3/4"-10 X 4" GRADE 8 BOLT	3
27	HW-.750-10 NYL G8	3/4-10 NYLOCK NUT ZINC	3
28	HW-.375-16X1.0 G5	3/8"-16 X 1" GRADE 5 BOLT	8
29	HW-.375-16 NYL	3/8 - 16 NYLOCK NUT	12
30	HW-.375-16X4.0G5	3/8"-16 X 4" GRADE 5 BOLT	4

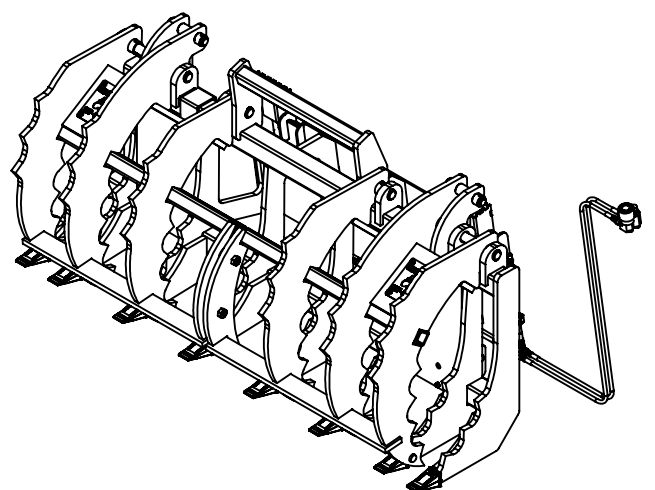
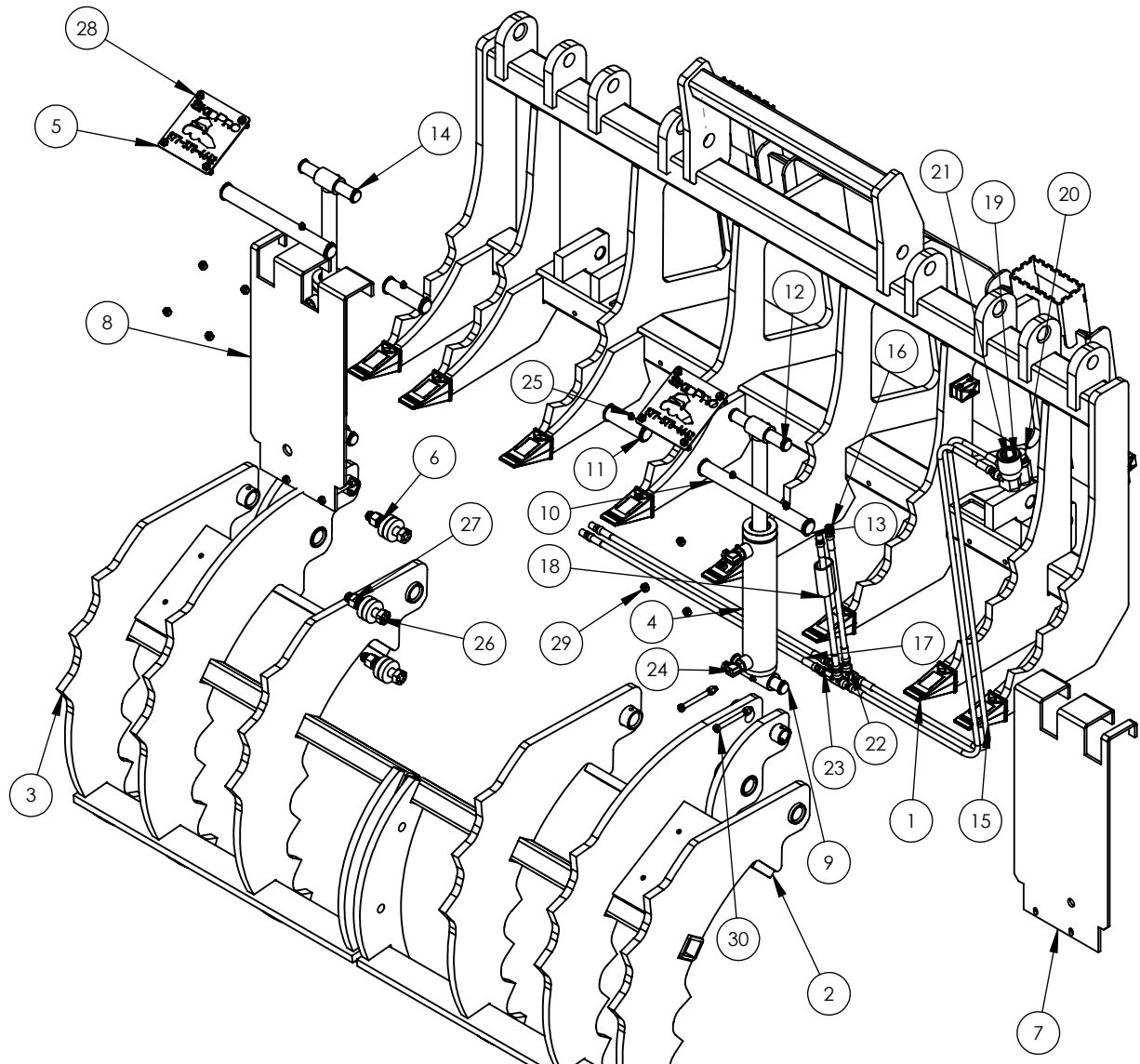

TORQUE SPECIFICATION TABLE

General Specification Table

Use the following torques when special torques are not given. Note: These values apply to fasteners as received from supplier, when dry. These values do not apply if lubricants are used.

BOLT SIZES (SAE)	TORQUE	
INCHES	POUNDS-FOOT (NC Threads) Grade 5 / Grade 8	POUNDS-FOOT (NF Threads) Grade 5 / Grade 8
1/4	7/11	9/13
5/16	15/22	17/24
3/8	30/40	35/45
7/16	45/65	50/70
1/2	70/95	75/110
9/16	100/140	110/155
5/8	135/190	155/215
3/4	240/340	270/380
7/8	360/550	390/610
1	530/820	590/890
1 1/8	800/1440	880/1500
1 1/4	1240/2000	1364/2200
1 3/8	1680/2720	1848/2800
1 1/2	2200/3500	2420/3600

BOLT SIZES (METRIC)	TORQUE	
MILLIMETERS	POUNDS-FOOT	NEWTONS-METER
M6	10	13
M8	22	30
M10	40	54
M12	59	80
M14	93	126
M16	130	176
M18	168	228
M20	205	278



PO Box 982, 807 McKay Ave S.
Alexandria, MN 56308
Toll Free: 877-378-4642
www.skidpro.com

SKID PRO WARRANTY

Skid Pro warrants above attachments for twenty-four months from date of shipment to the original owner. Warranty covers products to be free from defects in material and workmanship when properly set up and operated in accordance with Skid Pro's recommendations.

WARRANTY CLAIM PROCEDURE

All warranty claims must be submitted within the manufacturer's limited warranty period. Pictures and/or a video as well as a detailed description of the events leading up to the failed component(s) are required to properly document all potential warranty claims. To submit a warranty claim, contact your Skid Pro Product Guru or complete a [Warranty Claim Form](#) on our website and send it along with supporting pictures/video to sales@skidpro.com. A valid credit card is required to be on file with Skid Pro to begin processing a warranty claim. No warranty claim will be processed without a valid credit card on file. Upon receipt, the warranty claim information will be reviewed and once determined to be a valid claim, a return authorization number will be issued for the return of the defective part(s) if applicable and replacement part(s) will be shipped. If it is determined the defective parts are to be returned and they are not received by Skid Pro within 30 days of receiving the replacement parts, the buyer's credit card on file will be charged for the cost of the replacement parts plus any shipping charges. Tampering with the failed part (i.e. disassembling a motor or cylinder) will void the warranty.

EXCLUSIONS OF WARRANTY

Skid Pro's requirement for any issue with respect to attachments shall be limited to repairing or replacing the defective part, as this is a parts-only warranty and does not include labor to replace or install the part, interest accrued or payments made for financing, or downtime from resulting issue. Skid Pro has full technical support to assure customer replaces the part properly.

This warranty shall not apply to any attachment's wear items, or attachments that have been repaired or altered outside the Skid Pro factory in any way, or that has been subject to misuse, negligence, or accident beyond Skid Pro's recommended use and/or machine rated capacity.

This warranty is exclusive and in lieu of all other warranties and conditions. Skid Pro disclaims all other warranties and conditions, express or implied, including any implied warranties or conditions of merchantability or fitness for a particular purpose. In no event shall Skid Pro be liable for any special, incidental, indirect or consequential damage, whatsoever, including, but not limited to, loss or interruption of business, lost profits, or loss of machine use, whether based on contract, warranty, tort, negligence, strict liability, statute or otherwise, even if Skid Pro has been advised of the possibility of such damages.

Hoses and couplers are tested on the attachment prior to shipment and are excluded from the warranty. It is the responsibility of the operator to ensure adequate clearance and hose routing as each carrier machine differs and improper routing can lead to hose damage and premature failure. If hose length is an issue due to the style or type of carrier machine, it is the responsibility of the end user to source correctly sized hoses as they are outside of the normal distribution of carrier machines within the industry.

No agent, employee, or representative of Skid Pro has any authority to bind said company to any affirmation, representation, or warranty concerning its machinery and/or attachments except as specifically set forth herein. Any disagreement or dispute of warranty policy or customer expectations of product, soundness, functionality, or performance would take place in Douglas County, Alexandria, MN, where Skid Pro operates.



**PO BOX 982
Alexandria, MN 56308**

**Phone: 877-378-4642
FAX: 320-759-1057
www.skidpro.com
sales@skidpro.com**