

Standard Flow Closed Front Serial Number 02934 to 03091
Standard Flow Open Front Serial Number 41845 to 42231
High Flow Closed Front Serial Number 11717 and 11719 to 11720
High Flow Open Front Serial Number 11718, 41798 and 032516 to 032567

PARTS DIAGRAMS AND LISTS

Brush Cutter - Diagram A

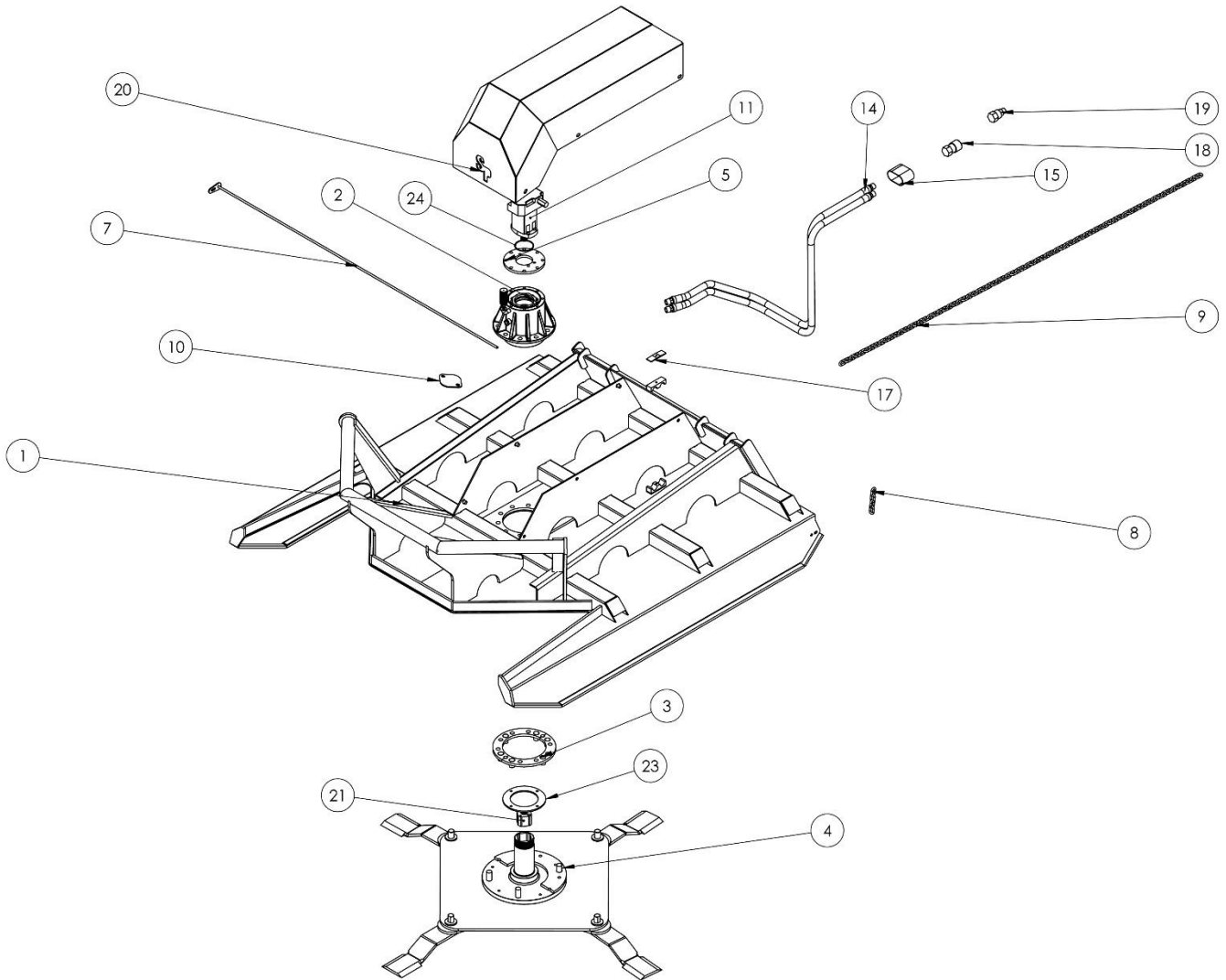

Brush Cutter - Parts List A

ITEM NO.	PART NUMBER	DESCRIPTION	QTY.
1	612-2-0020-2	Mower Body, Open Front	1
2	612-2-0005-2	Bearing Housing, Assembled	1
3	612-2-0008-2	Wire Protection, Upper	2
4	612-2-0012-2	Flywheel Assembly	1
5	612-3-0111-20	Motor Mount Plate, Standard Flow	1
5	612-3-0111	Motor Mount Plate, High Flow	1
7	612-2-0011	Chain Rod	1
8	612-3-0045	Debris Chain	46
9	612-3-0046	Safety Chain	1
10	612-3-0025	Inspection Cover	1
11	612-3-0060 Eaton	Motor, Standard Flow	1
11	612-3-0060HF1	Motor Assembly, High Flow	1
13	902-09001A	Hose Clamp Tab	1
14	612-2-0013	Hose Assembly	2
17	612-3-0069	Hose Clamp Bolt Plate	1
18	612-3-0070	Female Quick Coupler	1
19	612-3-0071	Male Quick Coupler	1
20	612-3-0027-2	Motor Cover	1
21	612-3-0110-20	Hub, Standard Flow	1
21	612-3-0110	Hub, High Flow	1
23	612-3-0063-2	Seal Protection	1
24	612-3-0132	O-Ring, Standard Flow	1
25	612-3-0134	O-Ring, High Flow	1

Drive Assembly - Diagram B

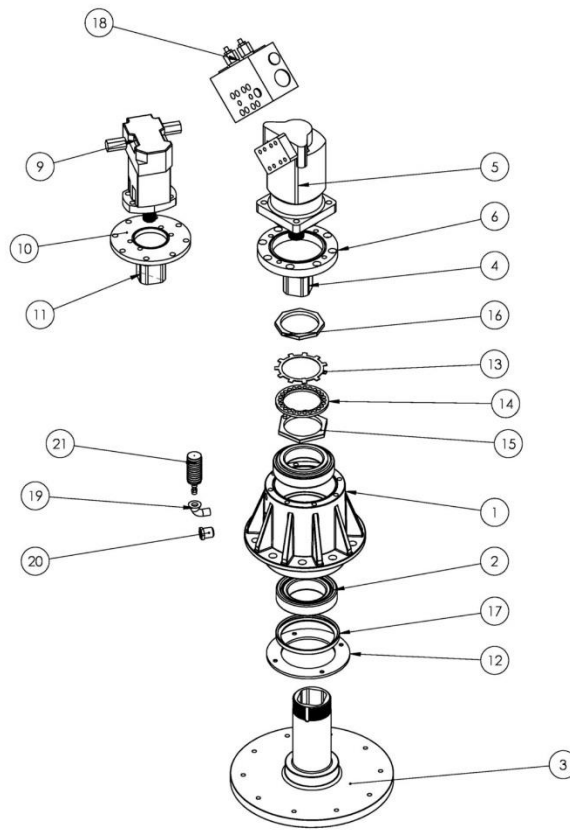

Drive Assembly - Parts List B

ITEM NO.	PART NUMBER	DESCRIPTION	QTY.
1	612-2-0024	Bearing Housing	1
2	612-2-0030	3.750 Bearing & Race	2
3	612-2-0025	Shaft	1
4	612-3-0110	Hub, High Flow	1
5	612-3-0060-HF	Motor Assembly, High Flow	1
6	612-3-0111	Motor Mounting Plate, High Flow	1
9	612-3-0060 Eaton	Motor, Standard Flow	1
10	612-3-0111-20	Motor Mounting Plate, Standard Flow	1
11	612-3-0110-20	Hub, Standard Flow	1
12	612-3-0063-2	Seal Protection	1
13	612-3-0051-2	Jam Nut Retainer	1
14	612-3-0050-2	Lock Nut Retainer	1
15	612-3-0096-2	Lock Nut	1
16	612-3-0095-2	Jam Nut	1
17	RTD-52625TA-H	Seal	1
18	AU-02-2052	Relief Manifold Assembly (High Flow Only)	1
19	612-3-0057	3/8" NPT ST 90	1
20	612-3-0055	Sight Glass	1
21	612-3-0056	Expansion Bellows	1

Bearing Housing Assembly - Diagram C

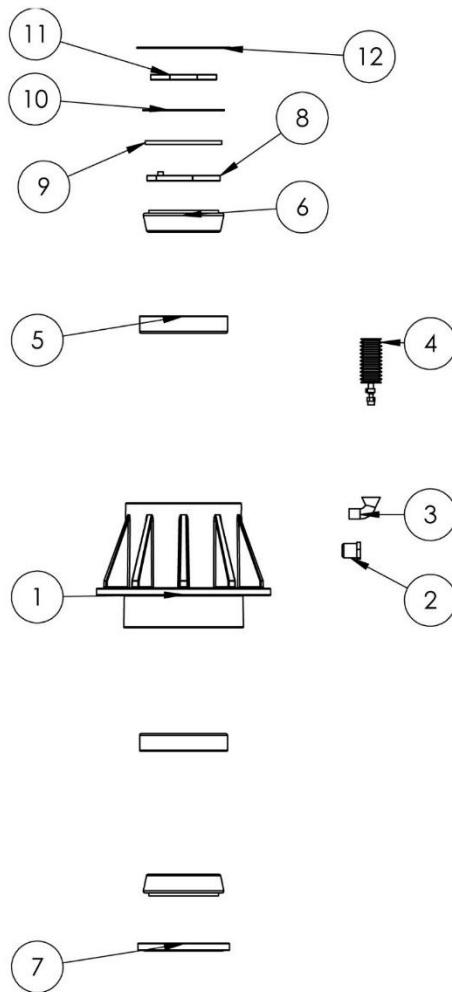

Bearing Housing Assembly - Parts List C

ITEM NO.	PART NUMBER	DESCRIPTION	QTY.
1	612-2-0024	Bearing Housing	1
2	612-3-0055	Sight Glass	1
3	612-3-0057	3/8" NPT ST 90	1
4	612-3-0056	Expansion Bellows	1
5	612-3-0053-2	Bearing Race	2
6	612-3-0054-2	Bearing	2
7	RTD-52625TA-H	Seal	1
8	612-3-0096-2	Lock Nut	1
9	612-3-0050-2	Lock Nut Retainer	1
10	612-3-0051-2	Jam Nut Retainer	1
11	612-3-0095-2	Jam Nut	1
12	612-3-0133	O-Ring	1

Flywheel Assembly - Diagram D

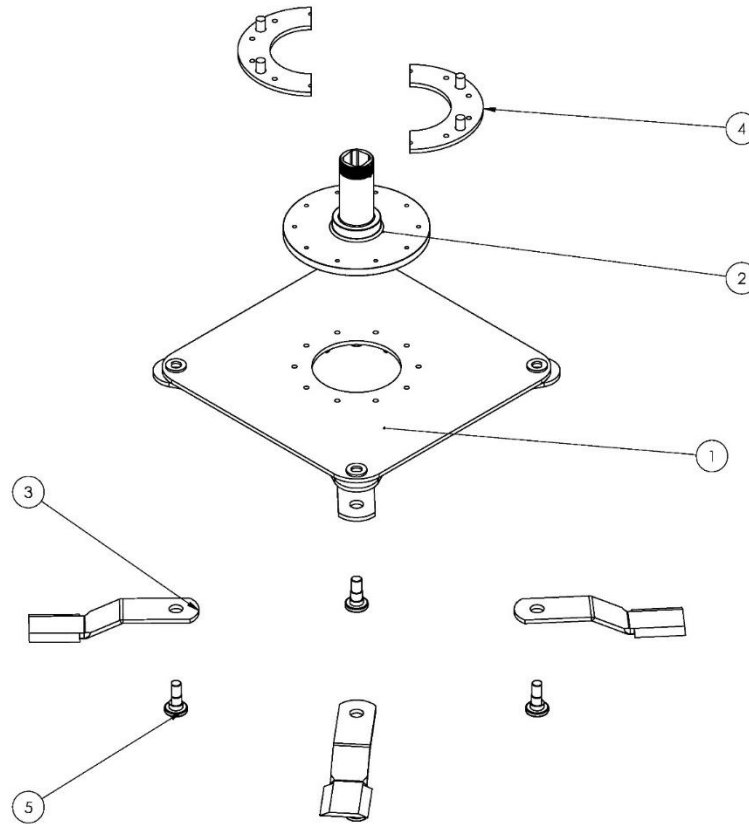

Flywheel Assembly - Parts List D

ITEM NO.	PART NUMBER	DESCRIPTION	QTY.
1	612-2-0004	Flywheel Plate	1
2	612-2-0025	Drive Shaft	1
3	612-3-0013	Blade	4
4	612-2-0007-2	Wire Protection, Lower	2
5	612-3-0048	Blade Bolt	4

Warning Decal Placement – Diagram E

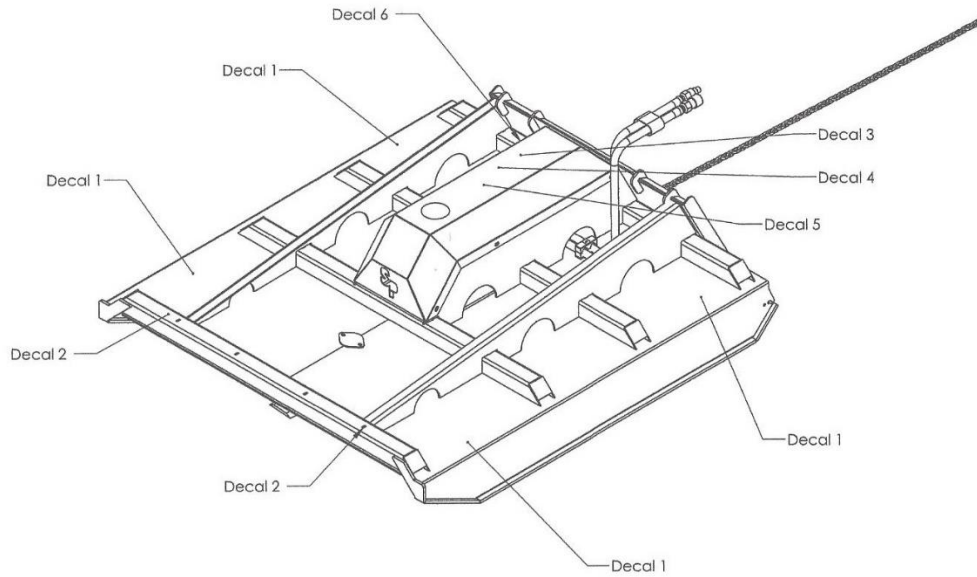

Figure 1 - Brush Cutter - Rear View

Warning Decals - Parts List E

ITEM #	PART NAME	DESCRIPTION	QTY.
1	Warning Decal	Warning Keep Hands and Feet Away	4
2	Warning Decal	DANGER Debris Discharge Area Stay Back 200 Feet	2
3	Warning Decal	Do Not Operate Without Safety Chain In Place	1
4	Warning Decal	High Pressure Fluid Hazard	1
5	Warning Decal	Read Owner's Manual Before Operating	1
6	Identification Decal	Model #/Serial #	1

Warning Decal Graphics



Decal 1



Decal 2



Decal 3



Decal 4

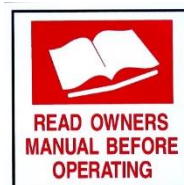

Decal 5



Decal 6