



## 4N1 Bucket

# Operation and Maintenance Manual



Revision Date: March 2024

**Skid Pro**  
PO Box 982  
Alexandria, MN 56308  
Toll Free: 877-378-4642

[www.skidpro.com](http://www.skidpro.com)

## TABLE OF CONTENTS

<b>INTRODUCTION</b> .....	<b>2</b>
To the Purchaser .....	2
Illustrations.....	2
Direction Reference .....	2
<b>SAFETY PRECAUTIONS</b> .....	<b>3</b>
Before Operation.....	3
Children.....	3
Notice.....	4
Safety Precautions – 4N1 Bucket .....	4
<b>4N1 BUCKET OPERATION</b> .....	<b>5</b>
<b>THE SKID STEER</b> .....	<b>6</b>
General Information .....	6
Operating the Skid Steer.....	6
During Operation.....	7
Roll-Over Protective Structure (ROPS) During Operation.....	7
<b>MAINTENANCE</b> .....	<b>8</b>
<b>TRANSPORTING</b> .....	<b>9</b>
<b>STORAGE</b> .....	<b>9</b>
<b>OPERATION</b> .....	<b>10</b>
General Preparation.....	10
Engine Speed .....	10
Engaging the Drive Mechanism .....	10
<b>4N1 BUCKET PARTS</b> .....	<b>10</b>
Introduction .....	10
4N1 Bucket Assembly – Detailed Parts Diagram A.....	11
4N1 Bucket Assembly - Parts List A.....	11
<b>SKID PRO ATTACHMENT WARRANTY</b> .....	<b>12</b>

# INTRODUCTION

## To the Purchaser

All products are designed to give safe, dependable service if they are operated and maintained per instructions. Read and understand this manual before operation.

This manual has been prepared to assist the owner and operators in the safe operation and suitable maintenance of the equipment. The information was applicable to products at the time of manufacture and does not include modifications made afterwards.

Read and understand this operator's manual before attempting to put equipment into service. Familiarize yourself with the operating instructions and all the safety recommendations contained in this manual and those labeled on the equipment and on the skid steer. Follow the safety recommendations and make sure that those with whom you work follow them.

## Illustrations

The illustrations may not necessarily reproduce the full detail and the exact shape of the parts or depict the actual models, but are intended for reference only.

## Direction Reference

All references to right and left, forward or rearward, are from the operator's seat, facing the steering wheel.

To assist your dealer in handling your needs, please record hereafter the model number and the serial number of your equipment and skid steer. It is also advisable to supply them to your insurance company. It will be helpful in the event that an equipment or skid steer is lost or stolen.

### SKID STEER

### IMPLEMENT

MODEL: \_\_\_\_\_

SERIAL NUMBER: \_\_\_\_\_

DATE OF PURCHASE: \_\_\_\_\_

DEALER NAME: \_\_\_\_\_

## SAFETY PRECAUTIONS



### SAFETY FIRST

This symbol, the industry's "Safety Alert Symbol", is used throughout this manual and on labels on the machine itself to warn of the possibility of personal injury. Read these instructions carefully. It is essential that you read the instructions and safety regulations before you attempt to assemble or use this unit.



**DANGER:** Indicates an immediate hazardous situation which, if not avoided, will result in death or serious injury.



**WARNING:** Indicates a potentially hazardous situation which, if not avoided, will result in death or serious injury.



**CAUTION:** Indicates a potentially hazardous situation which, if not avoided, may result in minor or moderate injury.

**IMPORTANT:** Indicates that equipment or property damage could result if instructions are not followed.

**NOTE:** Gives helpful information.

All products are designed to give safe, dependable service if they are operated and maintained according to instructions. **Read and understand this manual before operation.** It is the owner's responsibility to be certain anyone operating this product reads this manual, and all other applicable manuals to become familiar with this equipment and all safety precautions. Failure to do so could result in serious personal injury or equipment damage. If you have any questions, consult your dealer.

### Before Operation

#### Children

Tragic accidents can occur if the operator is not alert to the presence of children. Children are generally attracted to machines and work being done. Never assume children will remain where you last saw them.

1. Keep children out of the operating area and under the watchful eye of another responsible adult.
2. Be alert and turn machine off if children enter the work area.
3. Before and when backing, look behind for small children, use care when approaching blind corners.
4. Never carry children while operating the machine. They may fall off and be seriously injured or interfere with the safe operation of the machine.
5. Never allow children to play on the machine or attachment even when they are turned off.
6. Never allow children to operate the machine even under adult supervision.

## **Notice**

A safe operator is the best assurance against accidents. All operators, no matter how experienced they may be, should read this operator's manual and all other related manuals before attempting to operate the equipment. Please read the following section and pay particular attention to all safety recommendations contained in this manual and those labeled on the equipment and on the skid steer.

## **Safety Precautions – 4N1 Bucket**

1. Read and understand this operator's manual and skid steer operator's manual. Know how to operate all controls and how to stop the unit and disengage the controls quickly.
2. Never wear loose, torn, or bulky clothing around the skid steer and the bucket. It may catch on moving parts or controls, causing injury.
3. Before and during use, thoroughly inspect the area where the equipment is to be used and remove all objects that may cause damage to the equipment.
4. Set transmission to neutral and disengage clutch, if equipped, before starting the engine.
5. Do not operate equipment without protective clothing.
6. Never attempt to make any adjustments while engine is running. Read this manual carefully to acquaint yourself with the equipment as well as the skid steer operator's manual. Working with unfamiliar equipment can lead to accidents. Be thoroughly familiar with the controls and proper use of the equipment.
7. Keep all safety guards in place and verify hardware for proper tightening.
8. Check for moving parts excessive wear regularly. Replace worn parts with genuine parts.
9. Replace all missing, illegible, or damaged safety and warning decals. See list of decals in operator's manual.
10. Keep safety decals clean of dirt and grime.
11. Do not modify or alter this equipment or any of its components, any equipment or any of its components or any equipment function without first consulting your dealer.
12. Use of counterweights is recommended. Weights provide the necessary balance to improve stability, traction and steering. Use only those recommended by your dealer.

## 4N1 BUCKET OPERATION

1. Before leaving the skid steer unattended, take all possible precautions. Park the skid steer/4N1 bucket on level ground, place the transmission in neutral, set the parking brake, disengage the Aux hydraulics, lower the equipment to the ground, place all levers including auxiliary control levers in neutral, shut off the engine and remove the ignition key.
2. Prior to operation mark all curbs, pipes, etc. that cannot be moved.
3. Be sure the Aux hydraulics switch/lever is in OFF position before starting engine.
4. Exercise extreme caution when operating on or crossing a gravel drive, walks, or roads. Stay alert for hidden hazards or traffic.
5. Do not carry passengers.
6. Keep clear of moving parts.
7. Park the skid steer/4N1 bucket on level ground, place the transmission in neutral, set the parking brake, disengage the Aux hydraulics, lower the equipment to the ground, place all control levers in neutral, shut off the engine, remove the ignition key and allow the moving parts to stop BEFORE and making any repairs, adjustments or inspections.
8. If the 4N1 bucket starts to vibrate abnormally, disengage the Aux hydraulics, stop the engine immediately and check for cause. Excessive vibration is generally a sign of trouble.
9. Do not run the engine indoors except when starting engine and transporting attachment in or out of building. Carbon monoxide gas is colorless, odorless and deadly.
10. Do not attempt to operate on steep slopes. If operating on slopes is necessary, exercise extreme caution when changing direction.
11. Never operate 4N1 bucket without safety protective devices in place.
12. Never operate machine at high transport speeds on a slippery surface.
13. Use extra caution when backing up.
14. Never operate the 4N1 bucket without good visibility and lighting.
15. Prolonged exposure to loud noise can cause impairment or loss of hearing. Wear a suitable hearing device such as earmuffs or earplugs to protect against objectionable or uncomfortable noises.
16. Never allow anyone near the work area.

# THE SKID STEER

## General Information

1. Read the operator's manual carefully before using skid steer. Lack of operating knowledge can lead to accidents.
2. Do not permit anyone but the operator to ride on the skid steer. There is no safe place for passengers.

## Operating the Skid Steer

1. Never run the skid steer engine in a closed building without adequate ventilation, as the exhaust fumes are very dangerous.
2. Adopt safe driving practice: Keep the parking brake on at all times during transportation.
3. Always drive at a safe speed relative to local conditions and ensure that your speed is low enough for an emergency stop to be safe and secure.
4. Reduce speed prior to turns to avoid the risk of overturning. Keep speed to a minimum.
5. Always keep the skid steer in gear to provide engine braking when going downhill. Do not coast.
6. Never allow an open flame near the fuel tank or battery.
7. Make sure the proper shields are installed when using the equipment and always replace the shields if damaged.
8. Park the skid steer/4N1 bucket on level ground, place the transmission in neutral, set the parking brake, disengage the Aux hydraulics, lower the equipment to the ground, place all levers including auxiliary control levers in neutral, shut off the engine and remove the ignition key BEFORE leaving the skid steer.
9. Never park or operate the skid steer on a steep slope. Avoid sudden uphill turns on steep slopes.
10. Use of counterweights for better traction and stability is recommended.
11. Handle fuel with care, as it is highly flammable.
12. Use approved fuel container, never add fuel to running engine or a hot engine.
13. Fill fuel tank outdoors with extreme care. Never fill fuel tank indoors. Replace fuel cap securely and wipe up spilled fuel.
14. Never allow anyone to operate the 4N1 bucket until they have read the manual completely and are thoroughly familiar with basic skid steer and 4N1 bucket operation.
15. Make sure the skid steer is counterweighted as recommended by your dealer. Weights provide the necessary balance to improve stability, traction and steering.
16. Always make sure all 4N1 bucket components are properly installed and securely fastened BEFORE operation.
17. Always start the engine from the operator's seat with all the transmission lever(s) and 4N1 bucket drive lever (if applicable) in neutral.
18. DO NOT bypass the safety system by shorting across the terminals of the starter motor to start the engine. This may cause the skid steer to move suddenly.
19. If the safety start system does not work, consult your dealer immediately.

## **During Operation**

1. Do not allow passengers on the skid steer/4N1 bucket at any time. There is no safe place for passengers on the equipment. The operator **MUST** sit in the skid steer seat.
2. Eye and hearing protection is recommended when operating the 4N1 bucket.
3. Operate only during daylight hours, or when the area is well lit with bright artificial light.
4. Park the skid steer/4N1 bucket on level ground, place the transmission in neutral, set the parking brake, disengage the Aux hydraulics, lower the equipment to the ground, place all control levers in neutral, shut off the engine and remove the ignition key **BEFORE** leaving the operator's seat.
5. Inspect the 4N1 bucket after striking any foreign object to assure that all 4N1 bucket parts are safe and secure and not damaged.
6. Be especially observant of the operating area and terrain. Watch for holes, rocks, or other hidden hazards. **ALWAYS** inspect the area prior to using the 4N1 bucket.
7. **DO NOT** use the 4N1 bucket near the edge of drop-offs or banks.
8. **DO NOT** use the 4N1 bucket on steep slopes as overturn may result.
9. Operate up and down (not across) intermediate slopes. Avoid sudden starts and stops.
10. Drive skid steer backwards up steeper slopes.
11. Slow down before you change directions on any slope.
12. Use wheel weights on your skid steer to increase stability on slopes.
13. Never stand alongside of the unit while the engine is running.

## **Roll-Over Protective Structure (ROPS) During Operation**

1. **DO NOT** weld, drill or alter the ROPS. Damaged ROPS must not be straightened or used. If damage does occur, consult your dealer.
2. If ROPS is lowered or removed from the skid steer for any reason, it must be erected and/or refitted immediately. Original bolts or equivalent replacements must be used and tightened to the correct torque.
3. Your dealer does not recommend usage of skid steer with ROPS removed.
4. Seat belt usage: With ROPS installed on the skid steer it is imperative that the seat belt be installed, used and correctly adjusted, at all times. **DO NOT** use a seat belt if operating without ROPS.
5. Keep all shields and covers in place. All skid steer and equipment shields and covers must be correctly installed at all times. When necessary to remove these, they must be reinstalled immediately.
6. Keep clear of all rotating driveline components. Be especially observant of implement areas of discharge, intake or other mechanical motion.
7. Securely lock equipment drive shaft. Check that all skid steer and equipment drivelines are in good working order.
8. Additional safety equipment: A fire extinguisher and first aid kit should be kept readily accessible.



## MAINTENANCE

***Always use genuine parts when replacement parts are required during operation.***

1. Keep the skid steer and 4N1 bucket properly maintained.
2. Park the skid steer/4N1 bucket on level ground, place the transmission in neutral, set the parking brake, disengage the Aux hydraulics, lower the equipment to the ground, place all control levers in neutral, shut off the engine and remove the ignition key and allow the rotating parts to stop BEFORE making any 4N1 bucket adjustments.
3. To avoid injury, do not adjust or service the 4N1 bucket with the skid steer engine running. Make sure moving components have completely stopped before leaving the operator's seat.
4. Keep the skid steer/4N1 bucket clean.
5. Always wear eye protection when cleaning or servicing the 4N1 bucket.
6. Service the unit in safety: DO NOT service the skid steer while the engine is running or hot, or if the unit is in motion. Always lower 4N1 bucket to the ground. If necessary to service unit with 4N1 bucket raised, securely support with stands or suitable blocking before working underneath. Do not rely on hydraulically supported devices for your safety. They can settle suddenly, leak down, or be accidentally lowered.
7. Do not attempt to service machine, clear obstructions or unplug blockages with the engine running. Always shut off engine and allow all motion to cease.
8. The manufacturer will not claim responsibility for fitment of unapproved parts and/or accessories and any damages as a result of their use.
9. Make sure all shields and guards are securely in place following all service, cleaning, or repair work.
10. Do not modify or alter this equipment or any of its components or operating functions. If you have any questions concerning modifications, consult with your dealer.
11. Do not operate a unit which is defective or has missing parts. Make sure that all recommended maintenance procedures are completed before operating the unit.
12. Check all controls regularly and adjust where necessary.
13. Periodically check all nuts and bolts for tightness, especially wheel hub and rim nuts. Make sure all non-rotating pins are secured properly.
14. Check hydraulic cylinders and hoses for damage or leaks. To avoid serious personal injury: Escaping hydraulic/diesel fluid under pressure can penetrate the skin causing serious injuries. Do not use your hands to check for leaks. Use a piece of cardboard or paper to search for leaks.
15. Stop engine and relieve pressure before connecting lines. Tighten all connections before starting engine or pressurizing lines.

## TRANSPORTING

1. Transporting on public roadway: When driving the skid steer and equipment on the road or highway under 25 mph, at night or during the day, use flashing amber warning lights and the Slow Moving Vehicle ("SMV") identification emblem.
2. Check local traffic codes that may apply to unit usage on public roads and highways in your area. The use of flashing amber lights is acceptable in most localities. However, some localities may prohibit their use.
3. Always disengage equipment drive prior to transporting unit.

## STORAGE

***Before storing the 4N1 bucket, certain precautions should be taken to protect it from deterioration.***

1. Clean the 4N1 bucket throughout.
2. Make all the necessary repairs.
3. Replace all safety signs that are damaged, lost, or otherwise become illegible. If a part to be replaced has a sign on it, obtain a new safety sign from your dealer and install it in the same place as on the removed part.
4. Repaint all parts from which paint has worn or peeled.
5. When the 4N1 bucket is dry, oil all moving parts. Apply oil liberally to all surfaces to protect against rust.
6. Store in a dry place

# OPERATION

## General Preparation

1. Read the operator's manual carefully before using the skid steer and 4N1 bucket. Be thoroughly familiar with the controls and proper use of the equipment. Know how to stop the unit and disengage the controls quickly.
2. Wear appropriate outer garments while operating the equipment.
3. Make sure the bucket can operate freely.
4. Before engaging the 4N1 bucket, always have the engine running at idle.

## Engine Speed

1. Start the skid steer engine. Let the engine warm up at least one minute before engaging the drive mechanism then increase speed gradually.
2. Make sure the 4N1 bucket is properly positioned and engage the drive mechanism.
3. Adjust the ground speed according to conditions.

## Engaging the Drive Mechanism

Refer to the skid steer's operating manual for instructions.

# 4N1 BUCKET PARTS

## Introduction

All parts are illustrated in "exploded views" which show the individual parts in the normal relationship to each other. Reference numbers are used in the illustrations. These numbers correspond to those in the "*Item No.*" column, and are followed by the description and quantity required.

The manufacturer reserves the right to change, modify, or eliminate from time to time, for technical or other reasons, certain or all data, specifications, or the product or products themselves, without any liability or obligation.

ITEM NO.	PART NUMBER	DESCRIPTION	QTY.
1	657-02-0010	2.5 X 10 CYLINDER	2
2	777-02-0001-XX	4-N-1 BUCKET - BODY	1
3	777-02-0002-XX	4-N-1 BUCKET - MOUNT	1
4	777-02-0004	4N1 BUCKET HOSE	2
5	777-02-0027	4N1 BUCKET HOSE	2
6	777-02-0028	4N1 BUCKET HOSE	2
7	777-03-0018	CYLINDER PIN (TOP)	2
8	777-03-0019	PIVOT PIN	2
9	777-03-0020	CYLINDER PIN (BOTTOM)	2
10	AU-03-0625-XX	SINGLE BOLT ON CUT EDGE	1
11	AU-03-9990-12-12	1/2" FEMALE COUPLER	1
12	AU-03-9991-12-12	1/2" MALE COUPLER	1
13	H250-6MJICTEE	6MJIC UNION TEE	2
14	H250-FT2062-8-6S	8 MORB X 6 MJIC 90°	4
15	H375-FT21-6-12	-12 MORB TO -6 MJIC	2
16	HSL250	.250" HOSE SLEEVE	1
17	HW-.125-NPTS GF	.125 STRAIGHT GREASE ZERK	2
18	HW-.25-20 NYL	1/4"-20 NYLOCK NUT	4
19	HW-.25-20X2.0 G5	1/4 X 2.00 BOLT	4
20	HW-.375-16 NYL	3/8 - 16 NYLOCK NUT	2
21	HW-.375-16X2.5 G5	3/8-16 X 2.50 GRADE 5 BOLT	2
22	HW-.625-11 NYL G5	5/8"-11 NYLOCK NUT G5	10
23	HW-.625-11X2.0 PB	5/8"-11 X 2" PLOW BOLT	10

\*PART NUMBERS WITH XX INDICATE VARIENCE IN WIDTH ITEMS.

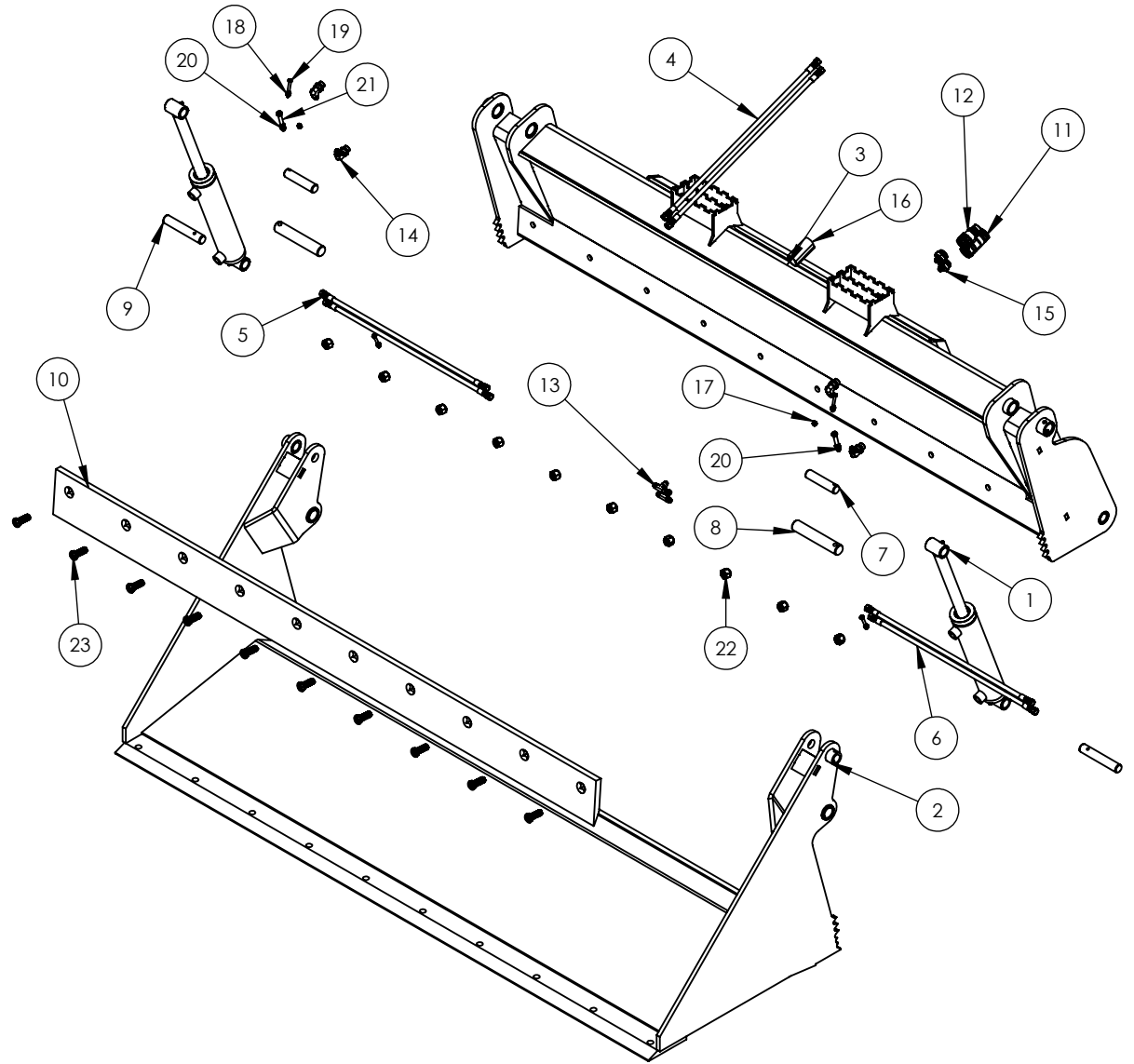

## SKID PRO ATTACHMENT WARRANTY

Attachments covered under this 12 Month Warranty include:

**Buckets: 4N1, Concrete, Low Profile, Mega Snow, Snow & Litter, Stump & Rock; Grapples: Bucket, Skeleton, Scrap, Tine & Extra Heavy-Duty Rock Bucket; HD3 Brush Mower; Log Splitter; Pallet Fork Grapple; Hydraulic Pallet Forks; Snow Pusher; Telescopic Boom; Tree Puller; Bale Squeeze; Silt Fence Plow; Over the Tire Tracks; Trencher; Pick Up Broom; U-Blade; Trencher; Vibratory Roller;**

Skid Pro warrants above attachments for twelve months from date of shipment, to the original owner. Warranty covers products to be free from defects in material and workmanship when properly set up and operated in accordance with Skid Pro's recommendations.

### WARRANTY CLAIM PROCEDURE

All warranty claims must be submitted within the manufacturer's limited warranty period. Pictures and/or a video of the failing component(s) are required to properly document all potential warranty claims. To submit a warranty claim, contact your Skid Pro Product Guru or complete a [Warranty Claim Form](#) on our website and send it along with supporting pictures/video to [sales@skidpro.com](mailto:sales@skidpro.com). Upon receipt, the warranty claim information will be reviewed and once determined to be a valid claim, a return authorization number will be issued for the return of the defective part(s) if applicable and replacement part(s) will be shipped. If it is determined the defective parts are to be returned and they are not received by Skid Pro within 30 days of receiving the replacement parts, the Buyer will be charged for the cost of the replacement parts plus any shipping charges. Tampering with the failed part (i.e. disassembling a motor or cylinder) will void the warranty.

### EXCLUSIONS OF WARRANTY

Skid Pro's requirement for any issue with respect to attachments shall be limited to repairing or replacing the defective part, as this is a parts-only warranty and does not include any labor to replace or install the part or downtime from resulting issue. Skid Pro has full technical support & assistance to assure customer replaces the part properly for optimal performance on attachment.

This warranty shall not apply to any attachment's wear items, or attachments that have been repaired or altered outside the Skid Pro factory in any way, or that has been subject to misuse, negligence or accident beyond Skid Pro's recommended use and/or machine rated capacity.

This warranty is exclusive and in lieu of all other warranties and conditions. Skid Pro disclaims all other warranties and conditions, express or implied, including any implied warranties or conditions of merchantability or fitness for a particular purpose. In no event shall Skid Pro be liable for any special, incidental, indirect or consequential damage, whatsoever, including, but not limited to, loss or interruption of business, lost profits, or loss of machine use, whether based on contract, warranty, tort, negligence, strict liability, statute or otherwise, even if Skid Pro has been advised of the possibility of such damages.

No agent, employee, or representative of Skid Pro has any authority to bind said company to any affirmation, representation, or warranty concerning its machinery and/or attachments except as specifically set forth herein. Any disagreement or dispute of warranty policy or customer expectations of product, soundness, functionality, or performance would take place in Douglas County, Alexandria, MN, where Skid Pro operates.



**PO BOX 982  
Alexandria, MN 56308**

**Phone: 877-378-4642  
FAX: 320-759-1057  
[www.skidpro.com](http://www.skidpro.com)  
[sales@skidpro.com](mailto:sales@skidpro.com)**